

4

3

2

1

V1K Part Number	Max Voltage	Amps	Phase	Weight (LBS)
V1K80A00*	600	80	3	23
V1K80A00EX*	600	80	3	23

* = (Blank) - No Thermal Switch
 * = T - Thermal Switch Option

See V1K Installation Guide For Terminal Wire Size And Torque Information.

Note: Maintain Clearance of 3 Inches On All Sides To Other Equipment.

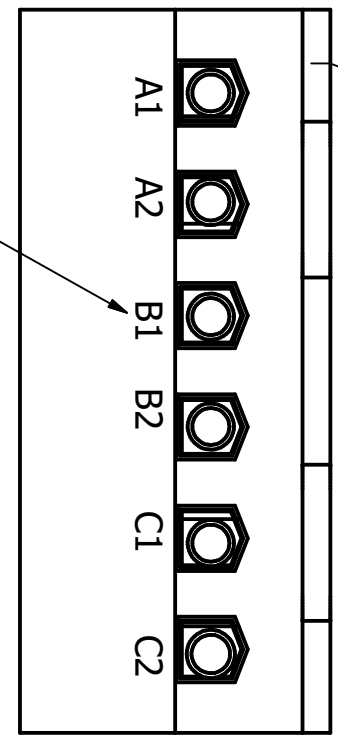
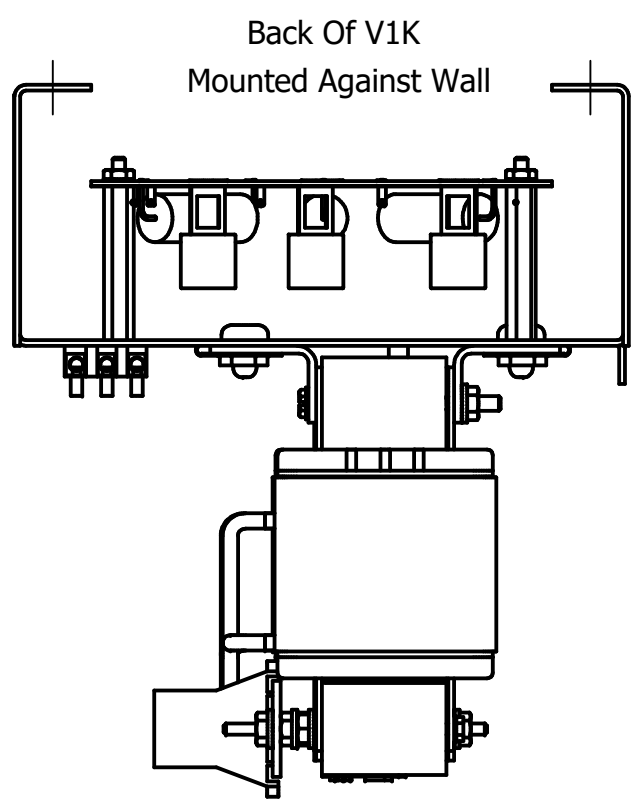
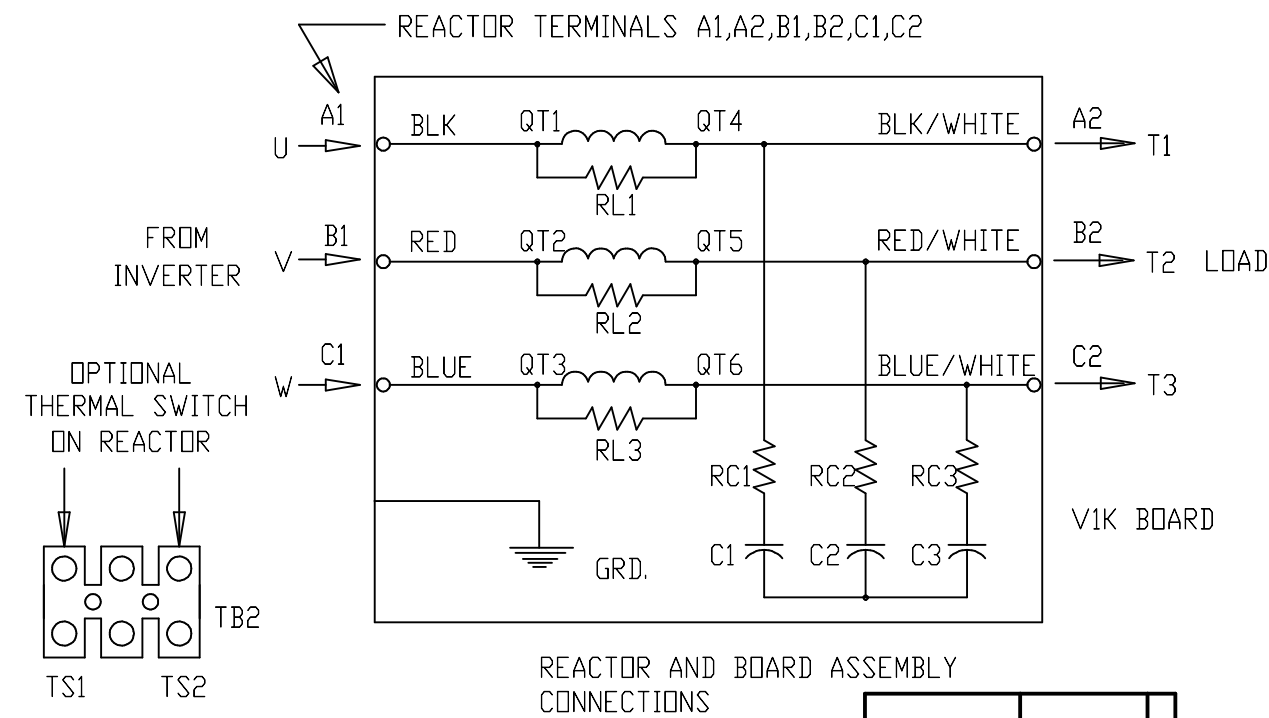

(Customer Connections) Markings On Terminal Block For Reference Only.

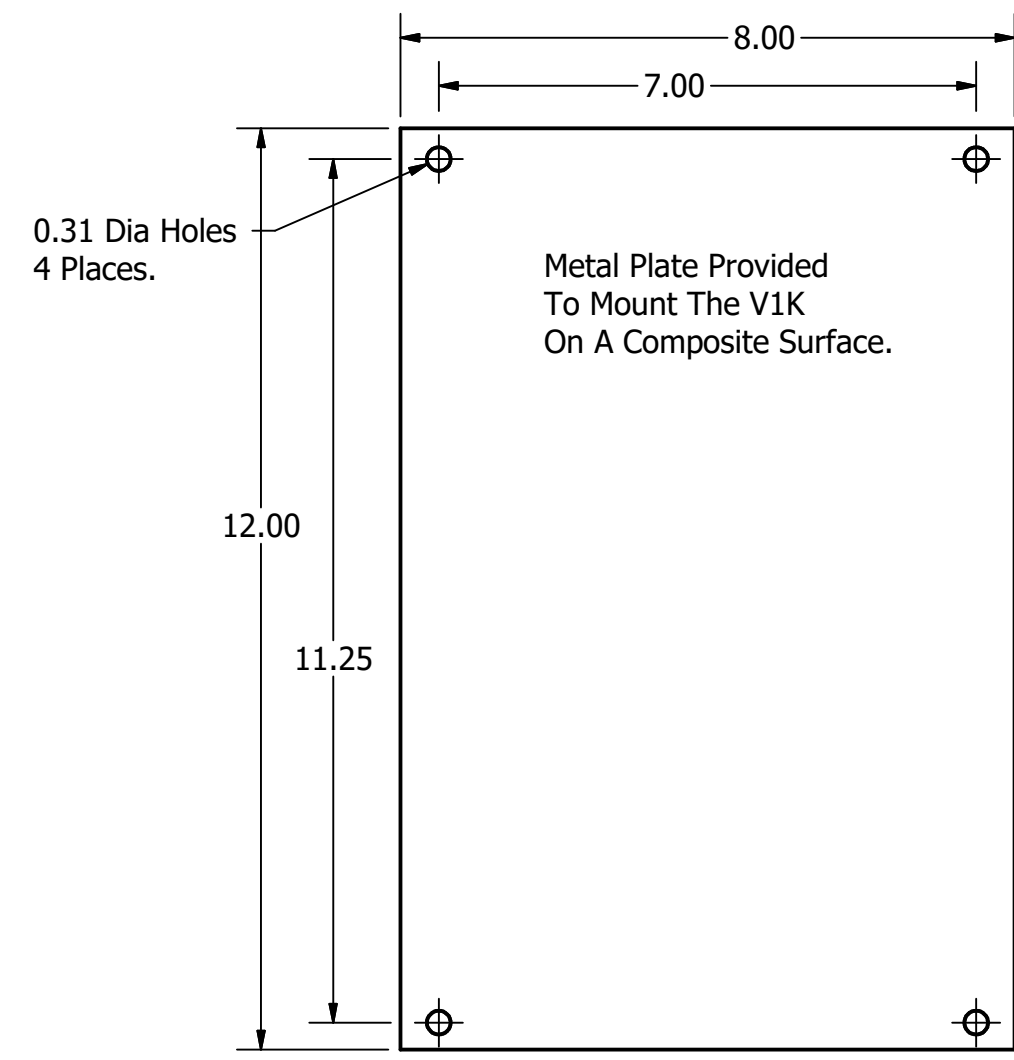
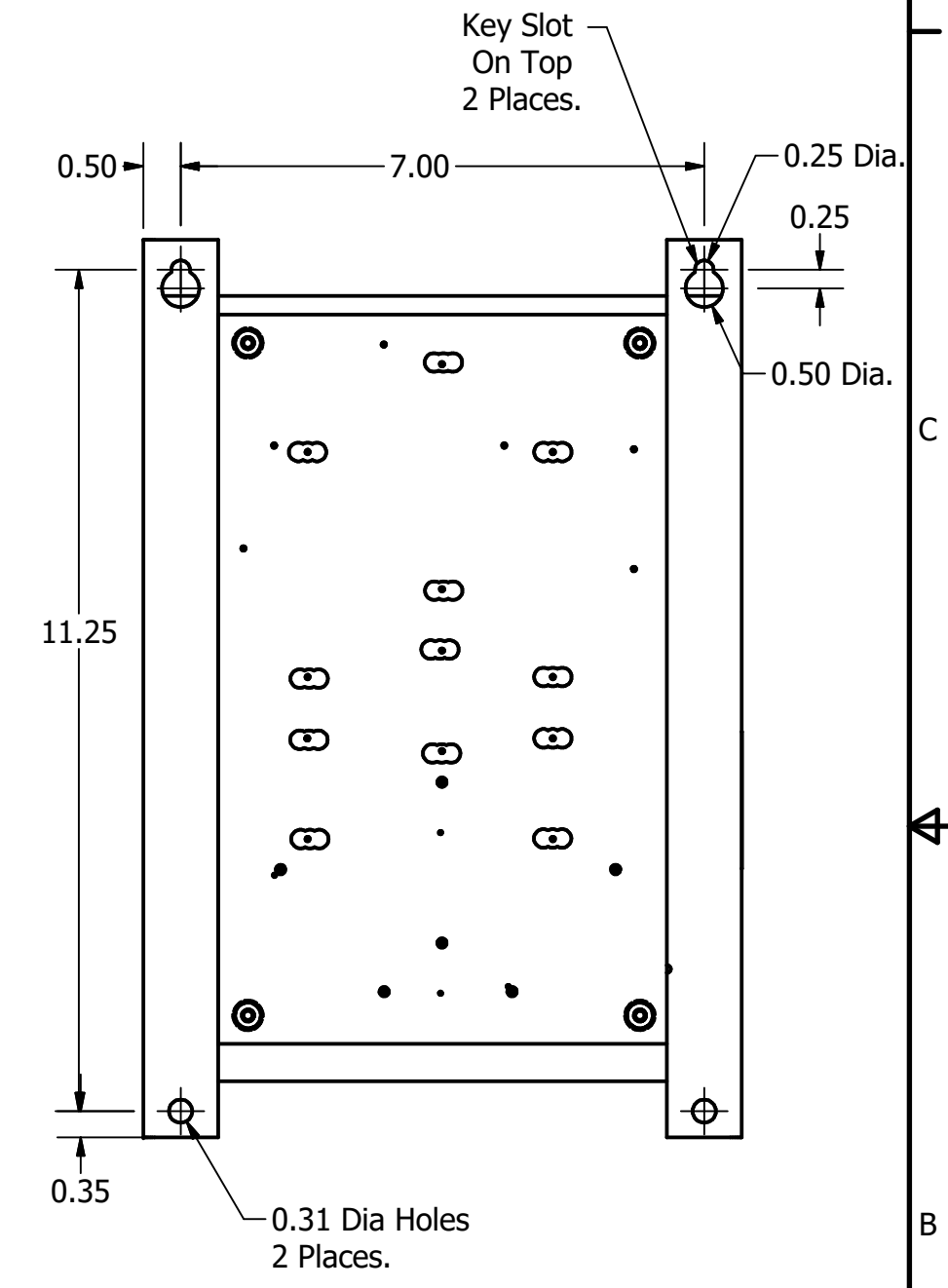
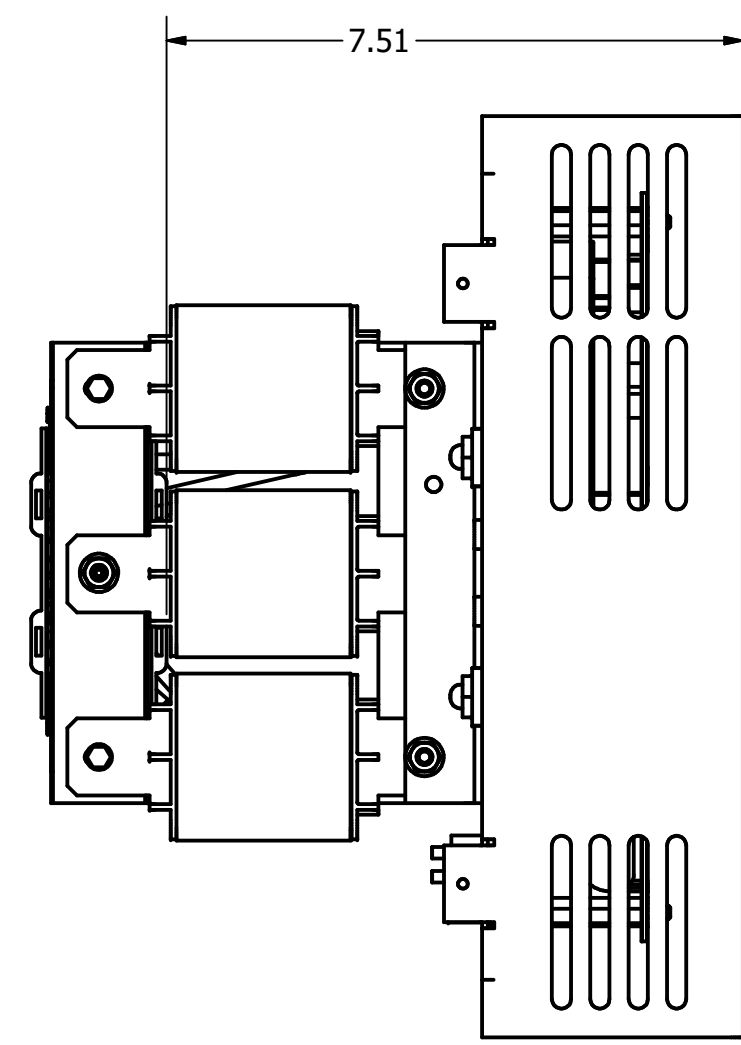
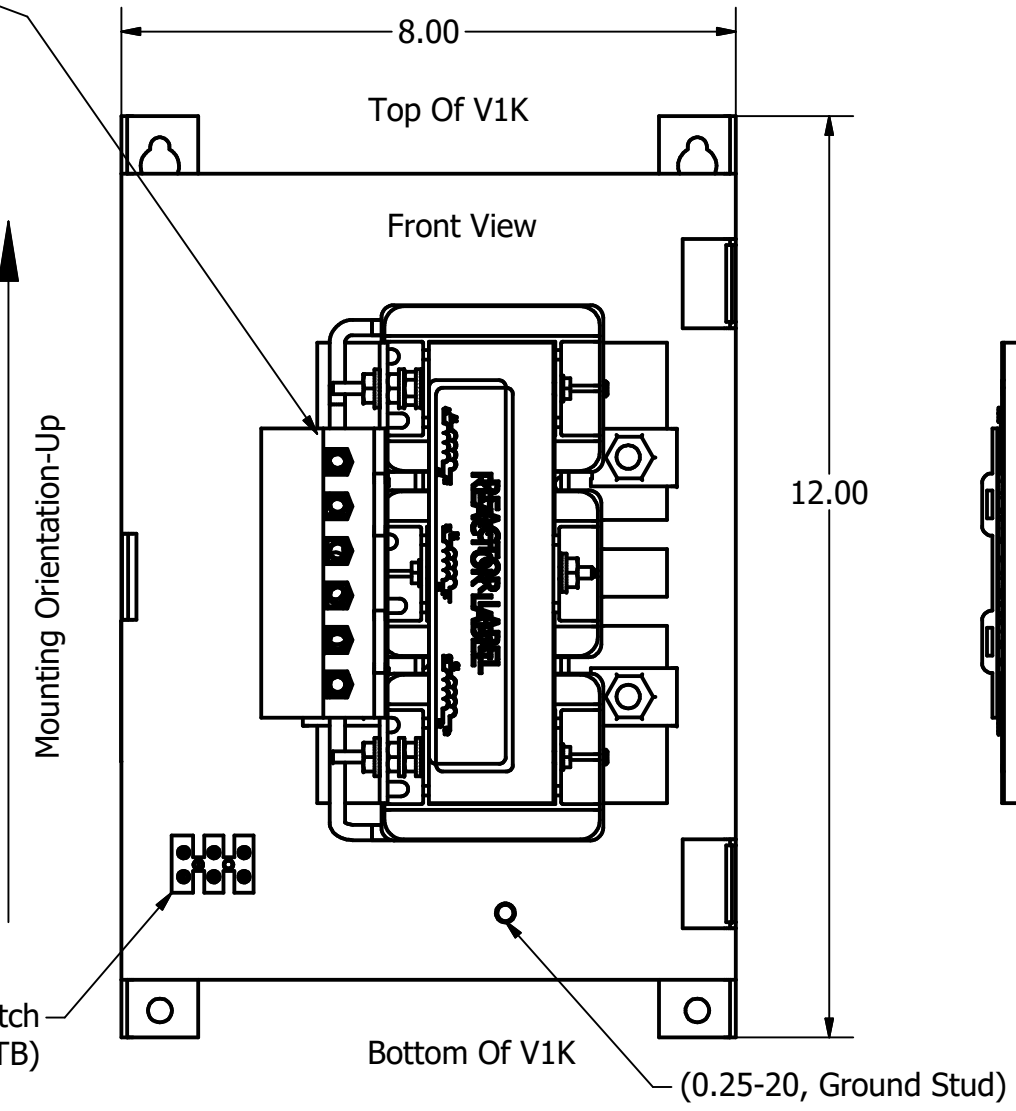
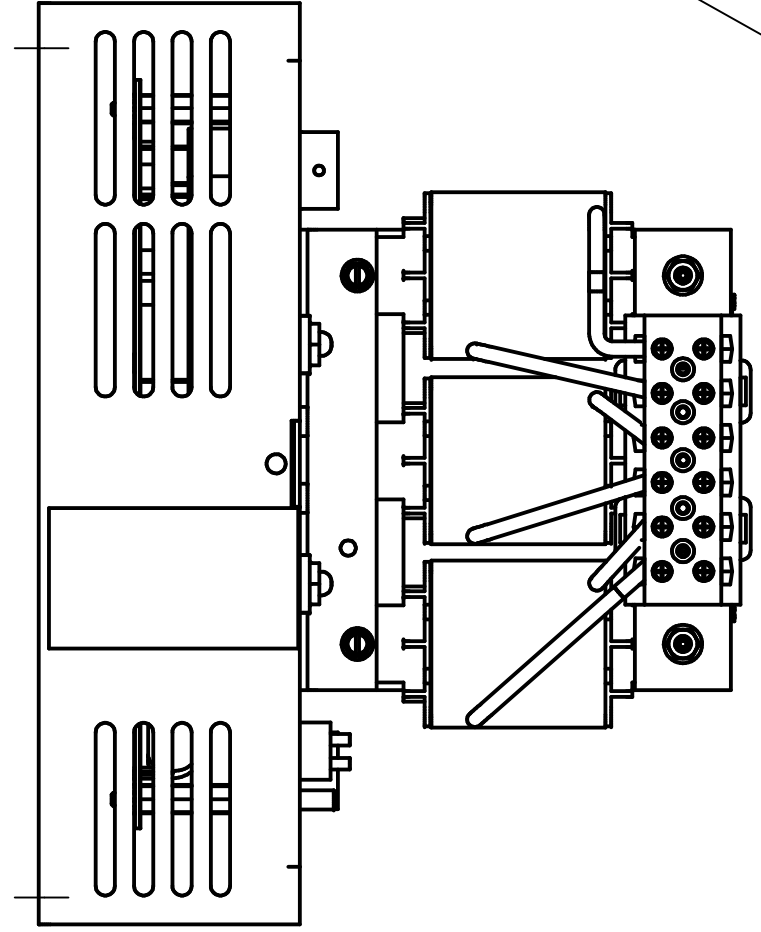

Customer Is Responsible For Installation to Meet All National And Local Electrical Codes.
 Material(s) Shall be RoHS Compliant

THE INFORMATION AND DESIGNS CONTAINED IN THIS DRAWING ARE CONFIDENTIAL AND THE PROPRIETARY PROPERTY OF ALLIED MOTION TECHNOLOGIES INC. AND ITS SUBSIDIARIES. NEITHER THIS DESIGN NOR ANY INFORMATION CONTAINED IN THIS DRAWING MAY BE REPRODUCED OR DISCLOSED TO OTHERS WITHOUT THE EXPRESS WRITTEN CONSENT OF ALLIED MOTION TECHNOLOGIES INC. AND ITS SUBSIDIARIES.				TOLERANCES (EXCEPT AS NOTED)	
REV	DESCRIPTION	DATE	BY	DECIMAL	ANGULAR
I	5898 Add T/S, Update Schematic	03/29/22	JRN	.XX ± .25	
H	4658 Rated To Max Voltage	03/04/19	JRN	.XXX ± .10	
G	4030, Combine V1k Drawings	6/7/17	DSW	FRACTIONAL ± 1/32	
NO	REVISION	DATE	BY	ANGULAR ± 1°	

4

3

2

1