

Ground Lug.
See IOM Manual, Part# 30895
Table S2/0, Wire Size And Torque.

Wire Range: 4-18 AWG.
Torque : 20 IN-LBS (2.3 Nm)

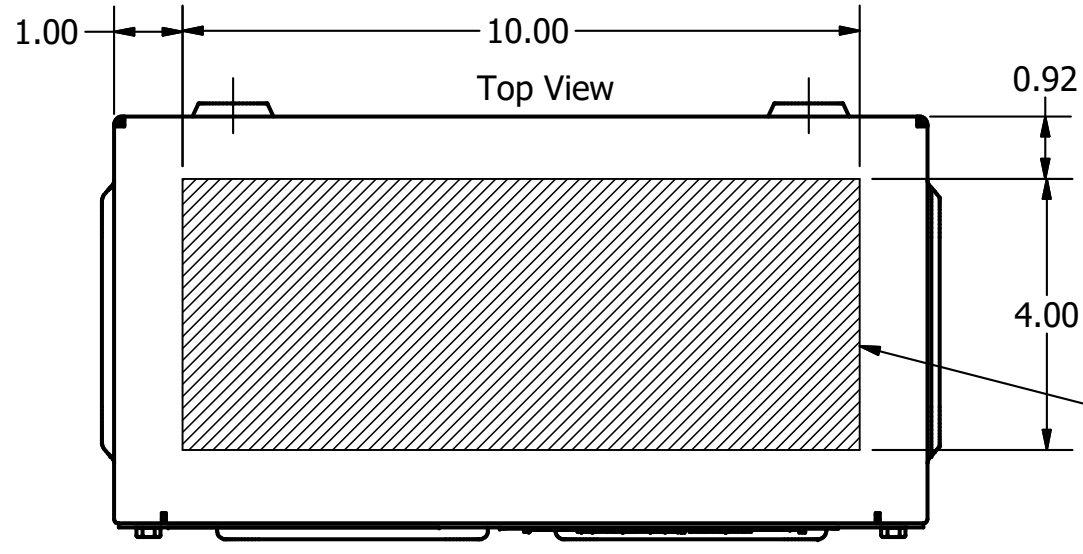

Suggested
Customer Wire Entrance
Top Of Enclosure.
See Note: 6
(Non Removeable Panel)

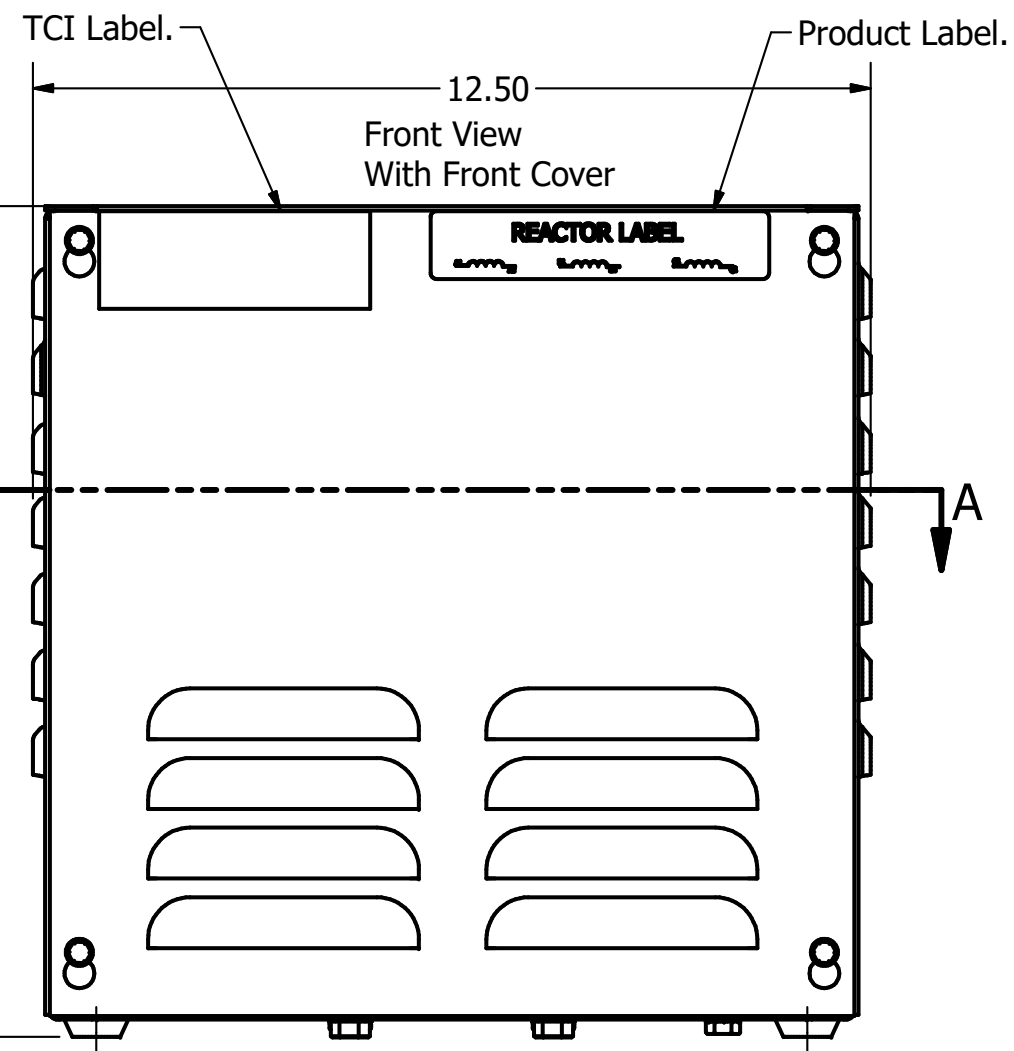

Front View
Without Front Cover

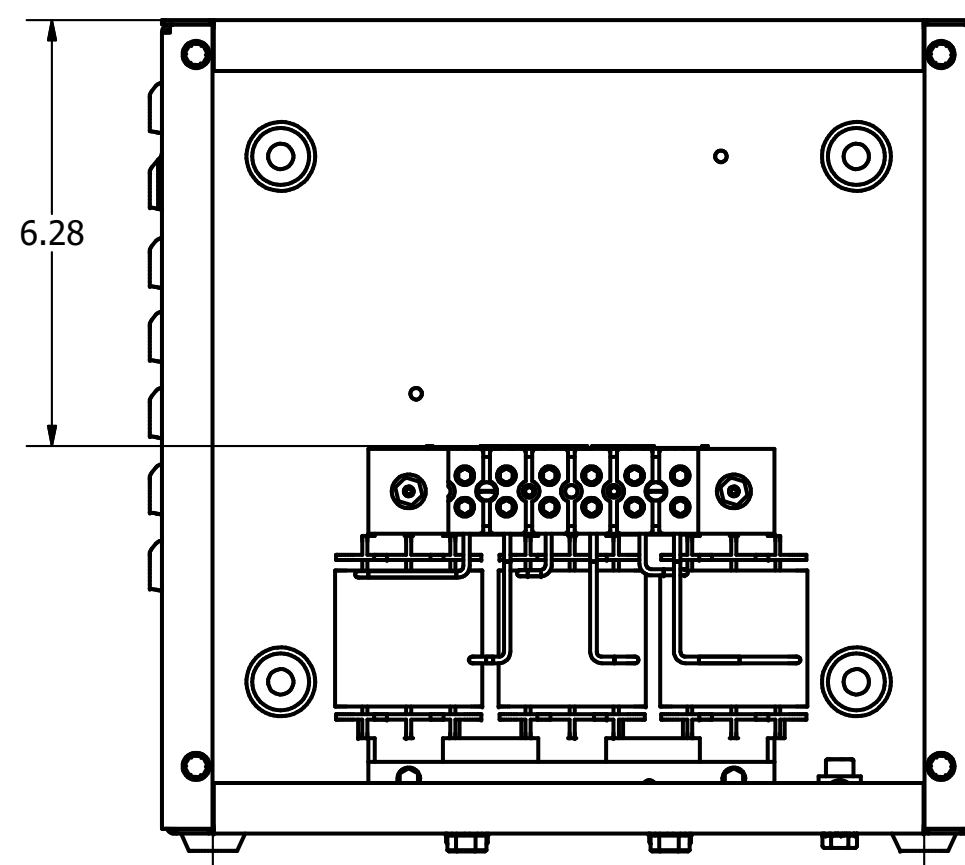

0.38 Dia Holes
4 Places, (Back of Enclosure)

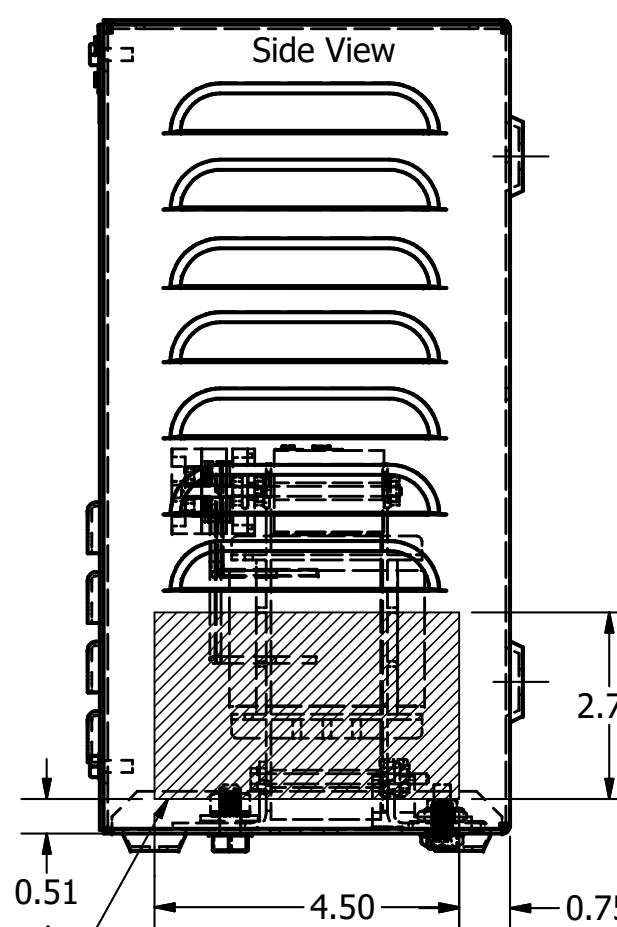

Back View

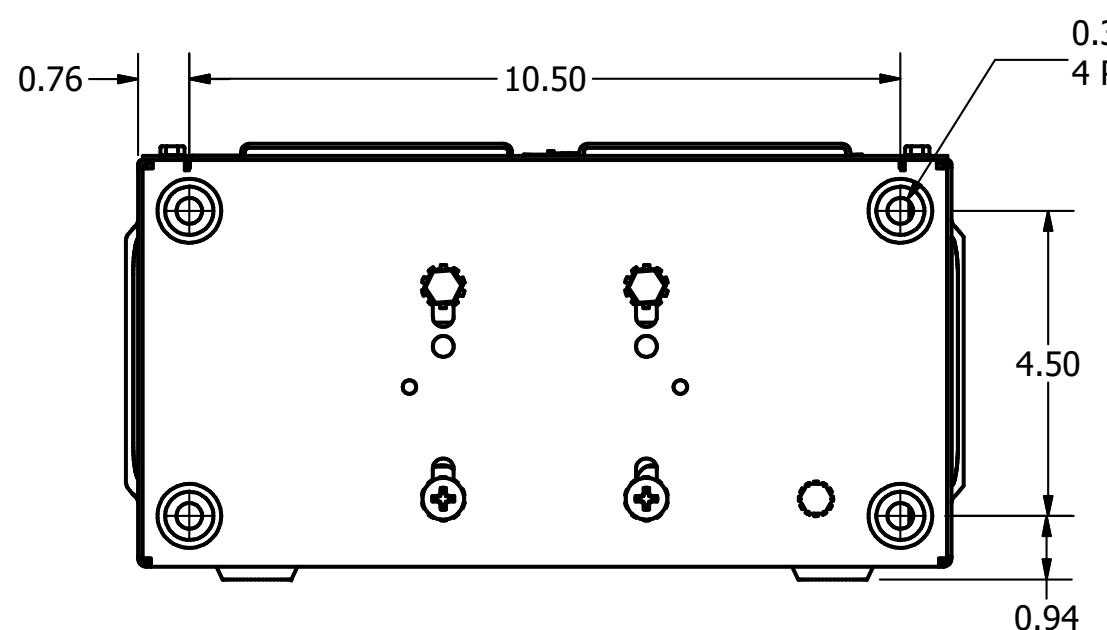
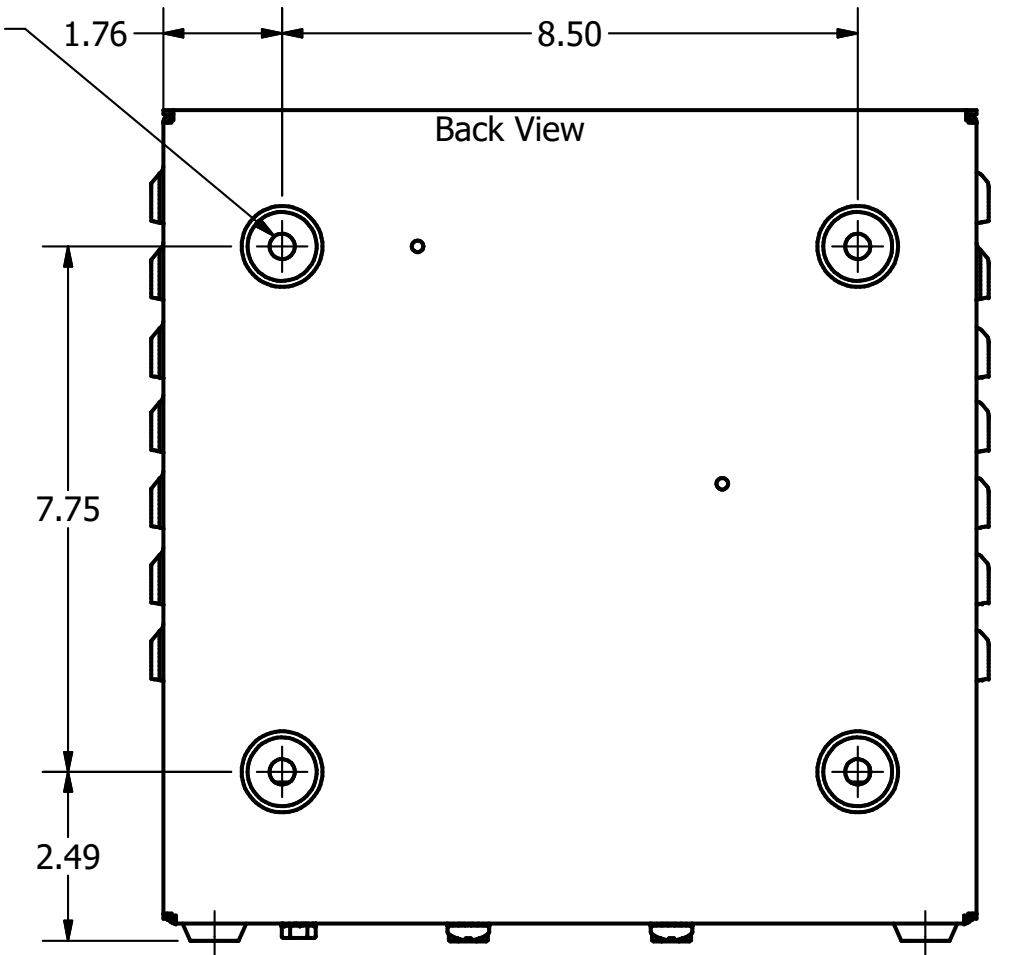

0.38 Dia Holes
4 Places, (Bottom of Enclosure)

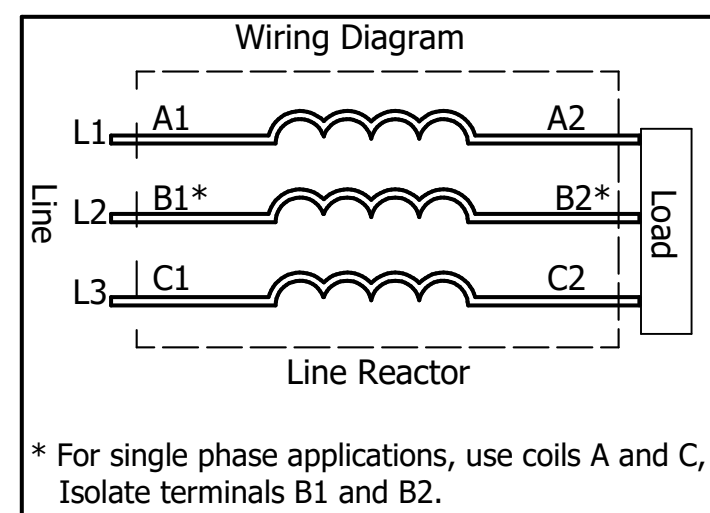

* For single phase applications, use coils A and C,
Isolate terminals B1 and B2.

Markings On
Terminal Block For
Reference Only.

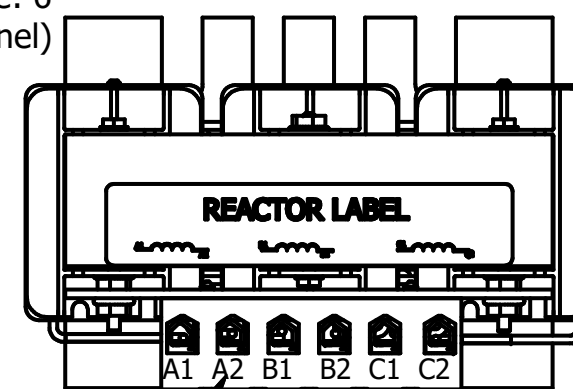

480 Rated Voltage, 600 Max Voltage, High Z, Impedance.						
Part Number	Horsepower (HP)	Motor Amps (A)	Maximum Amps (A)	Inductance (uH)	Weight (LBS)	Losses (W)
KDRE2HE01	30	40	45	850	26.4	141

575 Rated Voltage, 600 Max Voltage, High Z, Impedance.						
Part Number	Horsepower (HP)	Motor Amps (A)	Maximum Amps (A)	Inductance (uH)	Weight (LBS)	Losses (W)
KDRE42HE01	30	32	32	1430	26.4	140

TCI (800) 824-8282 transcoil.com

TCI, LLC
Germantown, WI, USA.
transcoil.com
800-824-8282

KDRUL Drive Reactor
KDR- Motor Amps ---
3PH, 50/60Hz, ---V Rated, 600V Max, -A Max, Ref IS
40C Amb Max, 135C Rise
Manual #30895

UL LISTED CE
3RD CLASS, 50, 600V

DATE CODE A1 A2 B1 B2 C1 C2

Notes:

1. UL file number: cULus Listed File E116124.
2. KDR Drive Reactors Comply With The Thermal and Altitude Standards Set Forth by NEMA ST20-1992.
3. KDR IOM Manual Part Number 30895
4. NEC Current For 208/240 Volts, Horsepower Based On 208 Volts.
5. Material(s) Shall be RoHS Compliant
6. Customer Is Responsible For Installation To Meet All National And Local Electrical Codes.

TOLERANCES (EXCEPT AS NOTED)			
DECIMAL			
	XX ± .25		
	.XXX ± .10		
FRACTIONAL			
	± 1/16		
ANGULAR			
	± 1°		
A	As Designed	3/12/18	DSW
NO	REVISION	DATE	BY

TCI, LLC CLAIMS PROPRIETARY RIGHTS IN THE MATERIAL HEREIN DISCLOSED. IT IS SUPPLIED WITHOUT PREJUDICE TO ANY PATENT RIGHTS OF TCI AND MAY NOT BE REPRODUCED OR USED TO MANUFACTURE ANYTHING SHOWN THEREIN WITHOUT WRITTEN PERMISSION FROM TCI.