

VSP02A

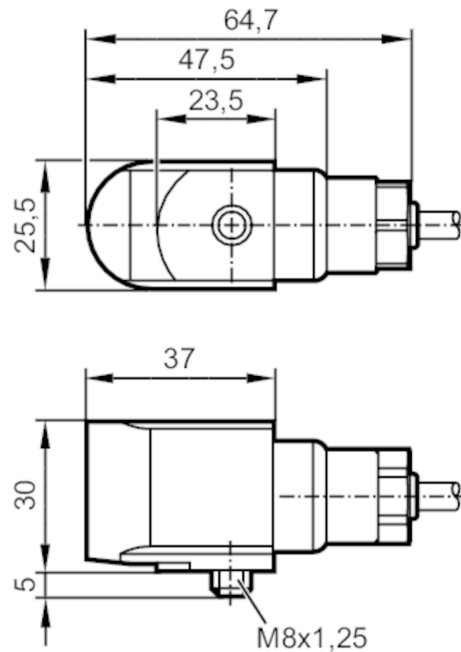

Accelerometer

VIBRATION SENSOR ATEX



Product characteristics

Measuring range of vibration	[g]	-50...50
Frequency range	[Hz]	2...10000
Measuring principle		piezoelectric

Application

Design	for connection to external diagnostic electronics VSExxx
--------	--

Electrical data

Switching amplifiers	Connection to intrinsically safe supply isolators (Ex ia)	
Operating voltage	[V]	10...12 DC
Current consumption	[mA]	0.5...8
Protection class		III
Reverse polarity protection		yes

Outputs

Max. load	[Ω]	200
Short-circuit protection		yes
Overload protection		yes

Measuring/setting range

Measuring range of vibration	[g]	-50...50
Frequency range	[Hz]	2...10000
Measuring principle		piezoelectric
Sensitivity	[mV/g]	100
Noise density	[mg]	0.1
Max. transverse sensitivity	[%]	5
Minimum measuring time	[s]	2

VSP02A



Accelerometer

VIBRATION SENSOR ATEX

Number of measurement axes	1
----------------------------	---

Operating conditions

Ambient temperature [°C]	-55...90
Storage temperature [°C]	-55...90
Protection	IP 68; (1D application: IP 65)

Tests / approvals

Approval	Baseefa12ATEX0247; IECEx BAS 12.0132
ATEX marking	 I M1 Ex ia I Ma (-55°C < Ta < +90°C)
EMC	EN 61000-6-2 EN 61000-6-4
Shock resistance	5000 g

Mechanical data

Weight [g]	669
Type of mounting	M8 x 1,25
Dimensions [mm]	30 x 25.5 x 64.7
Material	housing: stainless steel
Tightening torque [Nm]	8

Accessories

Accessories (optional)	Safety barrier, ZB0633
------------------------	------------------------

Remarks

Pack quantity	1 pcs.
---------------	--------

Electrical connection

Cable: 10 m, PUR	
white	IEPE +
black	IEPE -
screen	drain wire