

VSA005

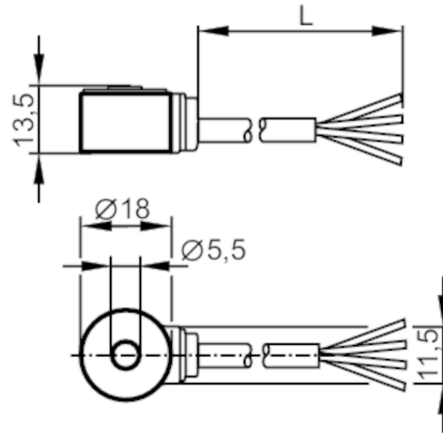

Accelerometer

VIBRATION SENSOR



Product characteristics

Measuring range of vibration	[g]	-25...25
Frequency range	[Hz]	1...10000
Measuring principle		capacitive

Application

System	screened cable; Drag chain suitability
Design	for connection to external diagnostic electronics VSE
Application	vibration detection

Electrical data

Operating voltage	[V]	7.2...10.8 DC
Current consumption	[mA]	< 15
Min. insulation resistance	[MΩ]	100; (500 V DC)
Protection class		III
Reverse polarity protection		yes
Type of sensor		Microelectromechanical system (MEMS)

Outputs

Analog current output	[mA]	0...10
Max. load	[Ω]	300

Measuring/setting range

Measuring range of vibration	[g]	-25...25
Frequency range	[Hz]	1...10000
Measuring principle		capacitive
Sensitivity	[μA/g]	142
Number of measurement axes		1

Accuracy / deviations

Linearity deviation		0,2 %
---------------------	--	-------

VSA005



Accelerometer

VIBRATION SENSOR

Operating conditions	
Ambient temperature [°C]	-20...80
Note on ambient temperature	cULus: < 80 °C
Storage temperature [°C]	-20...80
Max. relative air humidity [%]	80; (40 °C: 50 % non condensing)
Protection	IP 67
Tests / approvals	
EMC	EN 61000-6-2
	EN 61000-6-3
Shock resistance	DIN EN 60068-2-27 50 g 11 ms
Vibration resistance	DIN EN 60068-2-20 20 g / 10 ... 2000 Hz
MTTF [years]	2660
Mechanical data	
Weight [g]	323.5
Type of mounting	mounting screw
Material	housing: stainless steel (1.4404 / 316L)
Tightening torque [Nm]	5
Mechanische Überlastfestigkeit [g]	500
Drag chain suitability	yes
Drag chain suitability	Bending radius for fixed installation : min. 4 x cable diameter
	Bending radius for flexible applications : min. 15 x cable diameter
Accessories	
Items supplied	head cap screw: 1 x M5 x 20, Torx 15
Remarks	
Pack quantity	1 pcs.
Electrical connection	
Cable: 10 m, PUR, Ø 4 mm, screened; Maximum cable length: 250 m; drain wire applied to the housing; 4 x 0.14 mm ²	
blue	GND
black	test
brown	L+
white	Out
screen	drain wire