

O3M161

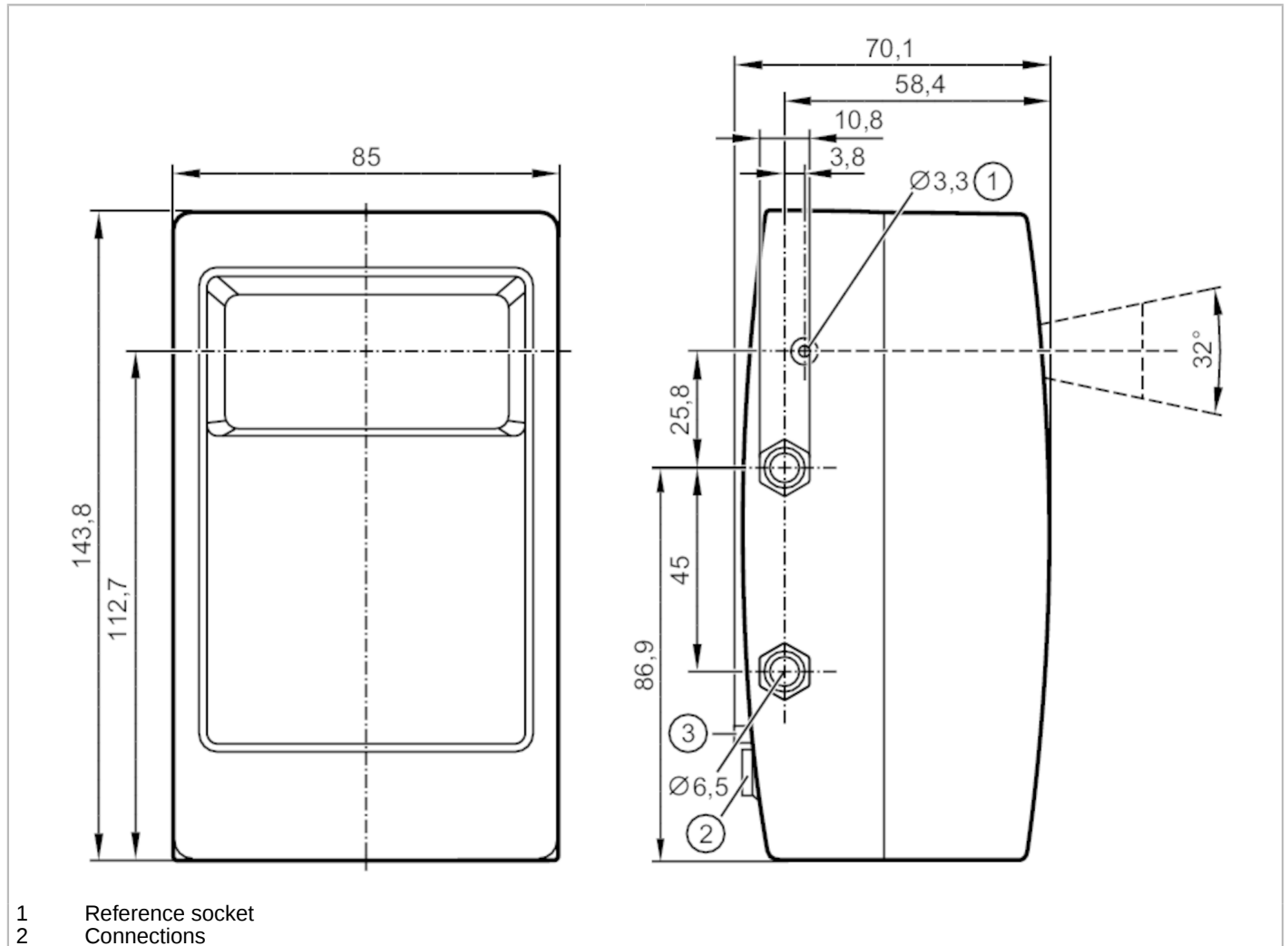

3D sensor for mobile applications

O3MXOOKG/CAN/E3/GM/95



- 1 Reference socket
- 2 Connections



Product characteristics

| | | |
|-------------------------------|------|----------------|
| Type of light | | Infrared light |
| Image resolution 3D | [px] | 64 x 16 |
| Angle of aperture 3D | [°] | 95 x 32 |
| Image repetition frequency 3D | [Hz] | 25 / 33 / 50 |

Application

| | |
|-------------|-------------------------|
| Application | output of 3D image data |
|-------------|-------------------------|

Electrical data

| | | |
|---------------------|------|-----------------|
| Operating voltage | [V] | 9...32 DC |
| Current consumption | [mA] | < 400 |
| Power consumption | [W] | 3.6 |
| Protection class | | III |
| Type of light | | Infrared light |
| Image sensor | | PMD 3D ToF-Chip |

O3M161



3D sensor for mobile applications

O3MXOOKG/CAN/E3/GM/95

| Monitoring range | | |
|-----------------------------------|--------------------|---|
| Image resolution 3D | [px] | 64 x 16 |
| Angle of aperture 3D | [°] | 95 x 32 |
| Image repetition frequency 3D | [Hz] | 25 / 33 / 50 |
| Software / programming | | |
| Parameter setting options | | via PC with ifm Vision Assistant |
| Interfaces | | |
| Communication interface | | CAN; Ethernet |
| Number of CAN interfaces | | 1 |
| Number of Ethernet interfaces | | 1 |
| Note on interfaces | | Output of preprocessed data via CAN interface |
| CAN | | |
| Transmission rate | | 250 (125...1000) kBaud |
| Protocol | | CANopen; UDS |
| Factory settings | | J1939 interface: default device address (ECU): 239 UDS interface: 500 (125...1000) kBaud |
| Usage type | | Parameter setting; Data transmission |
| Ethernet | | |
| Protocol | | UDP/IP |
| Factory settings | | IP address: 192.168.1.1 subnet mask: 255.255.255.0 target IP address: 255.255.255.255 target port: 42000 |
| Usage type | | Data transmission |
| Operating conditions | | |
| Ambient temperature | [°C] | -40...85 |
| Note on ambient temperature | | with high image repetition frequency of 25Hz |
| Storage temperature | [°C] | -40...105 |
| Protection | | IP 67; IP 69K; (with mounted connectors or protective caps) |
| Max. immunity to extraneous light | [klx] | 120 |
| Tests / approvals | | |
| EMC | DIN EN 61000-6-4 | industrial environments |
| | DIN EN 61000-6-2 | industrial environments |
| Shock resistance | DIN EN 60068-2-27 | 30 g / 6 ms bump |
| Vibration resistance | DIN EN 60068-2-6 | 10 g / 10...500 Hz swept sine |
| | DIN EN 60068-2-64 | 10...2000 Hz noise |
| Electrical safety | DIN EN 61010-2-201 | electric shock / electrical supply only via PELV circuits |
| MTTF | [years] | 78 |
| Mechanical data | | |
| Weight | [g] | 1059.85 |
| Dimensions | [mm] | 143.8 x 85 x 70.1 |

O3M161



3D sensor for mobile applications

O3MXOOKG/CAN/E3/GM/95

| | |
|----------|---|
| Material | housing: diecast aluminium; disc: gorilla glass |
|----------|---|

Accessories

| | |
|----------------|-------------------|
| Items supplied | Protective covers |
|----------------|-------------------|

Remarks

| | |
|---------|---|
| Remarks | The illumination unit is required for the operation of the sensor. Only use original ifm cables to connect sensor and illumination unit. The function-specific performance values can be found in the applicable documentation. |
|---------|---|

| | |
|---------------|--------|
| Pack quantity | 1 pcs. |
|---------------|--------|

Electrical connection - CAN

Connector: 1 x M12; coding: A

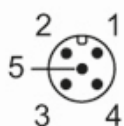

| | |
|---|----------|
| 1 | screen |
| 2 | 9...32 V |
| 3 | GND |
| 4 | CAN-H |
| 5 | CAN-L |

Electrical connection - Ethernet

Connector: 1 x M12; coding: D



| | |
|---|------|
| 1 | TD + |
| 2 | RD + |
| 3 | TD - |
| 4 | RD - |

Other data

Field of view size with lens distortion correction

| Measuring range / distance [m] | Length [m] | Width [m] |
|--------------------------------|------------|-----------|
| 5 | 11 | 2.9 |
| 10 | 21.8 | 5.7 |
| 15 | 32.7 | 8.6 |
| 30 | 65 | 17 |

O3M161



3D sensor for mobile applications

O3MXOOKG/CAN/E3/GM/95

measuring range for object recognition

| object type / object size | application condition | Measuring range [m] |
|---------------------------|-----------------------|---------------------|
| vehicle | sunny (~120 klx) | 0.25...21 |
| | cloudy (~20 klx) | 0.25...30 |
| | darkness | 0.25...35 |
| person | sunny (~120 klx) | 0.25...9 |
| | cloudy (~20 klx) | 0.25...12 |
| | darkness | 0.25...15 |
| retroreflector | sunny (~120 klx) | 1...29 |
| | cloudy (~20 klx) | 1...42 |
| | darkness | 1...55 |

software variant: OD object recognition

measuring range for ROI

| application condition | Measuring range [m] |
|-----------------------|---------------------|
| | typical value |
| sunny (~120 klx) | 0.25...8 |
| cloudy (~20 klx) | 0.25...11 |
| darkness | 0.25...21 |

software variant : DI / BF distance image basic functions

measuring accuracy

| application condition | measuring accuracy [cm] |
|-----------------------|-------------------------|
| | typical value |
| sunny (~120 klx) | ± 15 |
| cloudy (~20 klx) | ± 10 |
| darkness | ± 5 |

software variant : DI / BF distance image basic functions