

JN2201

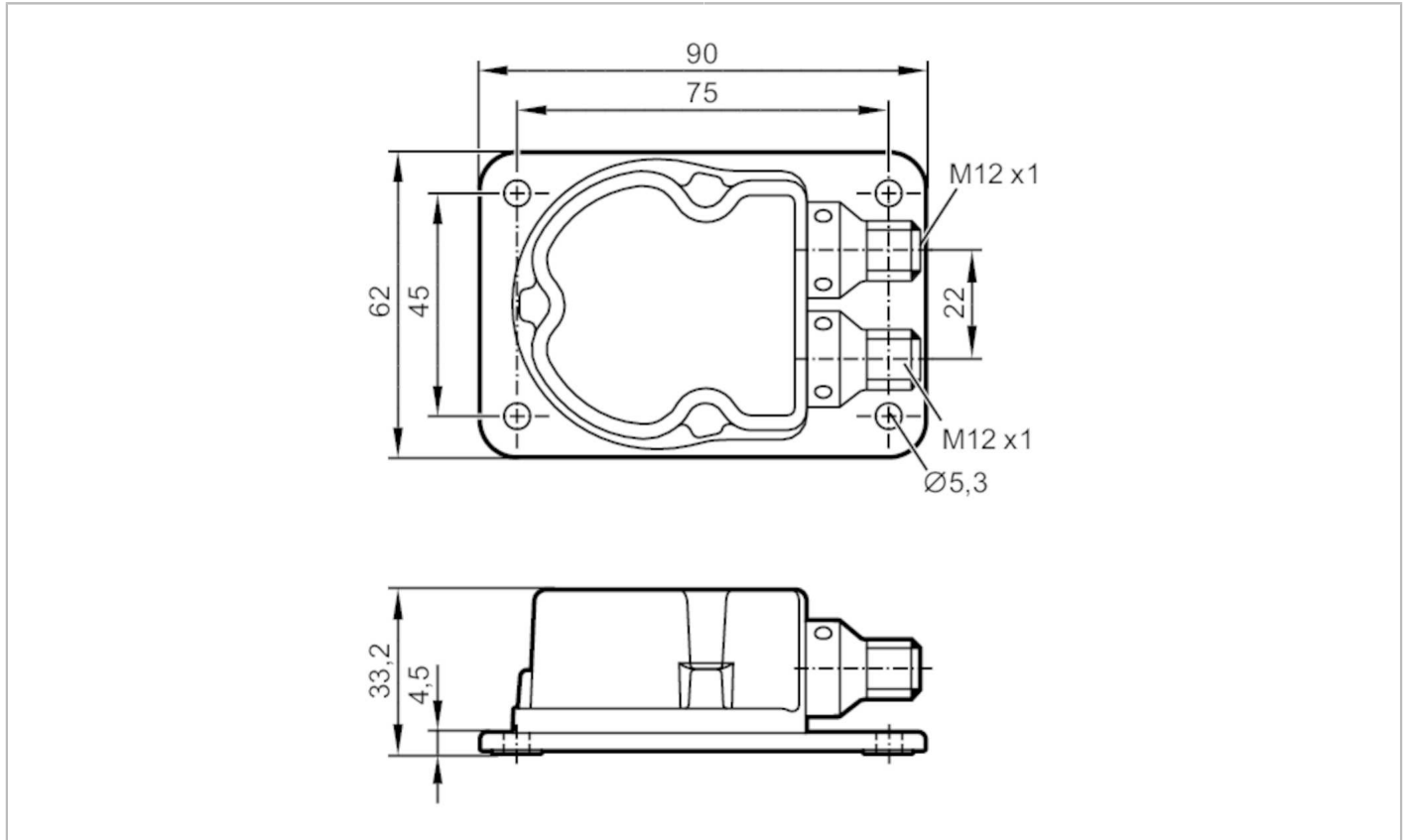

Inclination sensor

INC-M2M090ABIAKG/US



Product characteristics	
Measuring principle	MEMS capacitive
Communication interface	IO-Link
Inclination measurement	
Number of measurement axes	2
Angular range [°]	± 45
Application	
Function principle	static
Application	High-precision inclination measurement in 2 axes for mobile and industrial applications
Electrical data	
Operating voltage [V]	9.2...30 DC; (voltage output: 12...30 DC; IO-Link: 18...30 DC)
Current consumption [mA]	100; (24 V DC, 25 °C)
Max. current consumption [mA]	380; (9,2 V DC; -40 °C)
Protection class	III
Reverse polarity protection	yes
Reverse polarity protection	yes
Power-on delay time [s]	300; (warm-up time; Max. initialization time: 1000 ms)
Inputs / outputs	
Number of inputs and outputs	Number of digital outputs: 2; Number of analog outputs: 2



Inclination sensor

INC-M2M090ABIAG/US

Outputs	
Total number of outputs	4
Output signal	analog signal; switching signal
Electrical design	PNP/NPN
Number of digital outputs	2
Output function	normally open / closed; (programmable)
Max. voltage drop switching output DC [V]	2.5
Permanent current rating of switching output DC [mA]	125; (125 mA (85° C); 200 mA (60° C); 250 mA (40° C))
Number of analog outputs	2
Analog current output [mA]	4...20; (in case of a fault: 2 mA)
Max. load [Ω]	220; (220 (9,2...15 V) / 500 (15...30 V))
Analog voltage output [V]	2...10; (in case of a fault: 1 V)
Min. load resistance [Ω]	1000; (10000 (12...13,5 V) / 1000 (13,5...30 V))
Precision analog output [%]	≤ 1
Short-circuit protection	yes
Overload protection	yes
Measuring/setting range	
Measuring principle	MEMS capacitive
Inclination measurement	
Number of measurement axes	2
Angular range [°]	± 45
Limit frequency [Hz]	0.5...10; (configurable)
Accuracy / deviations	
Accuracy [°]	≤ ± 0,01; (absolute)
Hysteresis [°]	≤ ± 0,05
Repeatability [°]	≤ ± 0,01
Resolution [°]	0.01
Temperature coefficient [1/K]	≤ ± 0,0008 °
Software / programming	
Parameter setting options	angle (X/Y); hysteresis / window; Switch points; switching logic; fault indication; self-test; current/voltage output
Interfaces	
Communication interface	IO-Link
Transmission type	COM2 (38,4 kBaud)
IO-Link revision	1.1
SDCI standard	IEC 61131-9 CDV
Profiles	Smart Sensor: Process Data Variable; Device Identification, Device Diagnosis
SIO mode	yes
Required master port class	A
Process data analog	2
Process data binary	2

JN2201



Inclination sensor

INC-M2M090ABIAKG/US

Min. process cycle time	[ms]	5
Supported DeviceIDs	Type of operation	DeviceID
	default	417

Operating conditions		
Ambient temperature	[°C]	-40...85
Storage temperature	[°C]	-40...85
Protection		IP 65; IP 67; IP 68; IP 69K

Tests / approvals		
EMC	DIN EN 61000-4-2 ESD	4 kV CD / 8 kV AD
	DIN EN 61000-4-3 HF radiated	10 V/m
	DIN EN 61000-4-4 Burst	2 kV
	DIN EN 61000-4-6 HF conducted	10 V
	DIN EN 55022 class B / CISPR 16-2-3	30 - 1000 MHz
	CISPR 25 ECE R 10	30 - 1000 MHz narrowband and broadband
	ISO 11452-2 ECE R 10	20 - 2000 MHz / 30 V/m
	ISO 7637-2 ECE R 10	pulse 1, 2a, 2b, 3a, 3b, 4, and pulse emission during operation, switching-on, switching-off
	ISO 7637-3	- 80 V pulse a / + 80 V pulse b
Shock resistance	DIN EN 60068-2-27	100 g 1 ms / 10000 Impacts per axis (X/Y)
	DIN EN 60068-2-29	30 g 6 ms / 24000 shock (bump)
Vibration resistance	DIN EN 60068-2-64	10...2000 Hz Test VII / random, mounting place car body
	DIN EN 60068-2-6	10...500 Hz / 10 g 10 cycles/axis, sine
Salt spray test	DIN EN 60068-2-52	severity level 5 (motor vehicle)
Damp heat	DIN EN 60068-2-30	55 °C cyclic upper temperature / 95 % rh 2 cycles of 24 h
MTTF	[years]	176
Standard		Compliant with ECE R 10, rev. 5; ISO 7637-3: 2007-07

Mechanical data		
Weight	[g]	451
Dimensions	[mm]	90 x 62 x 33.2
Material		housing: diecast zinc nickel-plated
Mounting orientation		Horizontal

Displays / operating elements		
Display	Power	1 x LED, green
	Set point	1 x LED, yellow

Accessories		
Items supplied		Protective cover

Remarks		
Pack quantity		1 pcs.

JN2201



Inclination sensor

INC-M2M090ABIAGK/US

Electrical connection - digital

Connector: 1 x M12; coding: A



1	L+ 24 V DC (+Ub-D)
2	Switching output OUT 2
3	L - GND
4	Switching output OUT 1 / IO-Link

Electrical connection - analog

Connector: 1 x M12; coding: A



1	L+ 24 V DC (+Ub-A)
2	analog output A2
3	L - GND
4	analog output A1

Other data

Measuring/setting range

Inclination measurement			min.	max.
Set point	SP1	[°]	-89.00	90.00
Reset point	rP1	[°]	-90.00	89.00
Set point	SP2	[°]	-89.00	90.00
Reset point	rP2	[°]	-90.00	89.00
Analog start point	ASP1	[°]	-90.00	89.00
Analog end point	AEP1	[°]	-89.00	90.00
Analog start point	ASP2	[°]	-90.00	89.00
Analog end point	AEP2	[°]	-89.00	90.00
In steps of		[°]	0.01	

JN2201



Inclination sensor

INC-M2M090ABIAKG/US

Diagrams and graphs

measuring and installation direction

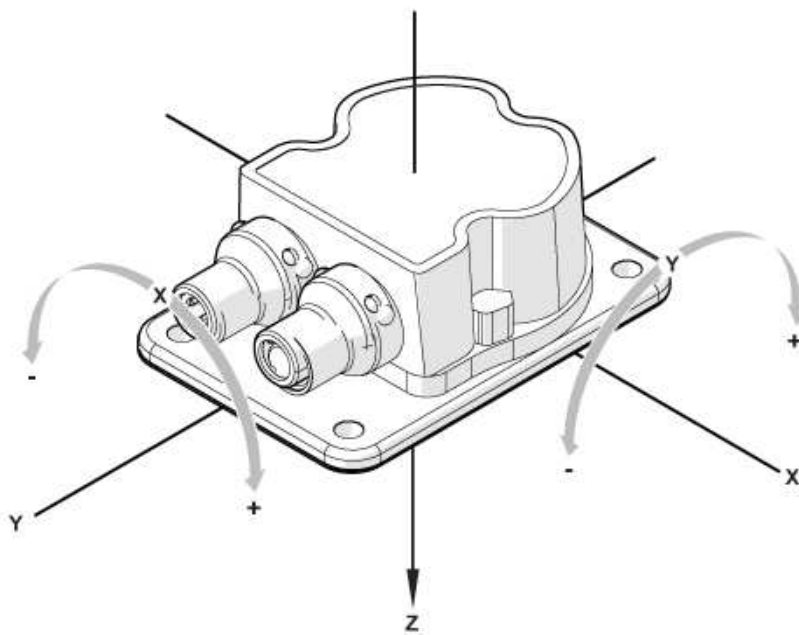

horizontal installation position / rotation about x- and y-axis