

Pitman Arm Spreader

- For Chevrolet, Dodge, Ford, Freightliner, Isuzu, Kenworth, Mack Peterbilt, Volvo

MODEL 40318

ESCO
PRO
SERIES

NEW
ARRIVAL!



Designed to fit Chevy 3500/5500, Dodge Ram 3500/5500, Ford F-350/550, Isuzu NPR, Kenworth, Peterbilt, Freightliner, Mack, Volvo and many other class 3-8 transportation trucks and equipment.



MODEL 40318

BENEFITS & FEATURES:

- ▶ Heavy-Duty designed adjustable pulling arms designed to fit various pitman arm widths.
- ▶ Eliminate dangerous hammering or cutting torch methods.
- ▶ Designed to be used with up to a 1/2 in. impact tool, impact wrench, hand ratchet, or breaker bar.
- ▶ Easy slip on and adjustable size makes ideal for multiple pitman arm extraction applications.
- ▶ Made of high quality heavy duty steel capable of withstanding rigorous and daily use in shop environments.

(More Details on Back)

Specifications:

MODEL 40318

The **ESCO Pitman Arm Spreader - For Chevrolet, Dodge, Ford, Freightliner, Isuzu, Kenworth, Mack Peterbilt, Volvo (Model 40318)** is designed to fit Chevy 3500/5500, Dodge Ram 3500/5500, Ford F-350/550, Isuzu NPR, Kenworth, Peterbilt, Freightliner, Mack, Volvo and many other class 3-8 transportation trucks and equipment. Designed as an easy and versatile heavy-duty slip-on spreader, this tool can be used with up to a 1/2 in. impact wrench, hand ratchet or breaker bar. The versatility of this tool allows for fitting on a wide range of pitman arm widths and is manufactured with the highest-strength steel components to ensure longevity and reliability.

USE WITH RATCHET OR IMPACT

Designed to be used with any air ratchet or impact tool up to 1/2 inch.



SIMPLE & VERSATILE DESIGN

Designed as an easy and versatile heavy-duty slip-on spreader

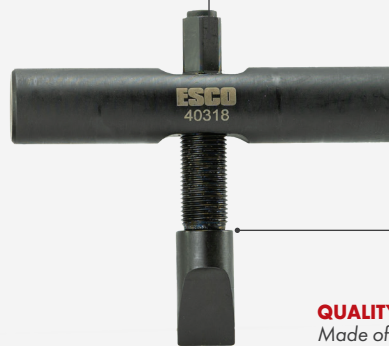

QUALITY DESIGN

Made of high quality heavy duty steel capable of withstanding rigorous and daily use in shop environments. CR-MO (Chromium-Molybdenum) alloy steel.

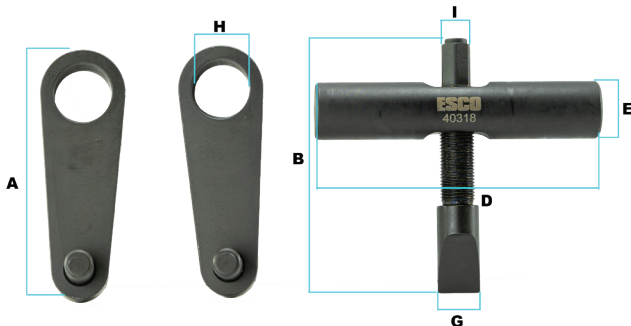

SPECIFICATIONS:

A	4 1/16 in.	E	3/16 in.
B	4 1/16 in.	F	2 1/4 in.
C	1 in.	G	3/4 in.
D	5 in.	H	1 3/8 in.

Impact Drive Size	1/2 in.
Weight	3 lbs.
Product Dimensions (L x W X H)	See specifications above
Packaging Dimensions (L x W X H)	6 x 7 x 1 1/2 in.
Material	CR-MO (Chromium-Molybdenum) alloy steel
Application	Commonly found on class 3-8 trucks and equipment. (Ram 3500/5500, Chevrolet 3500/5500, Ford F-350/550, Isuzu NPR, Kenworth, Peterbilt, Freightliner, Mack, Volvo, etc.)
UPC	816904025205
Warranty	Limited Lifetime

NOTE: ESCO reserves the right to change, alter, or modify product(s) without notice. This includes but is not limited to product: color, design, parts, accessories, etc.

sales@esco.net **WWW.ESCO.NET** 1.800.352.9852



COPYRIGHT 2022 • 15270 Flight Path Drive • Brooksville, FL 34604

