

## FRYERS

**VULCAN****ER KLEENSCREEN PLUS® FILTRATION SYSTEM  
BUILT-IN FILTRATION SYSTEM FOR 2ERF, 3ERF & 4ERF FRYERS**

**Model 2ER85CF**  
Shown on casters (Accessory)

**SPECIFICATIONS**

Built-in filter system, Vulcan Model No. (# of fryers – 2, 3 or 4) ER (50 or 85) (control type A, D, or C) F (add suffix -F to fryer battery Model No., i.e. 2ER50DF). Filter system accommodates a maximum of four cabinets for ER50F and maximum of three for ER85F. Drawer style filter pan assembly holds 70 lbs. shortening capacity for ER50F and 110 lbs. capacity for ER85F. Filter vessel constructed of drawn (seamless) 18 gauge stainless steel. The 2ER50F filter pan weighs only 12.2 lbs. and the filter pan for the 2ER85F weighs only 20.5 lbs. 1/3 H.P. motor and pump circulates hot frying compound at the rate of 8 gallons per minute, activated by a one touch push button switch. System provided standard with stainless steel mesh filter screen. Optional KleenScreen PLUS® envelopes filter out particulate down to .5 microns. Standard equipment comes on legs, has a tank brush and cleanout rod. Hands free oil return line connection. Drain valve interlock switch turns fryer's heating elements off when drain valve is opened. Power supply is 208 volt, 60 Hz, 3 phase.

UL listed. NSF listed.

**STANDARD FEATURES**

- Filter system accommodates maximum of four fryer cabinets (ER50F), maximum of three (ER85F).
- Boil Out ByPass™ easily removes boil out solution from fry tank without contact of drain manifold, filter pan or motor/pump.
- Drain valve interlock switch (DVI). Turns off heating elements automatically when draining oil or lifting heating elements during cleaning.
- Drawn (seamless) 18 gauge stainless steel filter pan. 70 lbs. frying compound capacity on ER50F, 110 lbs. capacity on ER85F.
- 6" adjustable legs.
- Stainless steel mesh 2-sided filter screen – surface area 270 sq. in.
- 1/3 H.P. motor and pump circulates frying compound at a rate of 8.0 gallons per minute.
- One touch push button switch to engage pump and motor (solid state controls).
- Tank brush and clean-out rod.
- One year limited parts and labor warranty.
- 6' High Temperature Discard Hose.
- 10 year fry tank limited warranty.

**ACCESSORIES (Packaged & Sold Separately)**

- Stainless steel tank cover – doubles as a work surface top.
- Micro-Filtration Fabric Envelopes – 6 filters/per package.
- Casters, adjustable (2 locking, 2 non-locking).
- "Add-On" Frymate™ – VX15 or VX21S.
- Rear oil reclamation discard connection (factory installed).
- Prison Security Package (factory installed).
- Single Basket Lift (factory installed).

**OPTIONS**

- 480 volt, 3 phase (NEMA 5-15P). (Separate 120 volt, 20 amp electric supply required.)
- Second year extended limited parts and labor warranty.

**REFERENCE MATERIALS**

- See 1ER50 Spec Sheet F32900 for electrical specs.
- See 1ER85 Spec Sheet F32901 for electrical specs.
- See 1ERF Spec Sheet F32969 for single unit KleenScreen PLUS®.



**ER KLEENSCREEN PLUS® FILTRATION SYSTEM**  
**BUILT-IN FILTRATION SYSTEM FOR 2ERF, 3ERF & 4ERF FRYERS**

**INSTALLATION INSTRUCTIONS**

1. An adequate ventilation system is required for Commercial Cooking Equipment. Information may be obtained by writing to the National Fire Protection Association, Batterymarch Park, Quincy, MA 02269. When writing refer to NFPA No. 96.
2. All models require a 6" clearance at both sides and rear adjacent to combustible construction.
3. All models require a 16" (407 mm) minimum clearance to adjacent open top burner units.
4. This appliance is manufactured for commercial installation only and is not intended for home use.

**SERVICE CONNECTIONS:**

- ⓔ1 480 volt ER KleenScreen PLUS® require a separate 120 V, 60Hz, 1 phase (NEMA 5-15P) electrical power connection to operate the filter motor/pump and digital controls, (not supplied with the fryer).

**NOTE:** In line with its policy to continually improve its product, Vulcan reserves the right to change materials and specifications without notice.

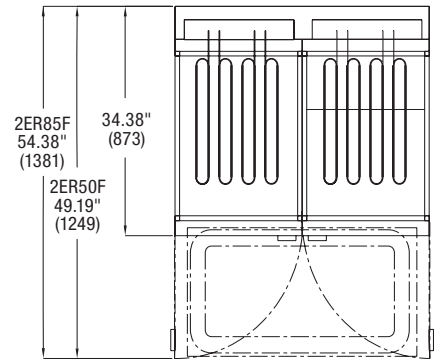
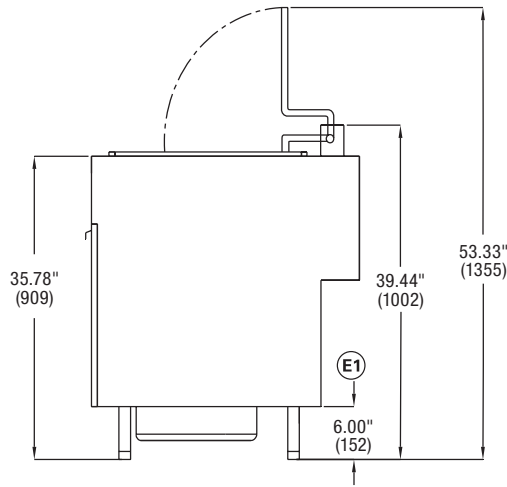
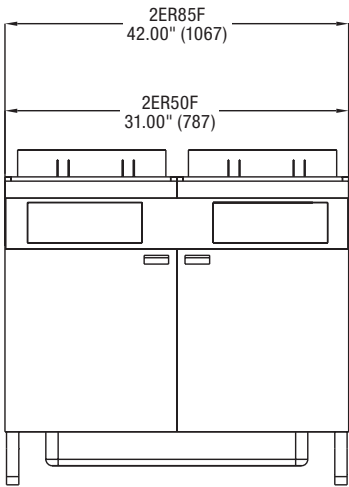

**FILTER SYSTEM SPECIFICATION:**  
 Screen = 270 sq.  
 Micro Filtration Fabric Envelope = 350 sq. in

**MOTOR/PUMP SPECIFICATIONS:**  
 480V = 1/3 HP 1750 RPM 8.0 gal./min 120V / 5.0A 50/60Hz 1 Ph.  
 208V = 1/3 HP 1750 RPM 8.0 gal./min 208V / 3.6A 50/60Hz 1 Ph.

| Model  | Filter Pan Capacity | Electrical                           | Battery Dimensions (Widths) |          |          |
|--------|---------------------|--------------------------------------|-----------------------------|----------|----------|
|        |                     |                                      | 2 Fryers                    | 3 Fryers | 4 Fryers |
| 2ER50F | 70 lbs.             | 17kW<br>Refer to spec. sheet F-32900 | 31"                         | 46½"     | 62"      |
| 3ER50F |                     |                                      |                             |          |          |
| 4ER50F |                     |                                      |                             |          |          |
| 2ER85F | 110 lbs.            | 24kW<br>Refer to spec. sheet F-32901 | 42"                         | 63"      | —        |
| 3ER85F |                     |                                      |                             |          |          |

**NOTE:** Fryer in battery with fuses (master) must add 5 amps for the motor / pump. Remaining fryers (slave) use amps per spec. sheet.