



# RAYZOR 760™

user manual

©2022 ELATION PROFESSIONAL all rights reserved. Information, specifications, diagrams, images, and instructions herein are subject to change without notice. ELATION PROFESSIONAL logo and identifying product names and numbers herein are trademarks of ELATION PROFESSIONAL. Copyright protection claimed includes all forms and matters of copyrightable materials and information now allowed by statutory or judicial law or hereinafter granted. Product names used in this document may be trademarks or registered trademarks of their respective companies and are hereby acknowledged. All non-ELATION brands and product names are trademarks or registered trademarks of their respective companies.

**ELATION PROFESSIONAL** and all affiliated companies hereby disclaim any and all liabilities for property, equipment, building, and electrical damages, injuries to any persons, and direct or indirect economic loss associated with the use or reliance of any information contained within this document, and/or as a result of the improper, unsafe, insufficient and negligent assembly, installation, rigging, and operation of this product.

**Elation Professional USA** | 6122 S. Eastern Ave. | Los Angeles, CA. 90040  
323-582-3322 | 323-832-9142 fax | [www.elationlighting.com](http://www.elationlighting.com) | [info@elationlighting.com](mailto:info@elationlighting.com)

**Elation Professional B.V.** | Junostraat 2 | 6468 EW Kerkrade, The Netherlands  
+31 45 546 85 66 | +31 45 546 85 96 fax | [www.elationlighting.eu](http://www.elationlighting.eu) | [info@elationlighting.eu](mailto:info@elationlighting.eu)

**Elation Professional Mexico** | AV Santa Ana 30 | Parque Industrial Lerma, Lerma, Mexico 52000  
+52 (728) 282-7070

## DOCUMENT VERSION



Due to additional product features and/or enhancements, an updated version of this document may be available online. Please scan the QR Code with your mobile device or visit [www.elationlighting.com](http://www.elationlighting.com) for the latest revision/update of this manual, before installation and/or programming.

Date	Document Version	Software Version ≥	DMX Channel Modes	Notes
01/18/19	1.1	TBD	TBD	Initial preliminary release.
03/27/19	1.2	1.1.1E	25 / 52 / 28 / 80	Updated preliminary release.
04/20/19	1.4	1.1.1F	25 / 52 / 28 / 80	Final full release.
04/24/19	1.6	N/C	NO CHANGE	Added Patching and FX Generator sections.
04/29/19	1.8	N/C	NO CHANGE	Updated System Menu section.
10/15/19	2.0	1.1.1	NO CHANGE	Updated System Sub Menus, DMX Control Channel, and RGBW/SparkLED FX Tables.
08/14/20	2.2	N/C	NO CHANGE	Updated thermal
08/19/20	2.4	N/C	NO CHANGE	Updated electrical
10/30/20	2.6	N/C	NO CHANGE	Updated specifications
02/04/21	2.8	1.1.4	NO CHANGE	Updated primary/secondary modes
11/08/22	3.0	1.3	25 / 52 / 80	Updated Introduction, System Menu, DMX Ch. Functions and Values, RGBW Pixel FX Table, Specifications; added RDM, Fixture Transportation, Fan Control, Dimmer Curves, Software Updates

# CONTENTS

General Information	4
Warranty (USA Only)	5
Safety Guidelines	6
Fixture Transportation	8
Maintenance Guidelines	9
Fixture Overview	10
Installation Guidelines	11
Remote Device Management (RDM)	15
System Menu	16
Fan Control	26
Lighting Console Patching Guidelines	27
DMX Channel Functions and Values	32
Color Temperature Control Table	43
FX Generator Guidelines	44
RGBW Pixel FX Table	46
SparkLED FX Table	51
Dimmer Curves	56
Error Codes	57
Software Updates	58
Specifications	63
Dimensional Drawings	64
Optional Accessories   FCC Statement	65

# GENERAL INFORMATION

## INTRODUCTION

Please read and understand the instructions in this manual carefully and thoroughly before attempting to operate this device. These instructions contain important safety and use information. **This device is intended for use by trained professionals only, and it is not suitable for private use.**

## UNPACKING

Every device has been thoroughly tested and has been shipped in perfect operating condition. Carefully check the shipping carton for damage that may have occurred during shipping. If the carton is damaged, carefully inspect the device for damage, and be sure all accessories necessary to install and operate the device have arrived intact. In the event damage has been found or parts are missing, please contact our customer support team for further instructions. Please do not return this device to your dealer without first contacting customer support. Please do not discard the shipping carton in the trash. Please recycle whenever possible.

## BOX CONTENTS

Omega Brackets (x2)  
Single Clamp Bracket Kit (mini-bracket, 2 bolts, 2 lock nuts)  
Power Cable

## CUSTOMER SUPPORT

Contact ELATION Service for any product related service and support needs. Also visit [forums.elationlighting.com](https://forums.elationlighting.com) with questions, comments or suggestions.

**ELATION SERVICE USA - Monday - Friday 8:00am to 4:30pm PST**  
323-582-3322 | Fax 323-832-9142 | [support@elationlighting.com](mailto:support@elationlighting.com)

**ELATION SERVICE EUROPE - Monday - Friday 08:30 to 17:00 CET**  
+31 45 546 85 63 | Fax +31 45 546 85 96 | [support@elationlighting.eu](mailto:support@elationlighting.eu)

**REPLACEMENT PARTS** please visit [parts.elationlighting.com](https://parts.elationlighting.com)

## **WARRANTY (USA ONLY)**

- A. This ULTIMATE WARRANTY covers the first two years of operation or 6,000 hours of use, whichever comes first, based on regular maintenance for the fixture and lamp. This comprehensive warranty for a 2-year period covers material and workmanship of the fixture, including the highly efficient Philips Platinum FLEX 200 lamp. Elation Professional warrants product rechargeable batteries to be free of manufacturing defects in material and workmanship for a period of six months (180 days) from the original date of purchase. This warranty shall be valid only if the product is purchased within the United States of America, including possessions and territories. It is the owner's responsibility to establish the date and place of purchase by acceptable evidence, at the time service is sought.
- B. For warranty service, send the product only to the Elation Professional factory. All shipping charges must be pre-paid. If the requested repairs or service (including parts replacement) are within the terms of this warranty, Elation Professional will pay return shipping charges only to a designated point within the United States. If any product is sent, it must be shipped in its original package and packaging material. No accessories should be shipped with the product. If any accessories are shipped with the product, Elation Professional shall have no liability whatsoever for loss and/or or damage to any such accessories, nor for the safe return thereof.
- C. This warranty is void if the product serial number and/or labels are altered or removed; if the product is modified in any manner which Elation Professional concludes, after inspection, affects the reliability of the product; if the product has been repaired or serviced by anyone other than the Elation Professional factory unless prior written authorization was issued to purchaser by Elation Professional; if the product is damaged because not properly maintained as set forth in the product instructions, guidelines and/or user manual.
- D. This is not a service contract, and this warranty does not include any maintenance, cleaning, or periodic check-up. During the periods as specified above, Elation Professional will replace defective parts at its expense, and will absorb all expenses for warranty service and repair labor by reason of defects in material or workmanship. The sole responsibility of Elation Professional under this warranty shall be limited to the repair of the product, or replacement thereof, including parts, at the sole discretion of Elation Professional. All products covered by this warranty were manufactured after January 1, 1990, and bare identifying marks to that effect.
- E. Elation Professional reserves the right to make changes in design and/or performance improvements upon its products without any obligation to include these changes in any products theretofore manufactured.
- F. No warranty, whether expressed or implied, is given or made with respect to any accessory supplied with the products described above. Except to the extent prohibited by applicable law, all implied warranties made by Elation Professional in connection with this product, including warranties of merchantability or fitness, are limited in duration to the warranty periods set forth above. And no warranties, whether expressed or implied, including warranties of merchantability or fitness, shall apply to this product after said periods have expired. The consumer's and/or dealer's sole remedy shall be such repair or replacement as is expressly provided above; and under no circumstances shall Elation Professional be liable for any loss and/or damage, direct and/or consequential, arising out of the use of, and/or the inability to use, this product.
- G. This warranty is the only written warranty applicable to Elation Professional products and supersedes all prior warranties and written descriptions of warranty terms and conditions heretofore published.

## **WARRANTY RETURNS**

All returned service items whether under warranty or not, must be freight pre-paid and accompany a return authorization (R.A.) number. The R.A. number must be clearly written on the outside of the return package. A brief description of the problem as well as the R.A. number must also be written down on a piece of paper and included in the shipping container. If the unit is under warranty, you must provide a copy of your proof of purchase invoice. Items returned without a R.A. number clearly marked on the outside of the package will be refused and returned at customer's expense. You may obtain a R.A. number by contacting customer support.

# SAFETY GUIDELINES

This fixture is a sophisticated piece of electronic equipment. To guarantee a smooth operation, it is important to follow all instructions and guidelines in this manual. Elation Professional is not responsible for injury and/or damages resulting from the misuse of this fixture due to the disregard of the information printed in this manual. Only qualified and/or certified personnel should perform installation of this fixture and only the original rigging parts (omega brackets) included with this fixture should be used for installation. Any modifications to the fixture and/or the included mounting hardware will void the original manufactures warranty and increase the risk of damage and/or personal injury.



## **PROTECTION CLASS 1 - FIXTURE MUST BE PROPERLY GROUNDED**

**THERE ARE NO USER SERVICEABLE PARTS INSIDE THIS UNIT. DO NOT ATTEMPT ANY REPAIRS YOURSELF; DOING SO WILL VOID YOUR MANUFACTURES WARRANTY. DAMAGES RESULTING FROM MODIFICATIONS TO THIS FIXTURE AND/OR THE DISREGARD OF SAFETY INSTRUCTIONS AND GUIDELINES IN THIS MANUAL VOID THE MANUFACTURES WARRANTY AND ARE NOT SUBJECT TO ANY WARRANTY CLAIMS AND/OR REPAIRS.**



**DO NOT PLUG FIXTURE INTO A DIMMER PACK!  
NEVER OPEN THIS FIXTURE WHILE IN USE!  
UNPLUG POWER BEFORE SERVICING FIXTURE!  
NEVER TOUCH FIXTURE DURING OPERATION, AS IT MAY BE HOT!  
KEEP FLAMMABLE MATERIALS AWAY FROM FIXTURE!**



**NEVER LOOK DIRECTLY INTO THE LIGHT SOURCE!  
RETINA INJURY RISK - MAY INDUCE BLINDNESS!  
SENSITIVE PERSONS MAY SUFFER AN EPILEPTIC SHOCK!**



**INDOOR / DRY LOCATIONS USE ONLY!  
DO NOT EXPOSE FIXTURE TO RAIN AND MOISTURE!**

**MINIMUM DISTANCE TO OBJECTS/SURFACES  
MUST BE 3.3 FEET (1.0 METER)  
MAXIMUM TEMP OF EXTERNAL SURFACE 185° F (85°C)  
MINIMUM DISTANCE OF INFLAMMABLE MATERIALS  
FROM THE SURFACE 1.6 FEET (0.5 METER)**



# SAFETY GUIDELINES

**DO NOT TOUCH** the fixture housing during operation. Turn OFF the power and allow approximately 15 minutes for the fixture to cool down before serving.

**DO NOT** shake fixture, avoid brute force when installing and/or operating fixture.

**DO NOT** operate fixture if the power cord is frayed, crimped, damaged and/or if any of the power cord connectors are damaged and do not insert into the fixture securely with ease. **NEVER** force a power cord connector into the fixture. If the power cord or any of its connectors are damaged, replace it immediately with a new one of similar power rating.

**DO NOT** block any air ventilation slots.

All fan and air inlets must remain clean and never blocked.

Allow approx. 6" (15cm) between fixture and other devices or a wall for proper cooling.

When installing fixture in a suspended environment, always use mounting hardware that is no less than M10 x 25 mm, and always install fixture with an appropriately rated safety cable.

Always disconnect fixture from main power source before performing any type of service and/or cleaning procedure. Only handle the power cord by the plug end, never pull out the plug by tugging the wire portion of the cord.

During the initial operation of this fixture, a light smoke or smell may emit from the interior of the fixture. This is a normal process and is caused by excess paint in the interior of the casing burning off from the heat associated with the lamp and will decrease gradually over time.

Consistent operational breaks will ensure fixture will function properly for many years.

## FIXTURE TRANSPORTATION

The device is a large format fixture that contains delicate optics and glass filters. While this product was carefully designed to be roadworthy, it must be handled carefully during transportation. If your fixture features color flags, ensure before transport that the color flags are placed in an OPEN position. For superior impact protection, the fixture should be shipped in a custom fitted high-density Foam Inlay (FIL). This FIL must be used inside the road-cases for transportation.

DO NOT tip the case over, and avoid all shocks and rough handling, especially “tipping”, the practice of tipping the fixture-case over to its side and onto a hard surface. The case must ride on its wheels so that the fixture-head remains horizontal during transportation.

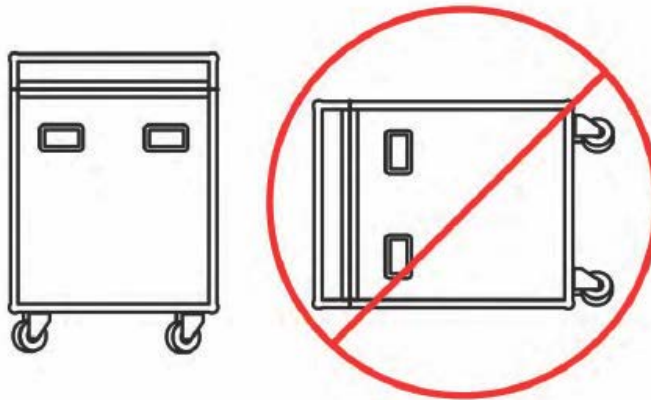



# MAINTENANCE GUIDELINES



**DISCONNECT POWER BEFORE PERFORMING ANY MAINTENANCE!**

## CLEANING

Frequent cleaning is recommended to insure proper function, optimized light output, and an extended life. The frequency of cleaning depends on the environment in which the fixture operates: damp, smoky or particularly dirty environments can cause greater accumulation of dirt on the fixture's optics. Clean the external lens surface at least every 20 days with a soft cloth to avoid dirt/debris accumulation.

**NEVER** use alcohol, solvents, or ammonia-based cleaners.

## MAINTENANCE

Regular inspections are recommended to insure proper function and extended life.

There are no user serviceable parts inside this fixture, please refer all other service issues to an authorized Elation service technician. Should you need any spare parts, please order genuine parts from your local Elation dealer.

Please refer to the following points during routine inspections:

A detailed electric check by an approved electrical engineer every three months, to make sure the circuit contacts are in good condition and prevent overheating.

Be sure all screws and fasteners are securely tightened at all times. Loose screws may fall out during normal operation resulting in damage or injury as larger parts could fall.

Check for any deformations on the housing, color lenses, rigging hardware and rigging points (ceiling, suspension, trussing). Deformations in the housing could allow for dust to enter into the fixture. Damaged rigging points or unsecured rigging could cause the fixture to fall and seriously injure a person(s).

Electric power supply cables must not show any damage, material fatigue or sediments. **NEVER** remove the ground prong from the power cable.

# FIXTURE OVERVIEW

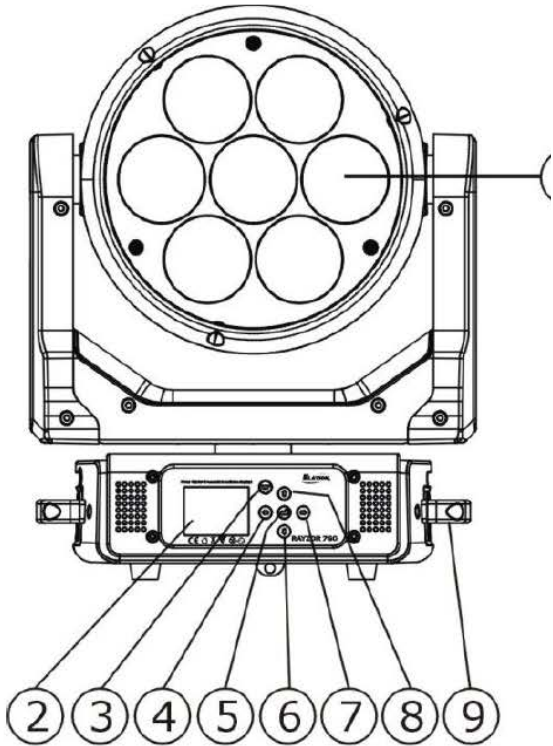

1. Lens
2. LCD Menu Function Display
3. MODE/ESC Button
4. LEFT Button
5. ENTER Button
6. DOWN Button
7. RIGHT Button
8. UP Button
9. Carrying Handle(s)

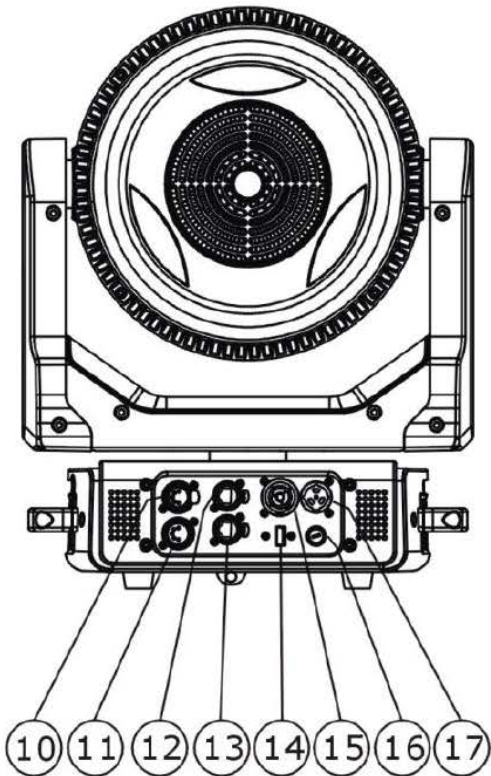

10. 5pin DMX Input
11. 5pin DMX Output
12. RJ45 Input
13. RJ45 Output
14. Service Port
15. Power Output
16. Fuse
17. Power Input

# INSTALLATION GUIDELINES



## FLAMMABLE MATERIAL WARNING

Keep fixture minimum 5.0 feet (1.5m) away from flammable materials and/or pyrotechnics.



## ELECTRICAL CONNECTIONS

A qualified electrician should be used for all electrical connections and/or installations.



**USE CAUTION WHEN POWER LINKING OTHER MODEL FIXTURES AS THE POWER CONSUMPTION OF OTHER MODEL FIXTURES MAY EXCEED THE MAX POWER OUTPUT ON THIS FIXTURE. CHECK SILK SCREEN FOR AMX AMPS.**



**MINIMUM DISTANCE TO OBJECTS/SURFACES MUST BE 3.3 FEET (1.0 METER)**



**MINIMUM DISTANCE OF INFLAMMABLE MATERIALS FROM THE SURFACE 1.6 FEET (0.5 METER)**



**MAXIMUM TEMPERATURE OF EXTERNAL SURFACE 185° F (85°C)**



**DO NOT INSTALL THE FIXTURE IF YOU ARE NOT QUALIFIED TO DO SO!**

Fixture **MUST** be installed following all local, national, and country commercial electrical and construction codes and regulations.

Before rigging/mounting a single fixture or multiple fixtures to any metal truss/structure or placing the fixture(s) on any surface, a professional equipment installer **MUST** be consulted to determine if the metal truss/structure or surface is properly certified to safely hold the combined weight of the fixture(s), clamps, cables, and accessories.

Overhead rigging requires extensive experience, including amongst others calculating working load limits, installation material being used, and periodic safety inspection of all installation material and the fixture. If you lack these qualifications, do not attempt the installation yourself. Improper installation can result in bodily injury.

Fixture ambient operating temperature range is **14° to 113°F. (-10° to 45°C)**

Do not use the fixture under or above this temperature.

Fixture(s) should be installed in areas outside walking paths, seating areas, or away from areas where unauthorized personnel might reach the fixture by hand.

**NEVER** stand directly below the fixture(s) when rigging, removing or servicing.

Overhead fixture installation must always be secured with a secondary safety attachment, such as an appropriately rated safety cable.

Allow approximately 15 minutes for the fixture to cool down before serving.

# INSTALLATION GUIDELINES

## OMEGA BRACKETS INSTALLATION

Insert the Omega Brackets into the matching holes on the bottom of the fixture. Secure the Omega Brackets to the fixture by turning each quick-lock fastener ¼ turn clockwise; making sure the fastener is completely locked. Omega Brackets can be installed into the fixture base as illustrated below.



To mount the fixture using a single clamp, install the included **Single Clamp Bracket Kit** using **ONLY** the included hardware as illustrated below.



**SINGLE CLAMP  
BRACKET**

# INSTALLATION GUIDELINES

## CLAMP INSTALLATION

When mounting fixture to truss, be sure to secure an appropriately rated professional grade rigging clamp to the included **Omega Brackets** or **Single Clamp Bracket Kit** using an M10 screw fitted through the center hole of the **Omega Brackets** or through the center hole of the **Single Clamp Bracket Kit**. The fixture provides a built-in rigging point for a **SAFETY CABLE**. Be sure to only use the designated rigging point for the safety cable and never secure a safety cable to a carrying handle.

## RIGGING

Overhead rigging requires extensive experience, including amongst others calculating working load limits, installation material being used, and periodic safety inspection of all installation material and the fixture. If you lack these qualifications, do not attempt the installation yourself. Improper installation can result in bodily injury.



**ALWAYS ATTACH AN APPROPRIATELY RATED SAFETY CABLE (NOT INCLUDED) THAT MEETS ALL LOCAL, NATIONAL, AND COUNTRY CODES AND REGULATIONS WHENEVER INSTALLING FIXTURE IN A SUSPENDED ENVIRONMENT!**



**SAFETY CABLE  
ATTACHMENT**

## POWER LINKING



**USE CAUTION WHEN POWER LINKING OTHER MODEL FIXTURES AS THE POWER CONSUMPTION OF OTHER MODEL FIXTURES MAY EXCEED THE MAX POWER OUTPUT ON THIS FIXTURE. CHECK SILK SCREEN FOR MAX AMPS.**

## ART-NET / sACN CONNECTION

When connecting fixture to a network switch to control multiple devices, a **Gigabit Ethernet Switch** that supports **IGMP (Internet Group Management Protocol)** is required. Using a **Gigabit Ethernet Switch** that does not support **IGMP** can cause erratic behavior of all connected devices to the switch. Click link below for more information about IGMP.

[https://en.wikipedia.org/wiki/Internet\\_Group\\_Management\\_Protocol](https://en.wikipedia.org/wiki/Internet_Group_Management_Protocol)

# INSTALLATION GUIDELINES

## POTENTIAL INTERNAL FIXTURE DAMAGE FROM EXTERNAL SOURCES OF LIGHT BEAMS

External sources of light beams from direct sunlight, lighting moving head fixtures, and lasers, which are focused directly on the exterior housing and/or penetrate the front lens opening of ELATION lighting fixtures, can cause severe internal damage including burning to optics, dichroic color filters, glass and metal gobos, prisms, animation wheels, frost filters, iris, shutters, motors, belts, wiring, discharge lamps, and LEDs.

This issue is not specific only to ELATION lighting fixtures, it is a common issue with lighting fixtures from all manufacturers. Although there is no true way to fully prevent this issue from happening, the guidelines below can prevent any potential damage from occurring if followed. Contact ELATION Service for more details.

**DO NOT EXPOSE THE FIXTURE AND/OR FRONT LENS OPENING TO LIGHT BEAMS FROM DIRECT SUNLIGHT, OTHER LIGHTING MOVING HEAD FIXTURES, AND LASERS WHILE UNPACKING, INSTALLATION, USE, AND EXTENDED IDLE TIMES OUTDOORS. DO NOT FOCUS A LIGHT BEAM FROM ONE LIGHTING FIXTURE DIRECTLY TOWARDS ANOTHER.**

### SUN PROTECTION MODE / HIBERNATION MODE

This state can be set via DMX, or will go into this state after 3 minutes without a DMX signal.

When the sun protection is activated, the pan-and-tilt function of the moving-head will position the lens away from direct sunlight, or other high intensity light source, to protect the internal belts, electronics etc. from burn damage.

When the unit is in the 'sun protection state', it uses its accelerometer sensors (X-Y-Z) (only present on discharge units and IP units) to position the front lens downwards, even when the unit(s) will be moved from its position. This will keep on changing the position of the head.

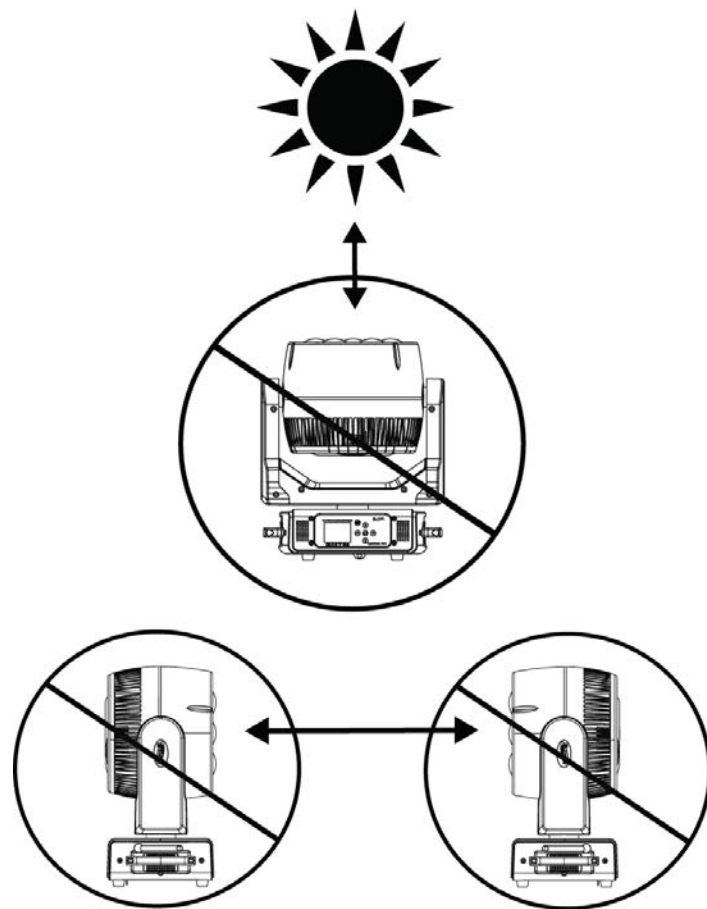

**Note that 'manual mode' overrides the 'sun-protection mode'.**

The hibernation function is an incredibly old feature that puts the unit into a 'sleep state' to save power (this is a state whereas only the electronics remain on, and all other functions are turned off, functions such as motors lamps etc.). This state is automatically activated when no DMX signal is present for the set time (1-99min or off).

# REMOTE DEVICE MANAGEMENT (RDM)

**NOTE: In order for RDM to work properly, RDM enabled equipment must be used throughout the entire system, including DMX data splitters and wireless systems.**

Remote Device Management (RDM) is a protocol that sits on top of the DMX512 data standard for lighting, allowing the DMX systems of the fixtures to be modified and monitored remotely. This protocol is ideal for instances in which a unit is installed in a location that is not easily accessible.

With RDM, the DMX512 system becomes bi-directional, allowing a compatible RDM enabled controller to send out a signal to devices on the wire, as well as allowing the fixture to respond (known as a GET command). The controller can then use its SET command to modify settings that would typically have to be changed or viewed directly via the unit's display screen, including the DMX Address, DMX Channel Mode, and Temperature Sensors.

## FIXTURE RDM INFORMATION:

Device ID	Personality ID	Model ID	RDM Code
Open	Open	1543	0x607

**Please be aware that not all RDM devices support all RDM features,** and therefore it is important to check beforehand to ensure that the equipment that you are considering includes all of the features that you require.

The following parameters are accessible in RDM on this device:

Sensor Definition
Sensor Value
Device Model Description
Manufacturer Label
Device Label
DMX Personality
DMX Personality Description
Device Hours
Pan Invert
Tilt Invert
Display Invert

# SYSTEM MENU

The fixture includes an easy to navigate system menu. The control panel (see image below) located on the front of the fixture, provides access to the main system menu and is where all necessary system adjustments are made to the fixture. During normal operation, pressing **MODE/ESC** button once will access the fixture's main menu. Once in the main menu you can navigate through the different functions and access the sub-menus with the **UP**, **DOWN**, **RIGHT**, and **LEFT** buttons. Once you reach a field that requires adjusting, press the **ENTER** button to activate that field and use the **UP** and **DOWN** buttons to adjust the field. Pressing the **ENTER** button once more will confirm your setting. You may exit the main menu at any time without making any adjustments by pressing the **MODE/ESC** button.

To access the LCD Menu Control Display via the internal battery, press and hold the **MODE/ESC** button for 3 seconds. The LCD Menu Control Display will shut **OFF** automatically about 1 minute from the last button press.

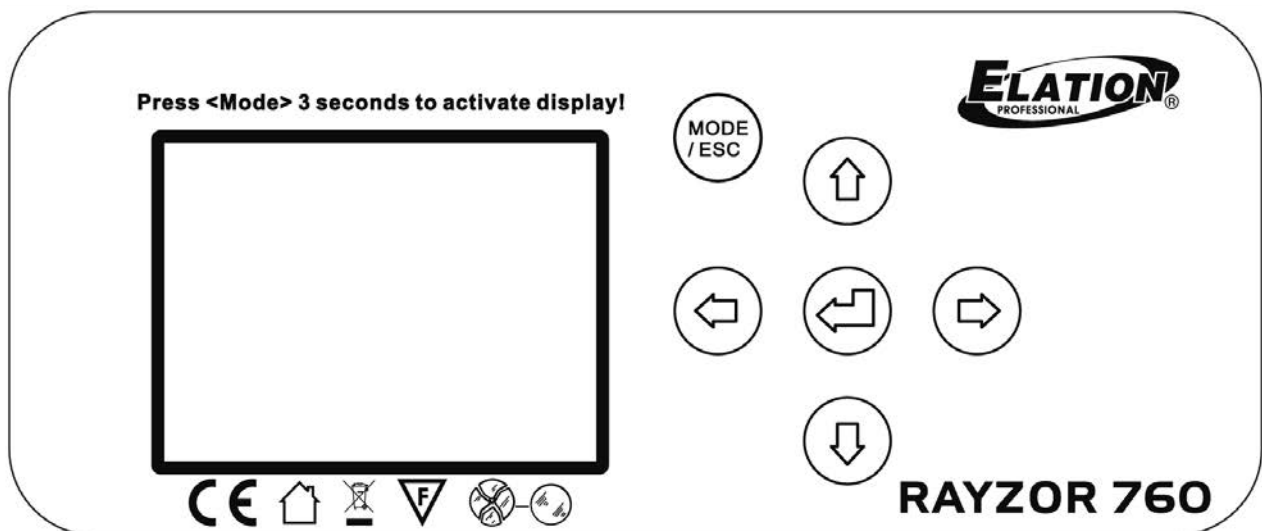



## ELATION RAYZOR 760™ SYSTEM MENU

Supports Software Versions: ≥ 1.1.1F

Features subject to change without notice.  
\*Rotation direction (Clockwise/Counterclockwise) and control of effects depends on head orientation and Pan/Tilt settings.

MAIN MENU	SUB MENU	OPTIONS / VALUES (Default Settings in <b>BOLD</b> )	DESCRIPTION
FUNCTION	Set Dmx Address	A001~AXXX	DMX Address Setting
	Dmx Value	ALL.....	DMX Value Display
	Secondary Mode	Secondary1, Secondary2, Secondary3	Secondary Setting
	Auto Program	Primary / <b>Alone</b>	Auto Program
INFORMATION	Time Information	Current Time	XXXX (Hours) Fixture Run Time From Power ON
		Total Run Time	XXXX (Hours) Fixture Total Run Time
		Last Run Time	XXXX (Hours) Fixture Last Run Time
		LastRun Password	Password= <b>038</b> <b>(PSWD Required)</b>
		Clear Last Run	ON / <b>OFF</b> Clear Fixture Last Run Time
	Temperature Info	Head Temperature	XXX C° / F° Temperature in Fixture Head
		Base Temperature	XXX C° / F° Temperature in Fixture Base
	Ethernet IP	000.000.000.000 000.000.000.000	Displays Fixture Ethernet Address
	Fan Info	HeadFan1-6, BaseFan1 / 2 (Standby, Fault)	RPM Speeds of Head/Base Fans
	Software Version	1U01... ≥ <b>V1.1.1F</b>	Software Version
Error Info	Error Record 1 ~ Error Record 10	Fixture Last 10 Error Codes	
PERSONALITY	Status Settings	Address via DMX	<b>ON/OFF</b> Address Via DMX
		No DMX Status	Close / <b>Hold</b> / Auto Fixture State When NO DMX Signal
		Pan Reverse	ON/ <b>OFF</b> Pan Reverse Movement
		Tilt Reverse	ON/ <b>OFF</b> Tilt Reverse Movement
		Pan Degree	540/ <b>360</b> Pan Degree Select
		Tilt Degree	270/ <b>360</b> Tilt Degree Select
		PanTiltPath	<b>ShortestPath</b> / ContinuePath Pan Tilt Path Mode
		Feedback	<b>ON/OFF</b> Movement Feedback
		LED Degree Change	<b>0</b> / 180 LED Degree Change
		Hibernation	OFF, 01M~99M, <b>15M</b> Stand By Mode
	Service Setting	Password	Password= <b>050</b> Service Password
		Clear Err. Info	ON/ <b>OFF</b> Clear Error Info <b>(PSWD Required)</b>
		USB Update	YES/ <b>NO</b> Service Port - Software Updates
	Fans Control	<b>Auto</b> , High, Silent	Select Fan Speeds
	Display Setting	Shutoff Time	02~60m <b>05m</b> Display Shut Off Time
		Display Reverse	ON/ <b>OFF</b> Display Reverse 180°
		Key Lock	ON/ <b>OFF</b> Key Lock
	Temperature C/F	Celsius/ <b>Fahren</b>	Temperature Switch Between C°/ F°
	Initial Status	PAN =XXX	Initial Effect Position
	Select Signal	<b>DMX Only</b>	DMX In/Out
		Art-Net	Select Art-Net
		sACN	Activate sACN
	Ethernet IP	000.000.000.000	Ethernet IP (PSWD Required)
	Ether Mask IP	000.000.000.000	Ethernet Mask IP (PSWD Required)
	Set Universe	<b>000</b> - 32767	Set Art-Net Universe
	Dimmer Mode	<b>Standard</b> , Stage, TV, Architectural, Theatre, Stage2	Set Dimmer Mode
	Refresh	<b>1200</b> , 900-1500, 2500, 4000, 5000, 10000, 15000, 20000, 25000 (Hz)	Set LED Refresh Rate
	Dimmer Curve	<b>Linear</b> , Square, Inverse Square, S-Curve	Set Dimmer Curve Mode
	Reset Default	ON/ <b>OFF</b> Password= <b>011</b>	Restore Factory Settings <b>(PSWD Required)</b>

## ELATION RAYZOR 760™ SYSTEM MENU

**Supports Software Versions: ≥ 1.1.1F**

Features subject to change without notice.  
\*Rotation direction (Clockwise/Counterclockwise) and control of effects depends on head orientation and Pan/Tilt settings.

MAIN MENU	SUB MENU	OPTIONS / VALUES (Default Settings in <b>BOLD</b> )	DESCRIPTION	
Reset Function	Reset All		Reset All Motors	
	Reset Pan&Tilt		Reset Pan/Tilt	
	Reset Others		Reset Other Motors	
Effect Adjust	Test Channel	PAN .....	Test function	
	Manual Control	PAN =XXX, .....	Fine Adjustments	
	Calibration	Calibration Password	Password <b>050 (PSWD Required)</b>	
User Mode Set	User Mode	<b>Standard</b>	DMX Channel Modes	
		Pixels		
		Extended		
Edit Program	Select Program	Auto Pro Part1 = Program 1~10 ( <b>Program 1</b> )	Select Programs To Be Run	
		Auto Pro Part2 = Program 1~10 ( <b>Program 2</b> )		
		Auto Pro Part3 = Program 1~10 ( <b>Program 3</b> )		
	Edit Program	Program 1	Program Test	Testing Program
		:	Step 01=SCxxx	Program In Loop
		Program 10	Step 64=SCxxx	Save and Exit
	Edit Scenes	Edit Scene 001 ~ Edit Scene 250	Pan,Tilt,.....	Save and Automatically Return
			--Fade Time-- --Scene Time--	Manual Scenes Edit
			Input By Outside	Stores Scenes via Ext DMX Console
Rec. Controller		XX~XX	Automatic Scenes Recorder	

### REVISED SUB MENUS WITH SOFTWARE UPDATE VERSION ≥1.1.1

See highlighted menu items below which have been updated with this software update.

PERSONALITY	Service Setting	Password	Password= <b>050</b>	Service Password
		RDM UID	<b>22A6xxxxxxxx</b>	RDM UID Code ( <b>PSWD Required</b> )
		Clear Err. Info	<b>ON/OFF</b>	Clear Error Info ( <b>PSWD Required</b> )
		USB Update	<b>YES/NO</b>	Service Port - Software Updates
	Dimmer Mode	<b>Standard</b> , Stage, TV, Architectural, Theatre, Stage2, 0.0, 0.1, 0.2, 0.3, 0.4, 0.5, 0.6, 0.7, 0.8, 0.9, 1.0, 1.5, 2.0, 2.5, 3.0, 4.0, 5.0, 6.0, 7.0, 8.0, 9.0, 10.0		Set Dimmer Mode / Delay Time

**ELATION RAYZOR 760™  
SYSTEM MENU**

**Supports Software Versions: ≥ 1.3**

Features subject to change without notice.  
\*Rotation direction (Clockwise/Counterclockwise) and control of effects depends on head orientation and Pan/Tilt settings.

MAIN MENU	SUB MENU	OPTIONS / VALUES (Default Settings in <b>BOLD</b> )		DESCRIPTION
FUNCTION	Set Dmx Address	A001~AXXX		DMX Address Setting
	Dmx Value	ALL.....		DMX Value Display
	Secondary Mode	Secondary1, Secondary2, Secondary3		Secondary Setting
	Auto Program	Primary / <b>Alone</b>		Auto Program
INFORMATION	Time Information	Current Time	XXXX (Hours)	Fixture Run Time From Power ON
		Total Run Time	XXXX (Hours)	Fixture Total Run Time
		Last Run Time	XXXX (Hours)	Fixture Last Run Time
		LastRun Password	Password= <b>038</b>	<b>(PSWD Required)</b>
		Clear Last Run	ON / <b>OFF</b>	Clear Fixture Last Run Time
	Temperature Info	Head Temperature	XXX C° / F°	Temperature in Fixture Head
		Base Temperature	XXX C° / F°	Temperature in Fixture Base
	Ethernet IP	000.000.000.000	000.000.000.000	Displays Fixture Ethernet Address
	Fan Info	HeadFan1: xxxx RPM ...		RPM Speeds of Head/Base Fans
	Software Version	Vx.xx		Software Version
Error Info	Error Record 1 ~ Error Record 10		Fixture Last 10 Error Codes	
PERSONALITY	Status Settings	Address via DMX	<b>ON/OFF</b>	Address Via DMX
		No DMX Status	Close / <b>Hold</b> / Auto	Fixture State When NO DMX Signal
		Pan Reverse	<b>ON/OFF</b>	Pan Reverse Movement
		Tilt Reverse	<b>ON/OFF</b>	Tilt Reverse Movement
		Pan Degree	540/ <b>360</b>	Pan Degree Select
		Tilt Degree	270/ <b>360</b>	Tilt Degree Select
		PanTiltPath	ShortestPath / <b>ContinuePath</b>	Pan Tilt Path Mode
		Feedback	<b>ON/OFF</b>	Movement Feedback
		LED Degree Change	<b>0</b> / 180	LED Degree Change
		Hibernation	OFF, 01M~99M, <b>15M</b>	Stand By Mode
	Service Setting	Password	Password= <b>050</b>	Service Password
		Clear Err. Info	<b>ON/OFF</b>	Clear Error Info ( <b>PSWD Required</b> )
		USB Update	YES/ <b>NO</b>	Service Port - Software Updates
	Fans Control	<b>Auto</b> , High, Silent		Select Fan Speeds
	Display Setting	Shutoff Time	02~60m <b>05m</b>	Display Shut Off Time
		Display Reverse	<b>ON/OFF</b>	Display Reverse 180°
		Key Lock	<b>ON/OFF</b>	Key Lock
	Temperature C/F	<b>Celsius/Fahren</b>		Temperature Switch Between C°/ F°
	Initial Status	PAN =XXX		Initial Effect Position
	Select Signal	<b>DMX Only</b>		DMX In/Out
		Art-Net		Select Art-Net
		sACN		Activate sACN
	Klingnet	On / Off		Auto assign IP address
	Ethernet IP	000.000.000.000		Ethernet IP ( <b>PSWD Required</b> )
	Ether Mask IP	000.000.000.000		Ethernet Mask IP ( <b>PSWD Required</b> )
	Set Universe	<b>000</b> - 32767		Set Art-Net Universe
	DHCP	On / Off		
	Dimmer Mode	<b>Standard</b> , Stage, TV, Architectural, Theatre, Stage2, 0s to 10s		Set Dimmer Mode
	Refresh	<b>1200</b> , 900-1500, 2500, 4000, 5000, 10000, 15000, 20000, 25000 (Hz)		Set LED Refresh Rate
	Dimmer Curve	<b>Linear</b> , Square, Inverse Square, S-Curve		Set Dimmer Curve Mode
Reset Default	<b>ON/OFF</b>	Password= <b>011</b>	Restore Factory Settings ( <b>PSWD Required</b> )	

MAIN MENU	SUB MENU	OPTIONS / VALUES (Default Settings in <b>BOLD</b> )		DESCRIPTION
Reset Function	Reset All			Reset All Motors
	Reset Pan&Tilt			Reset Pan/Tilt
	Reset Others			Reset Other Motors
Effect Adjust	Test Channel	PAN .....		Test function
	Manual Control	PAN =XXX, .....		Fine Adjustments
	Calibration	Calibration Password	PAN = XXX, ...	Password <b>050 (PSWD Required)</b>
User Mode Set	User Mode	<b>Standard</b>		DMX Channel Modes
		Pixels		
		Extended		
Edit Program	Select Program	Auto Pro Part1 = Program 1~10 ( <b>Program 1</b> )		Select Programs To Be Run
		Auto Pro Part2 = Program 1~10 ( <b>Program 2</b> )		
		Auto Pro Part3 = Program 1~10 ( <b>Program 3</b> )		
	Edit Program	Program 1	Program Test	Testing Program
		:	Step 01=SCxxx	Program In Loop
		Program 10	Step 64=SCxxx	Save and Exit
	Edit Scenes	Edit Scene 001 ~ Edit Scene 250	Pan,Tilt,.....	Save and Automatically Return
			--Fade Time-- --Scene Time--	Manual Scenes Edit
			Input By Out	Stores Scenes via Ext DMX Console
Rec. Controller	XX~XX	Automatic Scenes Recorder		

# SYSTEM MENU

## PERSONALITY - Status Settings - Address Via DMX

When ON, define the desired DMX address via an external controller.

**NOTE:** This process assumes the fixture DMX address is set to 001. If fixture DMX address is not at 001, you must adjust the channel numbers accordingly in order for this feature to work.

**For example:** if your fixture address is 010, then Channel 1 becomes Channel 10, Channel 2 becomes Channel 11, and Channel 3 becomes Channel 12.

1. Connect the fixture to the external controller and power ON.
2. Set the DMX value of **Channel 1** on the controller to **(7)**.
3. Set the DMX value of **Channel 2** on the controller to **(7)** or **(8)**.  
When set to **(7)**, the DMX address can be set between **(1)** and **(255)**.  
When set to **(8)**, the DMX address can be set between **(256)** and **(511)**.
4. Using **Channel 3** on the controller set the desired DMX address of the fixture.  
**Example 1:** If the desired DMX address is **57**, set **Channel 1** to a value of **(7)**, set **Channel 2** to a value of **(7)**, and then set **Channel 3** to a value of **(57)**.  
**Example 2:** If the desired DMX address is **420**, set **Channel 1** to a value of **(7)**, set **Channel 2** to a value of **(8)**, and then set **Channel 3** to a value of **(164)**. ( $256+164=420$ )
5. After setting **Channel 3** to the desired DMX address value, wait for approximately 20 seconds (some fixtures may require a longer time) for the fixture to complete the address reset function.

## PERSONALITY – Service Setting - Password (050)

The Service Password MUST be entered in order to access the service menus.

# SYSTEM MENU

## PERSONALITY – Service Setting – USB Update

To update the fixture software via the **UPDATE/SERVICE PORT**, refer to the steps shown in the **Software Update** section of this manual.



**ONLY QUALIFIED TECHNICIANS SHOULD PERFORM THIS FUNCTION!**  
**NOTE ALL MENU SETTINGS BEFORE UPDATING SOFTWARE!**  
**FIXTURE SOFTWARE CAN NOT BE DOWNGRADED!**  
**DOWNLOAD FIXTURE SOFTWARE TO PC ONLY! (NO MAC SUPPORT)**  
**PLEASE CONTACT ELATION SERVICE FOR FURTHER INFORMATION.**

## PERSONALITY - Display Setting – Key Lock

When ON, Control Panel buttons lock automatically after exiting main menu for 15 seconds. To unlock, keep **MODE/ESC** button pressed for 3 seconds.

## PERSONALITY - Reset Default (011)



**ONLY QUALIFIED TECHNICIANS SHOULD PERFORM THIS FUNCTION!**  
**NOTE: SAVED WHITE BALANCE IS ERASED AFTER A RESET IS PERFORMED!**

This function restores all fixture settings to the factory default settings. The password is **011** and must be entered each time a reset is performed.

# SYSTEM MENU

## **EFFECT ADJUST – Test Channel**

Auto test each individual channel function independently from the DMX control board.

## **EFFECT ADJUST – Manual Control**

Select and manually test and fine adjust each individual channel function independently from DMX control board. This function will center PAN and TILT motors and set dimmer to 100%. PAN and TILT functions will still operate if the fixture needs to be positioned to a flat clear surface. With the individual functions, you can focus the light on a flat surface (wall) and perform fine adjustments.

## **EFFECT ADJUST – Calibration**



**ONLY QUALIFIED TECHNICIANS SHOULD PERFORM THIS FUNCTION.**

This function allows small adjustments to be made to the Pan, Tilt, and Zoom movements to compensate for wear or in the event a sensor has been knocked slightly out of place. Because improper use of this function can result in undesired operation this function has been password protected. The password is **050** and must be entered each time the calibration menu function is entered. Because calibration is an extremely delicate procedure, instructions on performing this action are left out of this manual. For a first-time calibrator, please contact our customer support team for step-by-step instructions.

## **EDIT PROGRAM – Rec. Controller**

The fixture features an integrated DMX-recorder by which you can transmit the programmed scenes from your DMX-controller to the moving head. Adjust the desired scene numbers via the encoder (from – to). When you call up the scenes at your controller, they will automatically be transmitted to the moving head.

# SYSTEM MENU

## EDIT PROGRAM – Record Controller – Working with Built-In Programs

A Primary unit can send up to 3 different data groups to the Secondary units, i.e. a Primary unit can start 3 different Secondary units, which run 3 different programs. The Primary unit sends the 3 program parts in a continuous loop.

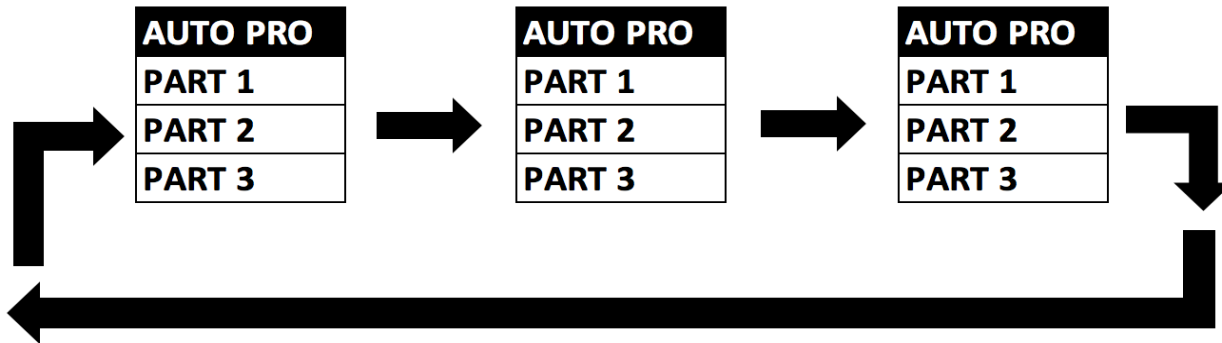

The Secondary unit receives data from the Primary unit according to the group which the Secondary unit was assigned to. If e.g. a Secondary unit is set to “**Secondary 1**” in the menu “**Set to Secondary**”, the Primary unit sends “**Auto Program Part 1**” to the Secondary unit.

If set to “**Secondary 2**”, the Secondary unit receives “**Auto Program Part 2**”.

To start an Auto Program, proceed as follows:

### 1. Secondary Setting

Select “**Function Mode**”.

Press **ENTER** to confirm.

Select “**Set to Secondary**”.

Press **ENTER** to confirm.

Select “**Secondary 1**”, “**Secondary 2**” or “**Secondary 3**”.

Press **ENTER** to confirm.

Press **MODE/ESC** in order to return to the main menu.

### 2. Automatic Program Run

Select “**Function Mode**”.

Press **ENTER** to confirm.

Select “**Auto Program**”.

Press **ENTER** to confirm.

Select “**Primary**” or “**Alone**”.

Press **ENTER** to confirm.

Press **MODE/ESC** in order to return to the main menu.



# SYSTEM MENU

## EDIT PROGRAM – Record Controller – Working with Built-In Program [continued]

### 3. Program Selection for Auto Pro Part

Select “**Edit Program**”.

Press **ENTER** to confirm.

Select “**Select Programs**”.

Press **ENTER** to confirm.

Select “**Auto Pro Part 1**”, “**Auto Pro Part 2**” or “**Auto Pro Part 3**” and select which Secondary program is to be sent. Selection “**Part 1**” means, that the Secondary unit runs the same program as the Primary units.

Press **ENTER** to confirm.

Press **MODE/ESC** in order to return to the main menu.

### 4. Program Selection for Edit Program

Select “**Edit Program**”.

Press **ENTER** to confirm.

Select “**Edit Program**”.

Press **ENTER** to confirm.

Select the desired program to edit specific scenes into a specific program.

Press **ENTER** to confirm.

Press **MODE/ESC** in order to return to the main menu.

### 5. Automatic Scene Recording

Select “**Edit Program**”.

Press **ENTER** to confirm.

Select “**Edit Scenes**”.

Select desired scene numbers. A maximum of 250 scenes can be programmed.

Press **ENTER** to confirm.

Press **MODE/ESC** in order to return to the main menu.

#### Example:

Program 2 includes scenes: 10, 11, 12, & 13

Program 4 includes scenes: 8, 9, & 10

Program 6 includes scenes: 12, 13, 14, & 15

Auto Pro Part 1 is Program 2

Auto Pro Part 2 is Program 3

Auto Pro Part 3 is Program 6

The 3 Secondary groups run the Auto Program in certain time segments. (See chart below)

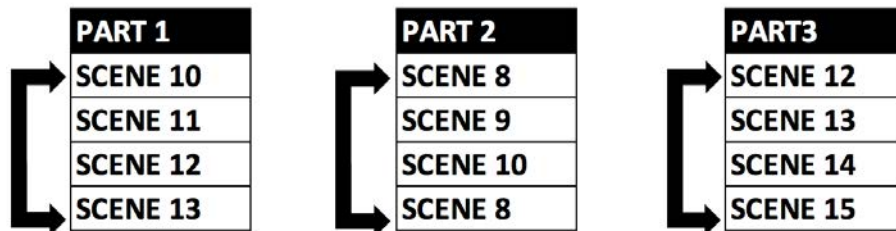

# FAN CONTROL

The Rayzor 760 is a high-performance fixture suited for multiple applications. For noise critical environments such as Theater, Opera, or Orchestral Halls, it offers various fan operation modes which remove unwanted noise distractions for the audience and performers. Fan Modes can be changed remotely via the DMX control channel, allowing the fixture to offer high output or whisper-silent operation at a moment's notice. All Fan Modes smoothly transition over a brief period, preventing unwanted attraction to the fixture.

**Auto (Default)** – Fans only run at the speeds needed to keep the LED engine within a safe temperature range, and ensures optimal performance of the fixture. They will turn off if possible; for example, when the fixture is dimmed to a low intensity. Fans sense the ambient and fixture temperature and will, at all times, try to keep noise levels at a minimum. The fixture output will only be reduced when the LED engine cannot be cooled to its safe operating range due to a high ambient temperature.

***NOTE: This mode is recommended for daily operation.***

**Silent** – Fan speeds are reduced throughout the fixture for a lower noise profile. The fixture output is also reduced to approximately 80%. This mode should be sufficient for most uses where lower noise is required.

**High** – Fan speeds are increased throughout the fixture for the most efficient cooling. This mode will increase wear on the fans and should only be utilized in exceptional circumstances. Fans will always run, even if the fixture is dimmed. Fixture output is kept at 100% unless the LED engine temperature reaches an unsafe temperature, at which point the fixture will reduce power carefully to ensure continued safe operation. This mode is only required in very high ambient temperatures when automatic fan speed adjustments are not desired.

# LIGHTING CONSOLE PATCHING GUIDELINES

The RAYZOR 760 is a versatile luminaire which combines two fixtures into one housing, allowing it to produce multiple unique lighting effects typically not found in a single lighting fixture. The DMX layout is designed to offer a variety of options for controlling each fixture efficiently.

The main fixture contains 7x 60W RGBW pixel cells, while the SparkLED fixture contains 28 x 2W white LEDs. For ease of use the DMX layout is arranged to allow lighting consoles to separate the fixture into multiple segments or parts. It is important to arrange the fixture in such segments or parts especially when using the fixture in the full extended 80 channel DMX mode. For simpler programming, reduced DMX channel modes can be used. However, for easy recall of interesting pixel animations both the RGBW and SparkLED fixtures contain two FX systems, one controls the RGBW cells, while the other is dedicated to the SparkLEDs.

The pixels are arranged in a grid pattern as illustrated below. (RGBW 1-7 | SparkLED 1-28)

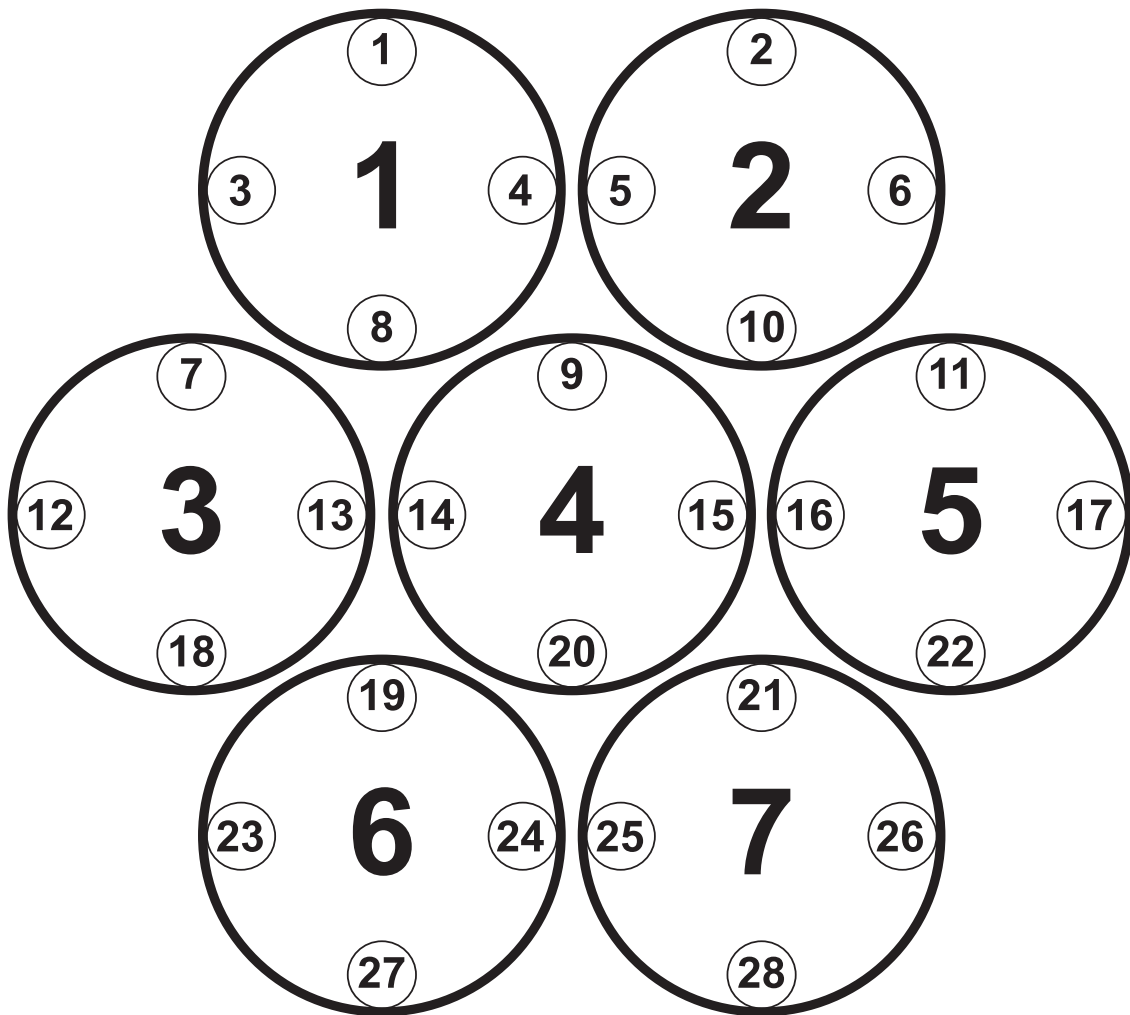

# LIGHTING CONSOLE PATCHING GUIDELINES

<b>PIXEL LAYOUT</b>	<b>PIXEL NUMBERS</b>
<b>RGBW Row 1</b>	1, 2
<b>RGBW Row 2</b>	3, 4, 5
<b>RGBW Row 3</b>	6, 7
<b>RGBW Column 1</b>	3
<b>RGBW Column 2</b>	1, 3, 6
<b>RGBW Column 3</b>	1, 4, 6,
<b>RGBW Column 4</b>	4
<b>RGBW Column 5</b>	2, 4, 7
<b>RGBW Column 6</b>	2, 5, 7
<b>RGBW Column 7</b>	5
<b>SparkLED Row 1</b>	1, 2
<b>SparkLED Row 2</b>	3, 4, 5, 6
<b>SparkLED Row 3</b>	7, 8, 9, 10, 11
<b>SparkLED Row 4</b>	12, 13, 14, 15, 16, 17
<b>SparkLED Row 5</b>	18, 19, 20, 21, 22
<b>SparkLED Row 6</b>	23, 24, 25, 26
<b>SparkLED Row 7</b>	27, 28
<b>SparkLED Ring 1</b>	1, 2, 6, 11, 17, 22, 26, 28, 27, 23, 18, 12, 7, 3
<b>SparkLED Ring 2</b>	4, 5, 10, 16, 21, 25, 24, 19, 13, 8
<b>SparkLED Ring 3</b>	9, 15, 20, 14

# LIGHTING CONSOLE PATCH GUIDELINES

There are also two additional parts for a Primary control of the RAYZOR 760, which creates four separate control areas for the fixture. It is recommended to create fixture groups on the lighting controller for each area of the fixture. (see below)

<b>Main Fixture</b>	Primary Pan, Tilt, RGBW Color, Strobe, Dimmer, Zoom, FX Controls
<b>RGBW Cells 1-7</b>	Red, Green, Blue, White per each individual cell
<b>SparkLED Main</b>	Primary SparkLED Strobe, Dimmer
<b>SparkLEDs 1-28</b>	SparkLED Dimmer per each individual LED

➔ **SparkLED is not available as a mode in the fixture menu but must be provided as a console control profile for easy programming of the fixture. Use the RAYZOR 760 in Extended mode and patch appropriate parts of the RGBW Pixels and SparkLED fixtures on your control system to access all 80 channels.**

On the lighting controller, patch the two fixture types (RGBW and SparkLED), separating the SparkLEDs into a different ID range. (see below)

## RGBW Pixels for Channels 1-52

## SparkLEDs for Channels 53-80

**ONYX** Main and Sub Fixture ID patch example below for a single RAYZOR 760 fixture.

ID	Type	Address
1.0	RGBW Pixels Main	1
1.1	Pixel 1	22
1.2	Pixel 2	26
1.3	Pixel 3	30
1.4	Pixel 4	34
1.5	Pixel 5	38
1.6	Pixel 6	42
1.7	Pixel 7	46
1.8	SparkLED Main	50

101.1	SparkLED 1	53
101.2	SparkLED 2	54
101.3	SparkLED 3	55
101.4	SparkLED 4	56
...	...	...
101.28	SparkLED 28	80

# LIGHTING CONSOLE PATCH GUIDELINES

**ONLYX** screen shots below illustrate Main and Sub Fixture ID patch for a single RAYZOR 760 fixture.

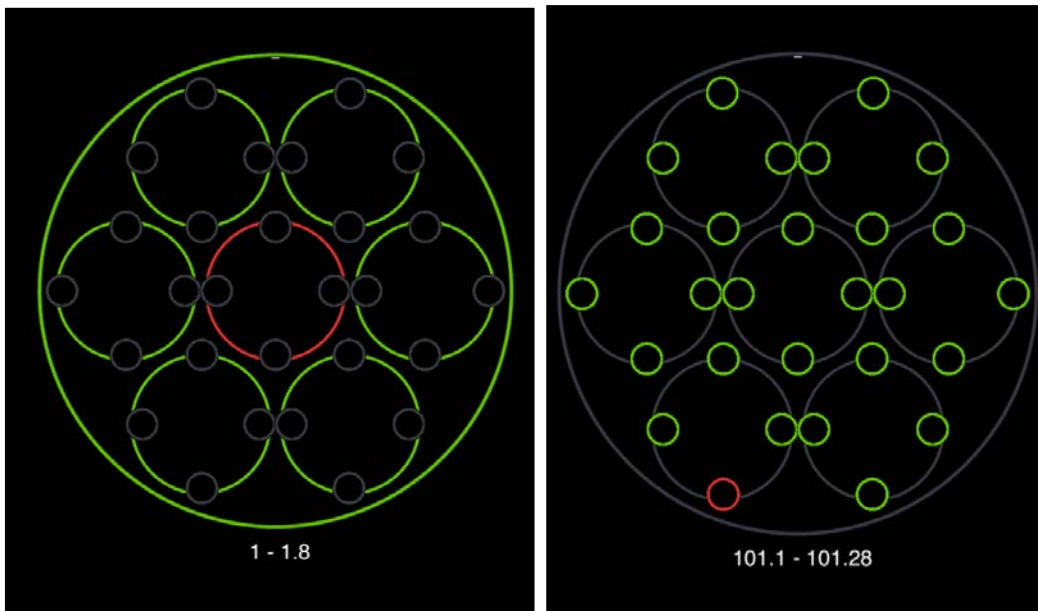

← Back

Tasks

- Patch
- Cloning
- Swap
- RDM

ID	Name	Type	Universe	Address	Invert
1		Rayzor 760 Pixel (Master)	1	1	
1.1		Rayzor 760 Pixel (Pixel 1)	Auto	Auto	
1.2		Rayzor 760 Pixel (Pixel 2)	Auto	Auto	
1.3		Rayzor 760 Pixel (Pixel 3)	Auto	Auto	
1.4		Rayzor 760 Pixel (Pixel 4)	Auto	Auto	
1.5		Rayzor 760 Pixel (Pixel 5)	Auto	Auto	
1.6		Rayzor 760 Pixel (Pixel 6)	Auto	Auto	
1.7		Rayzor 760 Pixel (Pixel 7)	Auto	Auto	
1.8		Rayzor 760 Pixel (SparkLED)	Auto	Auto	

ID	Name	Type	Universe	Address	Invert
101		Rayzor 760 SparkLED	1	51	
101.1		Rayzor 760 SparkLED (LED 1)	Auto	Auto	
101.2		Rayzor 760 SparkLED (LED 2)	Auto	Auto	
101.3		Rayzor 760 SparkLED (LED 3)	Auto	Auto	
101.4		Rayzor 760 SparkLED (LED 4)	Auto	Auto	
101.5		Rayzor 760 SparkLED (LED 5)	Auto	Auto	
101.6		Rayzor 760 SparkLED (LED 6)	Auto	Auto	
101.7		Rayzor 760 SparkLED (LED 7)	Auto	Auto	
101.8		Rayzor 760 SparkLED (LED 8)	Auto	Auto	
101.9		Rayzor 760 SparkLED (LED 9)	Auto	Auto	
101.10		Rayzor 760 SparkLED (LED 10)	Auto	Auto	
101.11		Rayzor 760 SparkLED (LED 11)	Auto	Auto	
101.12		Rayzor 760 SparkLED (LED 12)	Auto	Auto	
101.13		Rayzor 760 SparkLED (LED 13)	Auto	Auto	
101.14		Rayzor 760 SparkLED (LED 14)	Auto	Auto	
101.15		Rayzor 760 SparkLED (LED 15)	Auto	Auto	
101.16		Rayzor 760 SparkLED (LED 16)	Auto	Auto	
101.17		Rayzor 760 SparkLED (LED 17)	Auto	Auto	
101.18		Rayzor 760 SparkLED (LED 18)	Auto	Auto	
101.19		Rayzor 760 SparkLED (LED 19)	Auto	Auto	
101.20		Rayzor 760 SparkLED (LED 20)	Auto	Auto	
101.21		Rayzor 760 SparkLED (LED 21)	Auto	Auto	
101.22		Rayzor 760 SparkLED (LED 22)	Auto	Auto	
101.23		Rayzor 760 SparkLED (LED 23)	Auto	Auto	
101.24		Rayzor 760 SparkLED (LED 24)	Auto	Auto	
101.25		Rayzor 760 SparkLED (LED 25)	Auto	Auto	
101.26		Rayzor 760 SparkLED (LED 26)	Auto	Auto	
101.27		Rayzor 760 SparkLED (LED 27)	Auto	Auto	
101.28		Rayzor 760 SparkLED (LED 28)	Auto	Auto	

Multi Select  OFF

Change Color Change

Filter

- All fixture types 2
- Rayzor 760 Pixel 1
- Rayzor 760 SparkLED 1

# LIGHTING CONSOLE PATCH GUIDELINES

**ONYX** Groups example below for easier selection of a single RAYZOR 760 fixture.

Group Name	Group Content
All RGBW Pixels Main	1
All RGBW Pixels	1.1, 1.2, 1.3 ... 1.8
All SparkLEDs Main	1.8
All SparkLEDs	101.1 ,101.2 ... 101.28

**ONYX** screen shot below illustrates Groups for a single RAYZOR 760 fixture.



# DMX CHANNEL FUNCTIONS AND VALUES

## ELATION PROTEUS RAYZOR 760™

### DMX Channel Values / Functions (80 Total DMX Channels)

**Supports Software Versions: ≥ 1.1.1F**

Features subject to change without notice.

\*Rotation direction (Clockwise/Counterclockwise) and control of effects depends on head orientation and Pan/Tilt settings.

Standard	Pixels	Extended		Value	Function	Fade Status	Default Value
<b>Main Fixture Control</b>							
1	1	1			<b>PAN</b>	Fade	127
				0-255	Movement		
2	2	2			<b>PAN FINE</b>	Fade	127
				0-255	Fine Movement		
3	3	3			<b>TILT</b>	Fade	127
				0-255	Movement		
4	4	4			<b>TILT FINE</b>	Fade	127
				0-255	Fine Movement		
5	5	5			<b>PAN ROTATE</b>	Fade	0
				0-2	Disabled		
				3-126	Rotating CW Fast to Slow		
				127-129	NO Rotation (Fixture stops at its current position)		
				130-253	Rotating CCW Slow to Fast		
6	6	6			<b>PAN ROTATE</b>	Fade	0
			0-2	Disabled			
			3-126	Rotating CW Fast to Slow			
			127-129	NO Rotation (Fixture stops at its current position)			
			130-253	Rotating CCW Slow to Fast			
7	7	7		<b>TILT ROTATE</b>	Fade	0	
			0-2	Disabled			
			3-126	Rotating CW Fast to Slow			
			127-129	NO Rotation (Fixture stops at its current position)			
				<b>CTC</b>	Fade	0	
			0-10	Disabled			
			11-171	Color Temperature (100K Steps) 2,000K to 10,000K ( <b>See CTC Table</b> )			
				172-255	10,000K		



Standard	Pixels	Extended		Value	Function	Fade Status	Default Value
8	8	8			<b>COLOR WHEEL</b>	Snap	0
				0-9	Open		
				10-14	Red		
				15-19	Red Orange		
				20-24	Light Amber		
				25-29	Yellow Amber		
				30-34	Greenish Yellow		
				35-39	Light Yellow Green		
				40-44	Dark Yellow Green		
				45-49	Green		
				50-54	Teal		
				55-59	Cyan		
				60-64	Light Blue		
				65-69	Aqua		
				70-74	Dark Aqua		
				75-79	Green Blue		
				80-84	Light Lavender		
				85-89	Dark Purple		
				90-94	Medium Purple		
				95-99	Mid Rose		
				100-104	Mauve		
				105-109	Nice Magenta		
				110-114	Warm Magenta		
				115-119	Light Red		
				120-124	Straw		
				125-129	Dark CTB		
				130-134	Light Green		
				135-139	Purple		
				140-144	Lighter Purple		
				145-149	Pink		
				150-154	Rose		
				155-159	White		
160-164	TBD						
165-169	TBD						
170-174	TBD						
175-179	Open						
	<b>COLOR SCROLL</b>						
180-201	CW Fast to Slow						
202-207	Stop						
208-229	CCW Slow to Fast						
230-234	Open						
	<b>RANDOM SLOTS</b>						
235-239	Fast						
240-244	Medium						
245-249	Slow						
250-255	Open						

Standard	Pixels	Extended		Value	Function	Fade Status	Default Value
9	9	9			<b>STROBE</b>	Snap	50
				0-31	Shutter Closed		
				32-63	Shutter Open		
				64-95	Strobe Slow to Fast		
				96-127	Fast Close, Slow Open		
				128-159	Fast Open, Slow Close		
				160-191	Pulse Effects		
				192-223	Random Strobe Slow to Fast		
				224-255	Shutter Open		
10	10	10		<b>DIMMER</b>	Fade	0	
				0-255	0 → 100%		
11	11	11		<b>DIMMER FINE</b>	Fade	0	
				0-255	Fine Dimming		
12	12	12			<b>DIM MODES</b>	Snap	0
				0-20	Standard		
				21-40	Stage		
				41-60	TV		
				61-80	Architectural		
				81-100	Theatre		
				101-120	Stage 2		
					<b>DIMMER DELAY TIME</b>		
				121	0s		
				122	0.1s		
				123	0.2s		
				124	0.3s		
				125	0.4s		
				126	0.5s		
				127	0.6s		
				128	0.7s		
				129	0.8s		
				130	0.9s		
				131	1.0s		
				132	1.5s		
				133	2.0s		
				134	3.0s		
				135	4.0s		
				136	5.0s		
				137	6.0s		
				138	7.0s		
				139	8.0s		
				140	9.0s		
141	10s						
142-255	Idle						

Standard	Pixels	Extended		Value	Function	Fade Status	Default Value
13	13	13			<b>ZOOM</b>	Fade	128
				0 -215	Zoom Wide to Narrow		
				216-255	Overdrive Min to Max		
13	13	13			<b>UPDATED WITH SOFTWARE UPDATE VERSION 1.3</b>	Fade	0
					<b>ZOOM</b>		
				0-245	Zoom Wide to Narrow		
				246-255	Overdrive Min to Max		
	14	14			<b>ZOOM FINE</b>	Fade	0
			0-255	Fine Zoom			
	15	15			<b>PAN / TILT SPEED</b>	Snap	0
			0-225	Max to Min Speed			
			226-235	Blackout When Pan / Tilt Moves			
			236-245	Blackout When All Wheels Change			
				246-255	No Function		

Standard	Pixels	Extended		Value	Function	Fade Status	Default Value
14	16	16			<b>CONTROL</b>	Snap	0
				0-10	Idle		
				11-12	PanTilt Shortest Path		
				13-14	PanTilt Continue Path		
				15-16	Pan Range 540		
				17-18	Pan Range 360		
				19-20	Tilt Range 270		
				21-22	Tilt Range 360		
				23-39	Idle		
				40-59	Fan Mode Silent		
				60-79	Fan Mode Auto		
				80-84	Reset All		
				85-87	Reset Movement		
				88-91	Reset Zoom		
				92-100	Idle		
				100-168	Refresh Rate (Hz)		
				100	900		
				101	910		
				102	920		
				103	930		
				104	940		
				105	950		
				106	960		
				107	970		
				108	980		
				109	990		
				110	1000		
				111	1010		
				112	1020		
				113	1030		
114	1040						
115	1050						
116	1060						
117	1070						
118	1080						
119	1090						
120	1100						
121	1110						
122	1120						
123	1130						
124	1140						
125	1150						
126	1160						
127	1170						
128	1180						
129	1190						
	130	1200					

Standard	Pixels	Extended		Value	Function	Fade Status	Default Value
14	16	16			<b>CONTROL</b>	Snap	0
				131	1210		
				132	1220		
				133	1230		
				134	1240		
				135	1250		
				136	1260		
				137	1270		
				138	1280		
				139	1290		
				140	1300		
				141	1310		
				142	1320		
				143	1330		
				144	1340		
				145	1350		
				146	1360		
				147	1370		
				148	1380		
				149	1390		
				150	1400		
				151	1410		
				152	1420		
				153	1430		
				154	1440		
				155	1450		
				156	1460		
				157	1470		
				158	1480		
				159	1490		
				160	1500		
				161	2500		
				162	4000		
				163	5000		
164	6000						
165	10000						
166	15000						
167	20000						
168	25000						

Standard	Pixels	Extended		Value	Function	Fade Status	Default Value
14	16	16		169-200	Idle	Snap	0
				<b>ADDED WITH SOFTWARE UPDATE VERSION ≥1.1.1</b>			
				169-192	Idle		
				193-194	Hibernate Off		
				195-196	Hibernate		
				197-198	Home Position Before Power Off		
				199-200	Home Position Off		
				<b>UPDATED WITH SOFTWARE UPDATE VERSION 1.3</b>			
				169-192	Idle		
				193-194	Hibernate Off		
				195-196	Hibernate		
				197-200	Idle		
				201-210	Dimmer Curve Linear (default)		
				211-220	Dimmer Curve Square		
				221-230	Dimmer Curve Inverse Square		
231-240	Dimmer Curve S-Curve						
241-255	Idle						
15	17	17		<b>RGBW FX (See Table)</b>		Snap	0
				0-255	FX Selection 1 -255		
16	18	18		<b>RGBW FX SPEED</b>		Fade	160
				0-126	Rev Fast to Slow		
				127-128	Stop		
17	19	19		<b>SparkLED FX (See Table)</b>		Snap	0
				0-255	FX Selection 1 -255		
				<b>SparkLED FX SPEED</b>			
18	20	20		0-126	Rev Fast to Slow	Fade	160
				127-128	Stop		
				129-255	Slow to Fast		
19	21	21		<b>FX OFFSET</b>		Snap	0
				0	NO Sync		
				1	Fixture Offset 10 Degree		
				2	Fixture Offset 20 Degree		
				3-34	Fixture Offset...		
				35	Fixture Offset 350 Degree		
				36	Synchronized		
				37-100	No Function		
				101-120	Random Fixtures		
121-140	Random Duration						
141-255	Random Pixels						

Standard	Pixels	Extended		Value	Function	Fade Status	Default Value
<b>RGBW Pixel Control</b>							
20	22	22			<b>Red</b>	Fade	255
				0-255	0 → 100%		
21	23	23			<b>Green</b>	Fade	255
				0-255	0 → 100%		
22	24	24			<b>Blue</b>	Fade	255
				0-255	0 → 100%		
23	25	25			<b>White</b>	Fade	255
				0-255	0 → 100%		
	26	26			<b>Red 2</b>	Fade	255
				0-255	0 → 100%		
	27	27			<b>Green 2</b>	Fade	255
				0-255	0 → 100%		
	28	28			<b>Blue 2</b>	Fade	255
				0-255	0 → 100%		
	29	29			<b>White 2</b>	Fade	255
				0-255	0 → 100%		
	30	30			<b>Red 3</b>	Fade	255
				0-255	0 → 100%		
	31	31			<b>Green 3</b>	Fade	255
				0 - 255	0 → 100%		
	32	32			<b>Blue 3</b>	Fade	255
				0-255	0 → 100%		
	33	33			<b>White 3</b>	Fade	255
				0 - 255	0 → 100%		
	34	34			<b>Red 4</b>	Fade	255
				0-255	0 → 100%		
	35	35			<b>Green 4</b>	Fade	255
				0-255	0 → 100%		
	36	36			<b>Blue 4</b>	Fade	255
				0-255	0 → 100%		
	37	37			<b>White 4</b>	Fade	255
				0-255	0 → 100%		

Standard	Pixels	Extended		Value	Function	Fade Status	Default Value
<b>RGBW Pixel Control</b>							
	38	38			<b>Red 5</b>	Fade	255
				0-255	0 → 100%		
	39	39			<b>Green 5</b>	Fade	255
				0-255	0 → 100%		
	40	40			<b>Blue 5</b>	Fade	255
				0-255	0 → 100%		
	41	41			<b>White 5</b>	Fade	255
				0-255	0 → 100%		
	42	42			<b>Red 6</b>	Fade	255
				0-255	0 → 100%		
	43	43			<b>Green 6</b>	Fade	255
				0-255	0 → 100%		
	44	44			<b>Blue 6</b>	Fade	255
				0-255	0 → 100%		
	45	45			<b>White 6</b>	Fade	255
				0-255	0 → 100%		
	46	46			<b>Red 7</b>	Fade	255
				0-255	0 → 100%		
	47	47			<b>Green 7</b>	Fade	255
				0-255	0 → 100%		
	48	48			<b>Blue 7</b>	Fade	255
				0-255	0 → 100%		
	49	49			<b>White 7</b>	Fade	255
				0-255	0 → 100%		



Standard	Pixels	Extended	SparkLED	Value	Function	Fade Status	Default Value
<b>SparkLED Control</b>							
SparkLED is not available as a mode in the fixture menu but must be provided as a console control profile for easy programming of the fixture. Use the Rayzor 760 in Extended mode and patch appropriate parts of the RGBW Pixels and SparkLED fixtures on your control system to access all 80 channels. See the Lighting Console Patch Guidelines section for further instructions.							
24	50	50			<b>STROBE</b>	Snap	50
				0-31	Shutter CLOSED		
				32-63	Shutter OPEN		
				64-95	Strobe SLOW to FAST		
				96-127	FAST Close, SLOW Open		
				128-159	FAST Open, SLOW Close		
				160-191	Pulse Effects		
				192-223	Random Strobe ALL SLOW to FAST		
				224-254	Random Strobe Pixels SLOW to FAST		
				255	Sync Dimmer and Strobe with Main		
25	51	51			<b>DIMMER</b>	Fade	0
				0-255	0 → 100%		
	52	52			<b>DIMMER FINE</b>	Fade	0
				0-255	Fine Dimming		
		53	1		<b>SparkLED #1 Dimmer</b>	Fade	255
				0-255	0 → 100%		
		54	2		<b>SparkLED #2 Dimmer</b>	Fade	255
				0-255	0 → 100%		
		55	3		<b>SparkLED #3 Dimmer</b>	Fade	255
				0-255	0 → 100%		
		56	4		<b>SparkLED #4 Dimmer</b>	Fade	255
				0-255	0 → 100%		
		57	5		<b>SparkLED #5 Dimmer</b>	Fade	255
				0-255	0 → 100%		
		58	6		<b>SparkLED #6 Dimmer</b>	Fade	255
				0-255	0 → 100%		
		59	7		<b>SparkLED #7 Dimmer</b>	Fade	255
				0-255	0 → 100%		
		60	8		<b>SparkLED #8 Dimmer</b>	Fade	255
				0-255	0 → 100%		
		61	9		<b>SparkLED #9 Dimmer</b>	Fade	255
				0-255	0 → 100%		
		62	10		<b>SparkLED #10 Dimmer</b>	Fade	255
				0-255	0 → 100%		
		63	11		<b>SparkLED #11 Dimmer</b>	Fade	255
				0-255	0 → 100%		
		64	12		<b>SparkLED #12 Dimmer</b>	Fade	255
				0-255	0 → 100%		
		65	13		<b>SparkLED #13 Dimmer</b>	Fade	255
				0-255	0 → 100%		
		66	14		<b>SparkLED #14 Dimmer</b>	Fade	255
				0-255	0 → 100%		

Standard	Pixels	Extended	SparkLED	Value	Function	Fade Status	Default Value
<b>SparkLED Control</b>							
		67	15		<b>SparkLED #15 Dimmer</b>	Fade	255
				0-255	0 → 100%		
		68	16		<b>SparkLED #16 Dimmer</b>	Fade	255
				0-255	0 → 100%		
		69	17		<b>SparkLED #17 Dimmer</b>	Fade	255
				0-255	0 → 100%		
		70	18		<b>SparkLED #18 Dimmer</b>	Fade	255
				0-255	0 → 100%		
		71	19		<b>SparkLED #19 Dimmer</b>	Fade	255
				0-255	0 → 100%		
		72	20		<b>SparkLED #20 Dimmer</b>	Fade	255
				0-255	0 → 100%		
		73	21		<b>SparkLED #21 Dimmer</b>	Fade	255
				0-255	0 → 100%		
		74	22		<b>SparkLED #22 Dimmer</b>	Fade	255
				0-255	0 → 100%		
		75	23		<b>SparkLED #23 Dimmer</b>	Fade	255
				0-255	0 → 100%		
		76	24		<b>SparkLED #24 Dimmer</b>	Fade	255
				0-255	0 → 100%		
		77	25		<b>SparkLED #25 Dimmer</b>	Fade	255
				0-255	0 → 100%		
		78	26		<b>SparkLED #26 Dimmer</b>	Fade	255
				0-255	0 → 100%		
		79	27		<b>SparkLED #27 Dimmer</b>	Fade	255
				0-255	0 → 100%		
		80	28		<b>SparkLED #28 Dimmer</b>	Fade	255
				0-255	0 → 100%		





<b>COLOR TEMPERATURE CONTROL TABLE</b>					
<b>Color Temperature</b>	<b>DMX Value</b>	<b>Color Temperature</b>	<b>DMX Value</b>	<b>Color Temperature</b>	<b>DMX Value</b>
2000	11	4700	65	7400	119
2050	12	4750	66	7450	120
2100	13	4800	67	7500	121
2150	14	4850	68	7550	122
2200	15	4900	69	7600	123
2250	16	4950	70	7650	124
2300	17	5000	71	7700	125
2350	18	5050	72	7750	126
2400	19	5100	73	7800	127
2450	20	5150	74	7850	128
2500	21	5200	75	7900	129
2550	22	5250	76	7950	130
2600	23	5300	77	8000	131
2650	24	5350	78	8050	132
2700	25	5400	79	8100	133
2750	26	5450	80	8150	134
2800	27	5500	81	8200	135
2850	28	5550	82	8250	136
2900	29	5600	83	8300	137
2950	30	5650	84	8350	138
3000	31	5700	85	8400	139
3050	32	5750	86	8450	140
3100	33	5800	87	8500	141
3150	34	5850	88	8550	142
3200	35	5900	89	8600	143
3250	36	5950	90	8650	144
3300	37	6000	91	8700	145
3350	38	6050	92	8750	146
3400	39	6100	93	8800	147
3450	40	6150	94	8850	148
3500	41	6200	95	8900	149
3550	42	6250	96	8950	150
3600	43	6300	97	9000	151
3650	44	6350	98	9050	152
3700	45	6400	99	9100	153
3750	46	6450	100	9150	154
3800	47	6500	101	9200	155
3850	48	6550	102	9250	156
3900	49	6600	103	9300	157
3950	50	6650	104	9350	158
4000	51	6700	105	9400	159
4050	52	6750	106	9450	160
4100	53	6800	107	9500	161
4150	54	6850	108	9550	162
4200	55	6900	109	9600	163
4250	56	6950	110	9650	164
4300	57	7000	111	9700	165
4350	58	7050	112	9750	166
4400	59	7100	113	9800	167
4450	60	7150	114	9850	168
4500	61	7200	115	9900	169
4550	62	7250	116	9950	170
4600	63	7300	117	10000	171
4650	64	7350	118		

# FX GENERATOR GUIDELINES

Selection and control of the integrated FX on the RAYZOR 760 is found in the Main Fixture section. All FX are available even in the smallest DMX control modes. (see below)

Value	Function
	<b>RGBW FX (See Table)</b>
0-255	FX Selection 1 -255
	<b>RGBW FX Speed</b>
0-126	Rev Fast to Slow
127-128	Stop
129-255	Slow to Fast
	<b>SparkLED FX (See Table)</b>
0-255	FX Selection 1 -255
	<b>SparkLED FX Speed</b>
0-126	Rev Fast to Slow
127-128	Stop
129-255	Slow to Fast

FX for RGBW and SparkLED contain a selection channel to recall the desired pattern. The pattern direction and speed is then adjusted using the associated Speed channels. FX can run forward or reverse and can also be frozen at any time by using "Stop". The FX tables show the available patterns which are grouped for easier browsing. The first 10 DMX steps of the FX channel are used to change the type of curve for smooth or steppy FX. Once a curve is selected its used for all FX recalled afterwards. When programming cues for fixtures, the user must ensure to change the curve first before selecting the pattern. The fixture defaults to the Sinewave pattern after every power cycle.

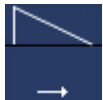
<b>Sinewave</b> (default)	
<b>Step</b>	
<b>Sawtooth</b>	
<b>Ramp Up</b>	
<b>Ramp Down</b>	

# FX GENERATOR GUIDELINES

In addition to FX direction and speed control, a Sync channel allows to offset or randomize the fixtures or the FX steps.

Value	Function
	<b>FX Offset</b>
0	NO Sync
1	Fixture Offset 10 Degree
2	Fixture Offset 20 Degree
3-34	Fixture Offset...
35	Fixture Offset 350 Degree
36	Synchronized
37-100	NO Function
101-120	Random Fixture Offset
121-140	Random Pixel Order
141-255	Random Steps

A full FX cycle is 360 degrees, and the fixture allows offsets in 10-degree increments. Offsetting a fixture by 180 would mean it is exactly halfway ahead through the FX cycle. Through individual offsets or utilizing lighting consoles fan functions the fixture allows a variety of spreads for impactful FX.

Three randomization options are provided:

## **Random Fixture Offset**

Every fixture randomly selects any of the 36 offset points. It will then use this until the offset is changed or random offset is selected again.

## **Random Pixel Order**





The actual FX steps are randomized. This shuffling of the fixture order is done once, the fixture will use this shuffled order across all FX until changed.





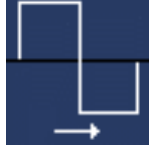

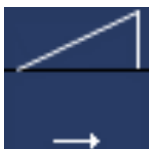
## **Random Steps**

Every step is randomly chosen every time, giving the most random looks possible.

To reshuffle the randomization set the channel to Idle and reselect the desired random option.

The FX system of the RAYZOR 760 allows many different combinations by changing the curves, offsets and speed parameters. The RGBW and SparkLED systems are separate, and by adjusting color, dimming and strobe channels there are endless creative designs possible.

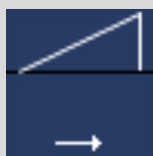
RGBW FX TABLE				
Type	Slot	DMX	Name	FX Adjustment
Waveform	0	0	OFF	
	1	1	Sinewave (default) 	
	2	2	Step 	
	3	3	Sawtooth 	
	4	4	Ramp Up 	
	5	5	Ramp Down 	
	6-10	6-10	No Function	

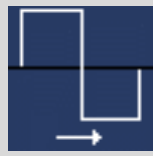



RGBW FX TABLE				
Type	Slot	DMX	Name	FX Adjustment
Waveform	REVISED WITH SOFTWARE UPDATE VERSION $\geq 1.1.1$			
	0	0	OFF	
	1	1	<b>Sinewave Cross (default)</b> 	
	2	2	<b>Sinewave Full</b> 	
	3	3	<b>Sawtooth Cross</b> 	
	4	4	<b>Sawtooth Full</b> 	
	5	5	<b>Ramp Up</b> 	
	6	6	<b>Ramp Down</b> 	
	7	7	<b>Step</b> 	
	8-10	8-10	No Function	







RGBW FX TABLE				
Type	Slot	DMX	Name	FX Adjustment
Intensity	11	11	Single	Reverse, Stop, Forward
	12	12	Single Bounce	Reverse, Stop, Forward
	13	13	Snake	Reverse, Stop, Forward
	14	14	Snake Bounce	Reverse, Stop, Forward
	15	15	Rows	Reverse, Stop, Forward
	16	16	Rows Bounce	Reverse, Stop, Forward
	17	17	Column	Reverse, Stop, Forward
	18	18	Column Bounce	Reverse, Stop, Forward
	19	19	Columns 2	Reverse, Stop, Forward
	20	20	Slash	Reverse, Stop, Forward
	21	21	Backslash	Reverse, Stop, Forward
	22	22	Slash Back	Reverse, Stop, Forward
	23	23	<>	Reverse, Stop, Forward
	24	24	><	Reverse, Stop, Forward
	25	25	>>	Reverse, Stop, Forward
	26	26	<<	Reverse, Stop, Forward
	27	27	Rotating Bar	Reverse, Stop, Forward
	28	28	Rotating Dot	Reverse, Stop, Forward
	29	29	Rotating 2 Dot	Reverse, Stop, Forward
	30	30	Ring 2 Cell	Reverse, Stop, Forward
	31	31	Ring 2 Cell Overlap	Reverse, Stop, Forward
	32	32	Ring 3 Cell Blend	Reverse, Stop, Forward
	33	33	Ring - Center Fade	Reverse, Stop, Forward
	34	34	X - Bar	Reverse, Stop, Forward
	35	35	Diagonals	Reverse, Stop, Forward
	36	36	Arrow Left	Reverse, Stop, Forward
	37	37	Arrow Right	Reverse, Stop, Forward
	38	38	2 Pixels	Reverse, Stop, Forward
	39	39	3 Pixels	Reverse, Stop, Forward
	40	40	4 Pixels	Reverse, Stop, Forward
	41	41	1,2,3,4 pixels	Reverse, Stop, Forward
	42	42	Ring Build	Reverse, Stop, Forward
	43	43	Ring Build Erase	Reverse, Stop, Forward
	44	44	Ring Build Erase 2	Reverse, Stop, Forward
	45	45	Chase 1	Reverse, Stop, Forward
	46	46	Chase 2	Reverse, Stop, Forward
	47	47	Chase 3	Reverse, Stop, Forward
	48	48	Chase 4	Reverse, Stop, Forward
	49	49	Chase 5	Reverse, Stop, Forward
	50	50	Chase 6	Reverse, Stop, Forward
	51	51	Chase 7	Reverse, Stop, Forward
	52	52	Chase 8	Reverse, Stop, Forward
	53	53	Chase 9	Reverse, Stop, Forward
	54	54	Chase 10	Reverse, Stop, Forward
	55-59	55-59	No Function	No Function
	60	60	Center Chase	Reverse, Stop, Forward
	61	61	Center Chase 2	Reverse, Stop, Forward
	62-100	62-100	No Function	No Function



RGBW FX TABLE				
Type	Slot	DMX	Name	FX Adjustment
Intensity	<b>REVISED WITH SOFTWARE UPDATE VERSION ≥1.1.1</b>			
	55	55	Center Chase	Reverse, Stop, Forward
	56	56	Center Chase 2	Reverse, Stop, Forward
	57	57	Alternate	Reverse, Stop, Forward
	58	58	Burst SparkLED	Reverse, Stop, Forward
	59	59	Burst RGBW	Reverse, Stop, Forward
	60	60	Strobe Alternate	Reverse, Stop, Forward
	62	62	Lens/SparkLED Alternate	Reverse, Stop, Forward
	66-100	66-100	No Function	No Function
	<b>REVISED WITH SOFTWARE UPDATE VERSION ≥1.3</b>			
	61	61	Lens/SparkLED Alternate	Reverse, Stop Forward
	62-100	62-100	No Function	No Function
Static Patterns	101	101	Top 2	Disabled
	102	102	Center 3	Disabled
	103	103	Bottom 2	Disabled
	104	104	Top and Bottom	Disabled
	105	105	X	Disabled
	106	106	Ring	Disabled
	107	107	Center Dot	Disabled
	108	108	Slash	Disabled
	109	109	Backslash	Disabled
	110	110	Arrow Left	Disabled
	111	111	Arrow Right	Disabled
	112	112	<	Disabled
	113	113	>	Disabled
114-130	114-130	No Function	No Function	

RGBW FX TABLE				
Type	Slot	DMX	Name	FX Adjustment
	131-255	131-255	No Function	No Function
Color	<b>REVISED WITH SOFTWARE UPDATE VERSION <math>\geq</math> 1.1.1</b>			
	131	131	RGBW Cells	Reverse, Stop, Forward
	132	132	RGBWCMY Cells	Reverse, Stop, Forward
	133	133	Color Wheel Cells	Reverse, Stop, Forward
	134	134	RGBW Rows	Reverse, Stop, Forward
	135	135	RGBWCMY Rows	Reverse, Stop, Forward
	136	136	Color Wheel Rows	Reverse, Stop, Forward
	137	137	RGBW Columns	Reverse, Stop, Forward
	138	138	RGBWCMY Columns	Reverse, Stop, Forward
	139	139	Color Wheel Columns	Reverse, Stop, Forward
	140	140	RGBW Single Row	Reverse, Stop, Forward
	141	141	RGBWCMY Single Row	Reverse, Stop, Forward
	142	142	Color Wheel Single Row	Reverse, Stop, Forward
	143	143	RGBW Single Columns	Reverse, Stop, Forward
	144	144	RGBWCMY Single Columns	Reverse, Stop, Forward
	145	145	Color Wheel Single Columns	Reverse, Stop, Forward
	146	146	RGB Rows	Reverse, Stop, Forward
	147	147	RGB Columns	Reverse, Stop, Forward
	148	148	Red White Cells	Reverse, Stop, Forward
	149	149	Green White Cells	Reverse, Stop, Forward
	150	150	Blue White Cells	Reverse, Stop, Forward
	151	151	Red Green Cells	Reverse, Stop, Forward
	152	152	Red Blue Cells	Reverse, Stop, Forward
	153	153	Blue Green Cells	Reverse, Stop, Forward
	154	154	Ring - Center Mix to Color Wheel	Reverse, Stop, Forward
	155	155	Random White Cell	Reverse, Stop, Forward
	156	156	Random White Row	Reverse, Stop, Forward
	157	157	Random White Column	Reverse, Stop, Forward
	158	158	White Flash	Reverse, Stop, Forward
	159	159	Red Flash	Reverse, Stop, Forward
	160	160	Green Flash	Reverse, Stop, Forward
	161	161	Blue Flash	Reverse, Stop, Forward
162	162	Color Wheel Flash	Reverse, Stop, Forward	
163	163	Alternate Color	Reverse, Stop, Forward	
	164-255	164-255	No Function	No Function

SparkLED FX TABLE				
Type	Slot	DMX	Name	FX Adjustment
<b>Waveform</b>	0	0	OFF	
	1	1	Sinewave (default) 	
	2	2	Step 	
	3	3	Sawtooth 	
	4	4	Ramp Up 	
	5	5	Ramp Down 	
	6-10	6-10	No Function	

SparkLED FX TABLE				
Type	Slot	DMX	Name	FX Adjustment
<b>Waveform</b>	<b>REVISED WITH SOFTWARE UPDATE VERSION <math>\geq</math>1.1.1</b>			
	0	0	OFF	
	1	1	<b>Sinewave Cross (default)</b> 	
	2	2	<b>Sinewave Full</b> 	
	3	3	<b>Sawtooth Cross</b> 	
	4	4	<b>Sawtooth Full</b> 	
	5	5	<b>Ramp Up</b> 	
	6	6	<b>Ramp Down</b> 	
	7	7	<b>Step</b> 	
	8-10	8-10	No Function	

<b>SparkLED FX TABLE</b>				
<b>Type</b>	<b>Slot</b>	<b>DMX</b>	<b>Name</b>	<b>FX Adjustment</b>
<b>SparkLED FX</b>	11	11	Starfield	Reverse, Stop, Forward
	12	12	1 Pixel	Reverse, Stop, Forward
	13	13	2 Pixels	Reverse, Stop, Forward
	14	14	3 Pixels	Reverse, Stop, Forward
	15	15	4 pixels	Reverse, Stop, Forward
	16	16	5 pixels	Reverse, Stop, Forward
	17	17	7 pixels	Reverse, Stop, Forward
	18	18	14 pixels	Reverse, Stop, Forward
	19	19	Single Row	Reverse, Stop, Forward
	20	20	3 Rows	Reverse, Stop, Forward
	21	21	Single Column	Reverse, Stop, Forward
	22	22	3 Column	Reverse, Stop, Forward
	23	23	Pixel Ring Chase	Reverse, Stop, Forward
	24	24	Pixel Row Chase	Reverse, Stop, Forward
	25	25	Pixel Ring Chase 2	Reverse, Stop, Forward
	26	26	Center Out	Reverse, Stop, Forward
	27	27	Fireworks	Reverse, Stop, Forward
	28	28	Ring	Reverse, Stop, Forward
	29	29	Row	Reverse, Stop, Forward
	30	30	Snake	Reverse, Stop, Forward
	31-90	31-90	No Function	No Function
<b>SparkLED Lens Combos</b>	91	91	No Function	No Function
	92	92		
	93	93		
	94	94		
	95	95		
	96	96		
	97	97		
	98	98		
	99	99		
	100	100		

SparkLED FX TABLE				
Type	Slot	DMX	Name	FX Adjustment
Full Lens Patterns (all SparkLED in the lens # turn on together)	101	101	Single	Reverse, Stop, Forward
	102	102	Single Bounce	Reverse, Stop, Forward
	103	103	Snake	Reverse, Stop, Forward
	104	104	Snake Bounce	Reverse, Stop, Forward
	105	105	Rows	Reverse, Stop, Forward
	106	106	Rows Bounce	Reverse, Stop, Forward
	107	107	Column	Reverse, Stop, Forward
	108	108	Column Bounce	Reverse, Stop, Forward
	109	109	Columns 2	Reverse, Stop, Forward
	110	110	Slash	Reverse, Stop, Forward
	111	111	Backslash	Reverse, Stop, Forward
	112	112	Slash Back	Reverse, Stop, Forward
	113	113	<>	Reverse, Stop, Forward
	114	114	><	Reverse, Stop, Forward
	115	115	>>	Reverse, Stop, Forward
	116	116	<<	Reverse, Stop, Forward
	117	117	Rotating Bar	Reverse, Stop, Forward
	118	118	Rotating Dot	Reverse, Stop, Forward
	119	119	Rotating 2 Dot	Reverse, Stop, Forward
	120	120	Ring 2 Cell	Reverse, Stop, Forward
	121	121	Ring 2 Cell Overlap	Reverse, Stop, Forward
	122	122	Ring 3 Cell Blend	Reverse, Stop, Forward
	123	123	Ring - Center Fade	Reverse, Stop, Forward
	124	124	X - Bar	Reverse, Stop, Forward
	125	125	Diagonals	Reverse, Stop, Forward
	126	126	Arrow Left	Reverse, Stop, Forward
	127	127	Arrow Right	Reverse, Stop, Forward
	128	128	2 Pixels	Reverse, Stop, Forward
	129	129	3 Pixels	Reverse, Stop, Forward
	130	130	4 Pixels	Reverse, Stop, Forward
	131	131	1,2,3,4 pixels	Reverse, Stop, Forward
	132	132	Ring Build	Reverse, Stop, Forward
	133	133	Ring Build Erase	Reverse, Stop, Forward
	134	134	Ring Build Erase 2	Reverse, Stop, Forward
	135	135	Chase 1	Reverse, Stop, Forward
	136	136	Chase 2	Reverse, Stop, Forward
	137	137	Chase 3	Reverse, Stop, Forward
	138	138	Chase 4	Reverse, Stop, Forward
	139	139	Chase 5	Reverse, Stop, Forward
	140	140	Chase 6	Reverse, Stop, Forward
	141	141	Chase 7	Reverse, Stop, Forward
	142	142	Chase 8	Reverse, Stop, Forward
	143	143	Chase 9	Reverse, Stop, Forward
	144	144	Chase 10	Reverse, Stop, Forward
	145	145	Center Chase	Reverse, Stop, Forward
	146	146	Center Chase 2	Reverse, Stop, Forward
147-200	147-200	No Function	No Function	

<b>SparkLED FX TABLE</b>				
<b>Type</b>	<b>Slot</b>	<b>DMX</b>	<b>Name</b>	<b>FX Adjustment</b>
<b>Full Lens Static Patterns</b> (all SparkLEDs in lens turn on together)	201	201	Top 2	Disabled
	202	202	Center 3	Disabled
	203	203	Bottom 2	Disabled
	204	204	Top and Bottom	Disabled
	205	205	X	Disabled
	206	206	Ring	Disabled
	207	207	Center Dot	Disabled
	208	208	Slash	Disabled
	209	209	Backslash	Disabled
	210	210	Arrow Left	Disabled
	211	211	Arrow Right	Disabled
	212	212	<	Disabled
	213	213	>	Disabled
	214-225	214-225	No Function	No Function
<b>SparkLED Pattern</b>	226	226	Row 1	Disabled
	227	227	Row 2	Disabled
	228	228	Row 3	Disabled
	229	229	Row 4	Disabled
	230	230	Row 5	Disabled
	231	231	Row 6	Disabled
	232	232	Row 7	Disabled
	233	233	Column 1	Disabled
	234	234	Column 2	Disabled
	235	235	Column 3	Disabled
	236	236	Column 4	Disabled
	237	237	Column 5	Disabled
	238	238	Column 6	Disabled
	239	239	Column 7	Disabled
	240	240	Ring 1	Disabled
	241	241	Ring 2	Disabled
	242	242	Ring 3	Disabled
243-255	243-255	No Function	No Function	

# DIMMER CURVES

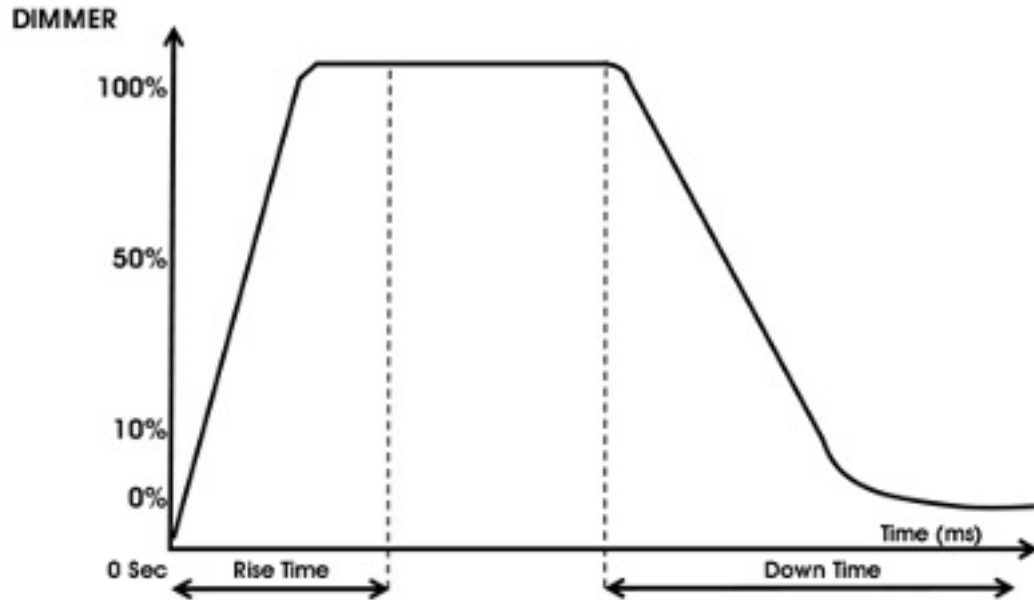

Dimming Curve Ramp Effect	0 sec Fade Time		1 sec Fade Time	
	Rise Time (ms)	Down Time (ms)	Rise Time (ms)	Down Time (ms)
Standard (default)	0	0	0	0
Stage	780	1100	1540	1660
TV	1180	1520	1860	1940
Architectural	1380	1730	2040	2120
Theatre	1580	1940	2230	2280
Stage 2	0	1100	0	1660

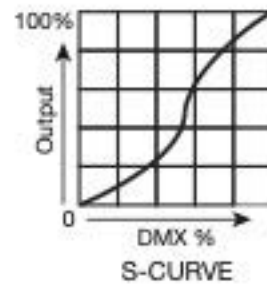
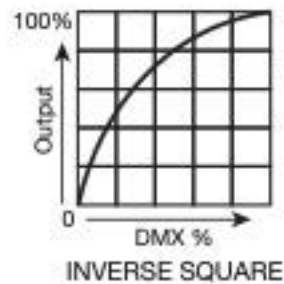
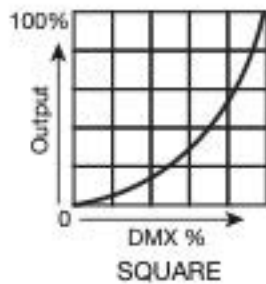
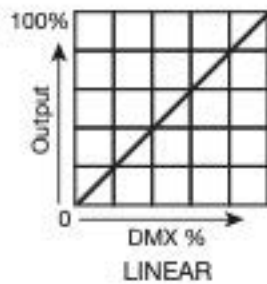



# ERROR CODES

When power is applied, the unit will automatically enter a “Reset/Test” mode. This mode brings all the internal motors to a home position. If there is an internal problem with one or more of the motors an error code will flash in the display in the form of “XXEr” where as XX will represent a function number. For example, when the display shows “0Er” it means there is some type of error with the Pan motor. If there are multiple errors during the start-up process they will all flash in the display. For example: if the fixtures has errors on **Channel 1, 2, and 5** all at the same time, you will see the error message “01Er”, “02Er”, and ”05Er” flash repeated 5 times.

If an error does occur during the initial start-up procedure the fixture will self-generate a second reset signal and try to realign all the motors and correct the errors. If the error persists after a second attempt a third attempt will be made. If after a third attempt all the errors have not been corrected the fixture will make the following determinations:

- **3 or More Errors** - The fixture cannot function properly with three or more errors therefore the fixture will place itself in a stand-by mode until subsequent repairs can be made.
- **Less Than 3 Errors** - The fixture has less than 3 errors; therefore, most other functions will work properly. The fixture will attempt to operate normally until the errors can be correct by a technician. The errors in question will remain flashing in the display as a reminder of internal errors.

Error Codes are subject to change without any prior written notice.	
ERROR CODES	DESCRIPTION
<b>PAN Er</b>	Movement is not located in the default position after the reset. This message will appear after a fixture reset if the magnetic-indexing circuit malfunctions (sensor failed, or magnet is missing) or there is a motor failure (defective motor or a defective motor IC drive on the main PCB). This error may also be displayed if the head/yoke was blocked during a reset function.
<b>TILT Er</b>	
<b>Zoom Er</b>	Movement is not located in the default position after the reset. This message will appear after a fixture reset if the magnetic-indexing circuit malfunctions (sensor failed, or magnet is missing) or there is a motor failure (defective motor or a defective motor IC drive on the main PCB).

# SOFTWARE UPDATES

Software updates for this fixture can be performed using the USB Port or the Elation Ethernet Updater. Contact Elation Service for assistance, or to obtain the updater device:

**ELATION SERVICE USA - Monday - Friday 8:00am to 4:30pm PST**  
323-582-3322 | Fax 323-832-9142 | [support@elationlighting.com](mailto:support@elationlighting.com)

**ELATION SERVICE EUROPE - Monday - Friday 08:30 to 17:00 CET**  
+31 45 546 85 63 | Fax +31 45 546 85 96 | [support@elationlighting.eu](mailto:support@elationlighting.eu)

## USB Update

To update the fixture software via the **UPDATE/SERVICE PORT**, refer to the steps shown below.



**ONLY QUALIFIED TECHNICIANS SHOULD PERFORM THIS FUNCTION!**  
**NOTE ALL MENU SETTINGS BEFORE UPDATING SOFTWARE!**  
**FIXTURE SOFTWARE CAN NOT BE DOWNGRADED!**  
**DOWNLOAD FIXTURE SOFTWARE TO PC ONLY! (NO MAC SUPPORT)**  
**PLEASE CONTACT ELATION SERVICE FOR FURTHER INFORMATION.**

1. Copy fixture software update file from a PC computer to a compatible USB flash drive.  
Make sure only the fixture software update file is stored on the USB flash drive.
2. Disconnect DMX, Art-Net, and E-FLY connections and power the fixture ON.
3. Insert USB flash drive into the **UPDATE/SERVICE PORT** on the rear connection panel.
4. Navigate to the **Personality** main menu **Service Setting / USB Update** sub menu.
5. Select the software file name on the menu display and press **ENTER**.
6. Select **YES** to begin update process and **Updating...%** will show on the menu display.
7. After file is uploaded, the fixture will check the software which will take some time.  
The fixture will perform a reset process when the software update process is complete.
8. Remove the USB flash drive and make necessary system menu setting adjustments.

# SOFTWARE UPDATES

The Elation Ethernet Updater is an EXE file, which only works on a PC System. Once you've received the Elation Ethernet Updater RAR file from Elation Service via email, download and extract the EXE file. With the file extracted, click **Elation Ethernet Updater setupV100.exe** to launch the installation wizard.



Follow the prompts once the Elation Ethernet Updater EXE has launched the Setup Wizard.

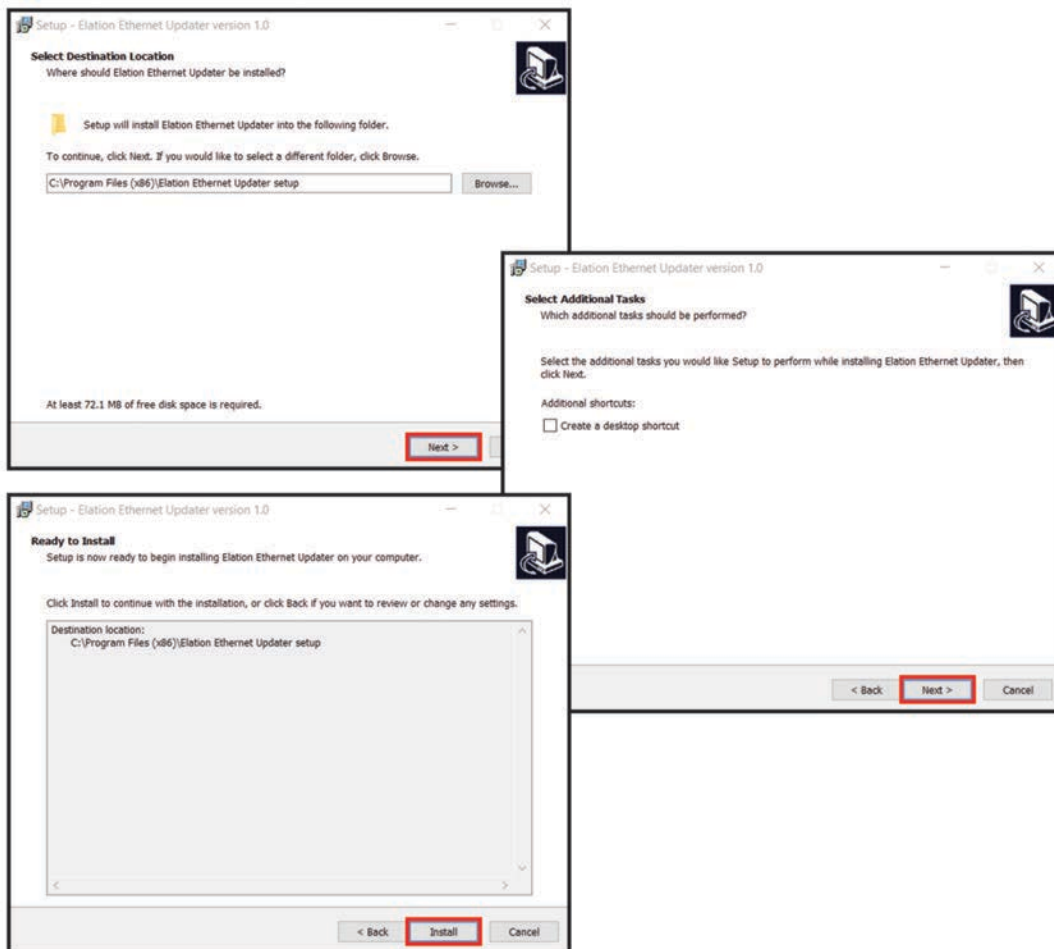

# SOFTWARE UPDATES

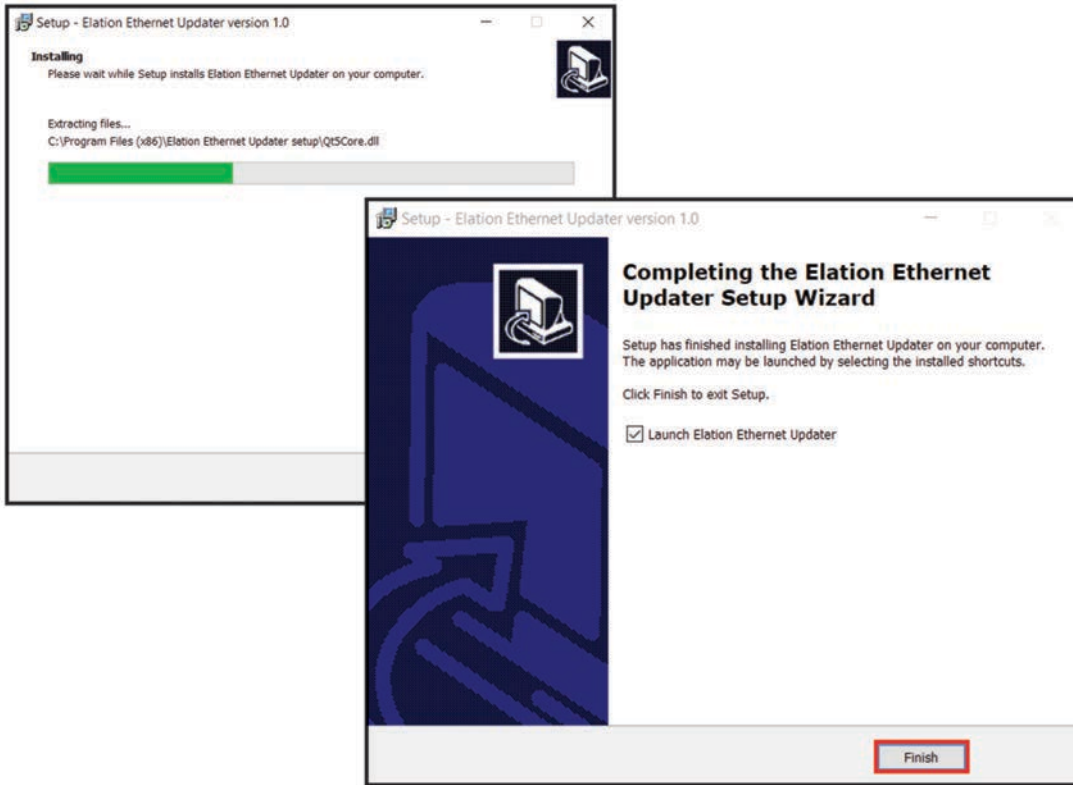

Once you have installed the Elation Ethernet Updater, it will launch automatically (unless you unchecked “Launch Elation Ethernet Updater”), or you can open it any time by clicking on the icon.

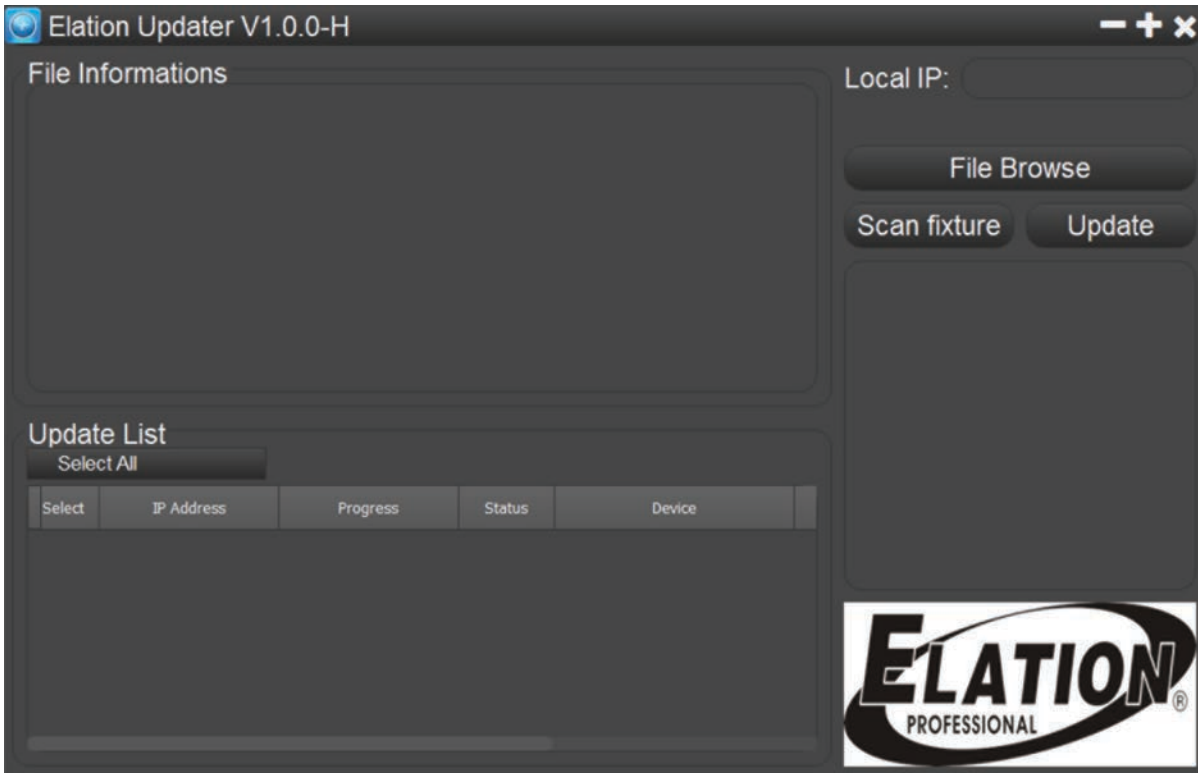

# SOFTWARE UPDATES

Once opened, your local IP will automatically be identified. Click “Scan fixture” and create a connection. The fixture identity will appear in the Update List on the left side of browser. A connection will fail to establish if the fixture IP and Local IP are not in the same network segment.

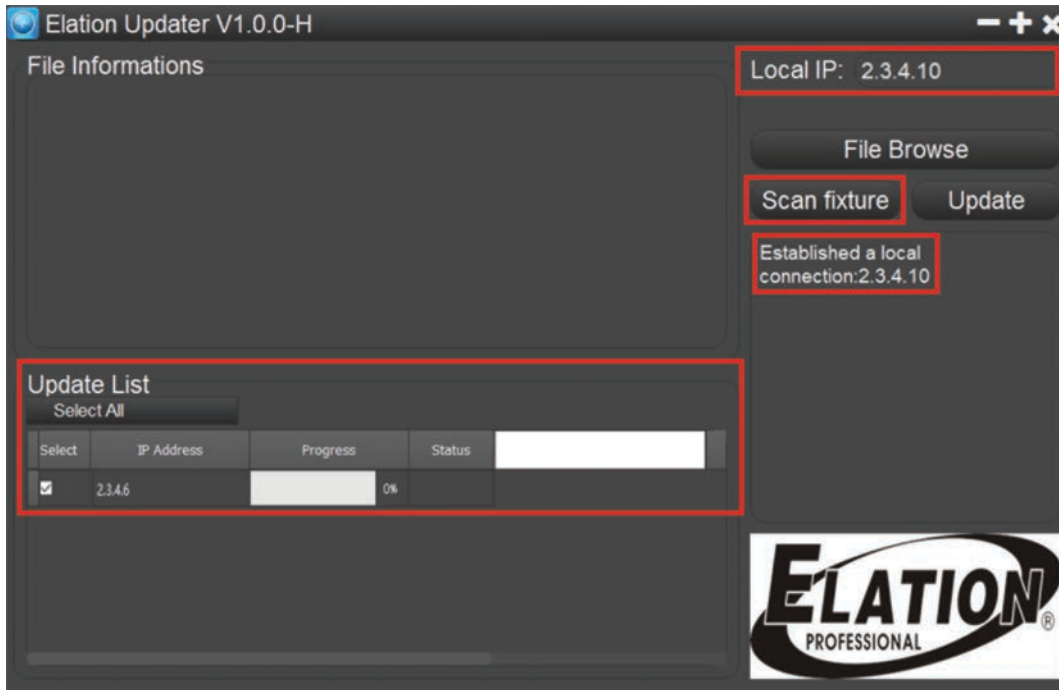

Click “File Browse” to select the files you want to download. The download Progress is displayed in the File information chart as a percentage bar graph.

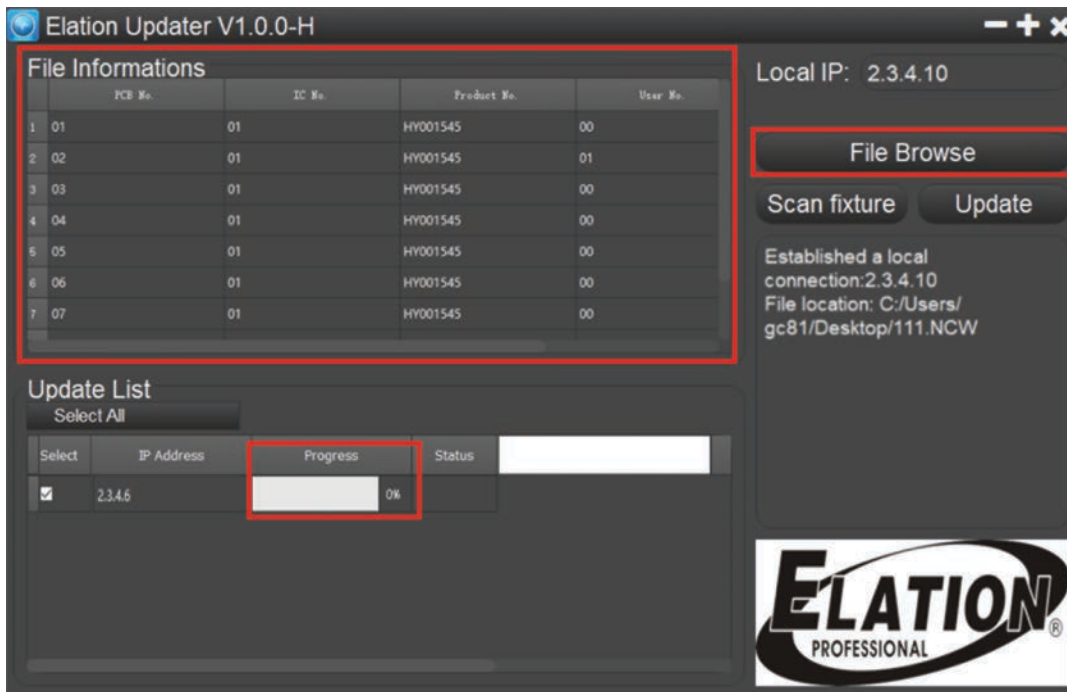

# SOFTWARE UPDATES

Click Update, then wait for the download Progress to reach 100% before closing Updater. The Elation Ethernet Updater can update up to 31 fixtures via connection to a PC.

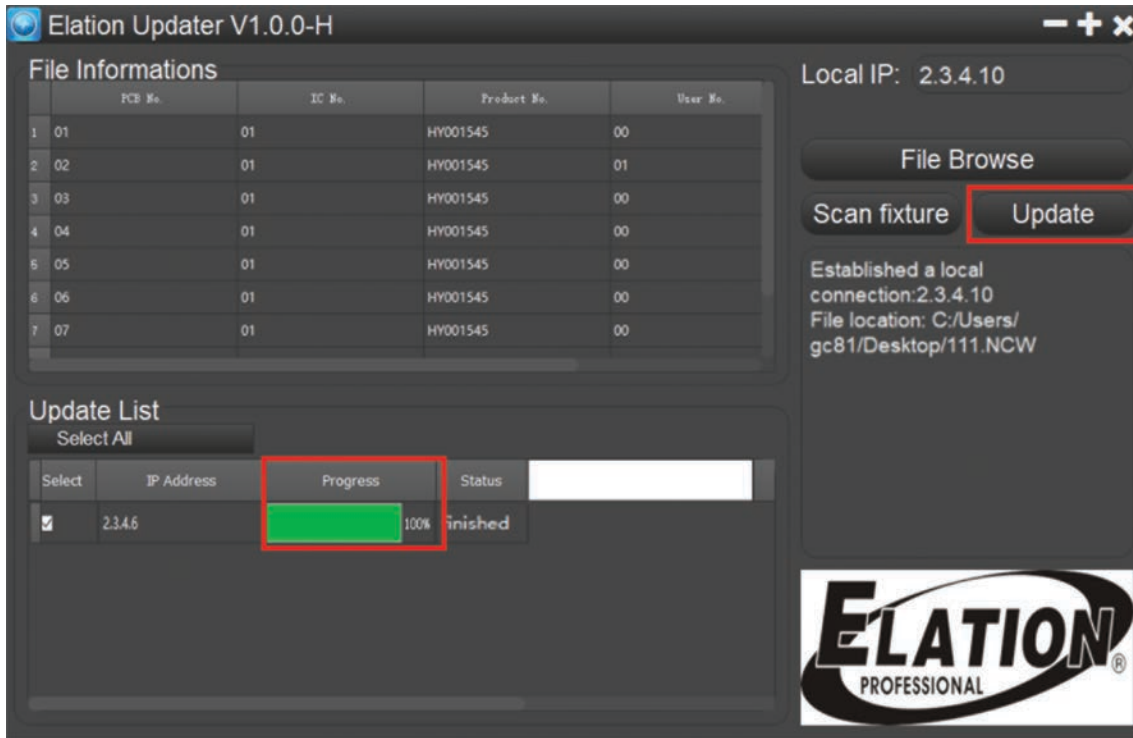

# **SPECIFICATIONS**

## **SOURCE**

(7) 60W Osram RGBW LEDs  
(28) 2W White SparkLED™  
50,000 Hour Average LED Life\*

\*Test lab conditions. May vary depending on several factors including but not limited to:  
Environmental Conditions, Power/Voltage, Usage Patterns (On-Off Cycling), Control, and Dimming.

## **PHOTOMETRIC DATA**

8,400 Total Lumen Output  
CRI 80  
Zoom Range 5° - 77°  
Beam Angle 5.4° - 57.3°  
Field Angle 7.4° - 73.3°

## **EFFECTS**

Motorized Zoom  
Linear Color Temperature Presets (2,700 - 8,000K)  
RGBW Color Mixing and Pixel Control  
White SparkLED Lens Effect  
Color Presets and Macros  
Electronic Strobe and Variable Dimming Curves  
16-bit Dimming  
Pan Angle: 540°/630°  
Tilt Angle: 270°/360°

## **CONTROL / CONNECTIONS**

3 DMX Channel Modes (25 / 52 / 80)  
360° Continuous Pan and Tilt Movement  
900 - 25,000 Hz DMX Adjustable Refresh Rate  
6 Button Touch Panel  
Full Color 180° Reversible LCD Menu Display  
DMX, RDM, Art-NET, and sACN Protocol Support  
5pin XLR DMX In/Out  
RJ45 Ethernet In/Out  
Locking Power Cable In/Out  
USB Connection (Firmware Updates)  
With Wired Digital Communication Network

## **SIZE / WEIGHT**

Length: 13.4 in (340.4mm)  
Width: 8.58 in (218.0mm)  
Height: 16.67 in (423.4mm)  
Weight: 27.0 lbs. (12.2kg)

## **ELECTRICAL / THERMAL**

AC 100-240V - 50/60Hz  
700W Max Power Consumption  
14°F to 113°F (-10°C to 45°C)  
BTU/hr (+/- 10%) 2216.5

## **APPROVALS / RATINGS**

CE | cETLus | IP20

Specifications and improvements in the design of this unit and this manual are subject to change without notice.

# DIMENSIONAL DRAWINGS

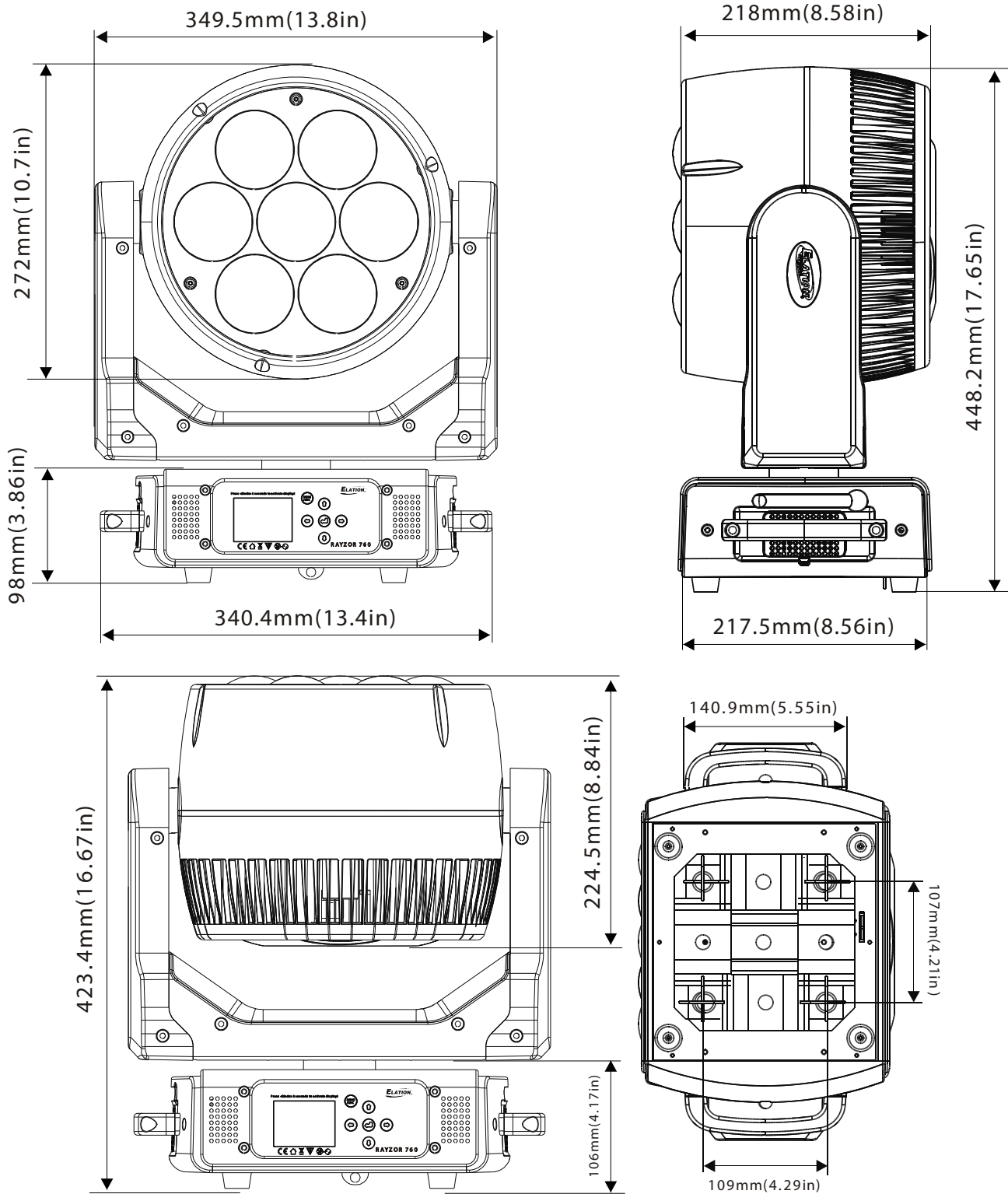

Specifications and improvements in the design of this unit and this manual are subject to change without notice.



## OPTIONAL ACCESSORIES

ORDER CODE	ITEM
DRCRAY760	Quad Road Case for RAYZOR 760
TRIGGER CLAMP	Heavy Duty Wrap Around Hook Style Clamp
AC5PDMX5PRO	5 ft. (1.5m) 5pin PRO DMX Cable
NEU096	5 ft. (1.5m) Power Cable
	Additional Cable Lengths Available

### FCC STATEMENT

This device complies with Part 15 of the FCC Rules. Operation is subject to the following two conditions: (1) this device may not cause harmful interference, and (2) this device must accept any interference received, including interference that may cause undesired operation.

### FCC RADIO FREQUENCY INTERFERENCE WARNINGS & INSTRUCTIONS

This product has been tested and found to comply with the limits as per Part 15 of the FCC Rules. These limits are designed to provide reasonable protection against harmful interference in a residential installation. This device uses and can radiate radio frequency energy and, if not installed and used in accordance with the included instructions, may cause harmful interference to radio communications. However, there is no guarantee that interference will not occur in a particular installation. If this device does cause harmful interference to radio or television reception, which can be determined by turning the device off and on, the user is encouraged to try to correct the interference by one or more of the following methods:

- Reorient or relocate the device.
- Increase the separation between the device and the receiver.
- Connect the device to an electrical outlet on a circuit different from which the radio receiver is connected.
- Consult the dealer or an experienced radio/TV technician for help.

Europe Energy Saving Notice

Energy Saving Matters (EuP 2009/125/EC)

Saving electric energy is a key to help protecting the environment. Please turn off all electrical products when they are not in use. To avoid power consumption in idle mode, disconnect all electrical equipment from power when not in use. Thank you.



