

# Oil Alert™ 2-Zone Alarm Panel



Leading Edge Control Products

Standard | Rated Type 1, Indoor Alarm Panel

MODEL: VA-03, ALARM PANEL ONLY (USE WITH ALDERON™ OIL ALERT™ SERIES)

TECHNICAL DATA SHEET

## DESCRIPTION OF OPERATION



The Oil Alert™ 2-Zone Alarm is an indoor rated alarm panel, powered by a standard 120VAC wall outlet. The green power LED will illuminate (solid) when powered. The alarm panel is used with Alderon™ Oil Alert™ control panels (standard and overload) for the safe operation of pumping, alarming, and monitoring of: elevator sump pits, transformer vaults, and leachate well applications. The Oil Alert™ control panel will activate a pump to remove water from pits in accordance with ASME A17.1, stopping the pump before oil or other harmful substances enter the water supply.

The alarm panel is equipped with audible and visual alarm indication for high oil and high water events. A preset level sensor is wired to the control panel from the monitoring area and the control panel auxiliary contacts are wired to the terminal block on the alarm panel. Installing a 9VDC battery (not included) provides battery backup during power outages. Use the alarm panel auxiliary contacts to connect to building automation systems (BAS) and phone dialers.

An alarm condition occurs when the sensor for high oil and/or high water activates the control panel's auxiliary contacts. During an alarm condition, the red alarm LED(s) will illuminate (solid), buzzer will annunciate (solid), and the auxiliary contacts will activate. Press the alarm silence pushbutton during an alarm condition to silence the buzzer, the alarm LED(s) will remain on until the sensor deactivates. The silence condition will reset when the sensor deactivates and the alarm panel will auto reset for the next alarm cycle.

NOTE: If zone-1 (high oil) is in an alarm condition and the buzzer is silenced, and then zone-2 (high water) goes into an alarm condition, the buzzer will reactivate until the alarm silence pushbutton is pressed to acknowledge that a new alarm condition has occurred.

## STANDARD FEATURES



(1) **Power LED** - A green LED illuminates (solid) on the front of the alarm panel to indicate the power is on.

(2) **Alarm LEDs** - During an alarm condition in zone-1 and/or zone-2, the red alarm LED(s) will illuminate (solid) on the front of the alarm panel.

(3) **Alarm Buzzer** - The alarm buzzer will annunciate (solid) in addition to the visual indication provided by the red alarm LED(s) during an alarm condition.

(4) **Alarm Test Pushbutton** - Press the pushbutton to test the alarm to ensure proper operation. The buzzer should annunciate, alarm LEDs should illuminate, and auxiliary contacts should activate.

(5) **Alarm Silence Pushbutton** - Press the pushbutton to silence the buzzer during an alarm condition. The alarm LED(s) remain illuminated until the alarm condition has been cleared and the alarm panel will auto reset for the next alarm cycle.

(6) **Signaling Device (INPUTS)** - Connect the Oil Alert™ control panel auxiliary contacts to the terminal block on the alarm panel.

(7) **Auxiliary Contacts (OUTPUTS)** - Interface with an external device including BAS systems and phone dialers. The normally open dry contacts can switch 24VDC, 500mA maximum (each).

(8) **Battery Backup** - Install a 9VDC battery (not included) for battery backup during power outages. The power LED will not illuminate during battery backup mode to conserve battery power.

(9) **Panel Access** - Pull the cover off to access the panel, includes an open wiring compartment to safely route wires while connecting the signaling device and auxiliary dry contacts.

# SPECIFICATIONS

## Oil Alert™ 2-Zone Standard Alarm, Panel Only



**Primary Power**  
120VAC, 50/60 Hz

**Circuit Board Primary Power**  
11.1VDC, 500mA maximum

**Circuit Board Secondary Power**  
9VDC, standard 9VDC battery  
(battery backup; not included)

**Watts**  
1.4 Watts

**Field Connection Sensor**  
9-10VDC, 200mA minimum  
(control panel signaling device)

**Auxiliary Contacts**  
24VDC, 500mA maximum (each)  
Normally Open  
Terminals COM and 1A = High Oil  
Terminals COM and 2A = High Water

**Auxiliary Alarm Power**  
8-10.2VDC, 150mA maximum

**LEDs**  
Green (power) and Red (alarm)

**Buzzer**  
85 dB @ 10-feet

**Wall-Mounted Power Supply**  
120VAC, 50/60 Hz (input)  
11.1VDC, 500mA maximum (output)  
(6-foot cord)

**Enclosure**  
Thermoplastic  
5 x 4 x 1.3 (inches)  
Type 1, Indoor  
Removable cover

**Certifications**  
CSA (US and Canada)

**Three-Year Limited Warranty**

## MECHANICAL DRAWING

Oil Alert™ 2-Zone Alarm Panel (front view)

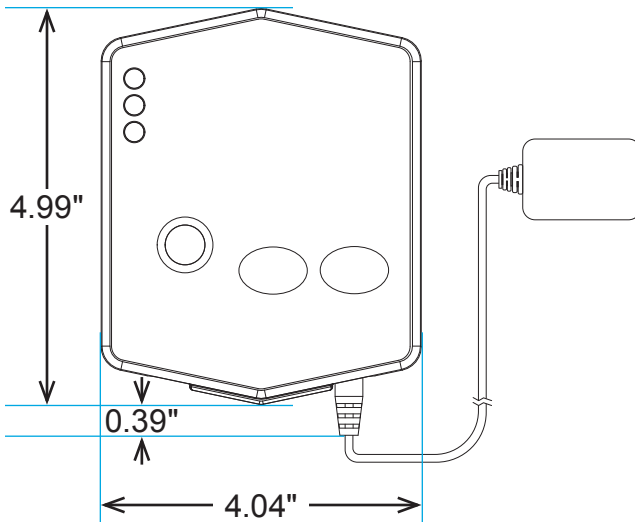

Oil Alert™ 2-Zone Alarm Panel (side view)

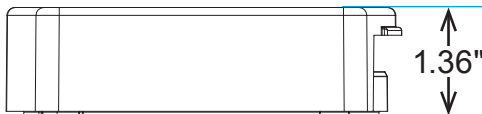

## WIRING EXAMPLES

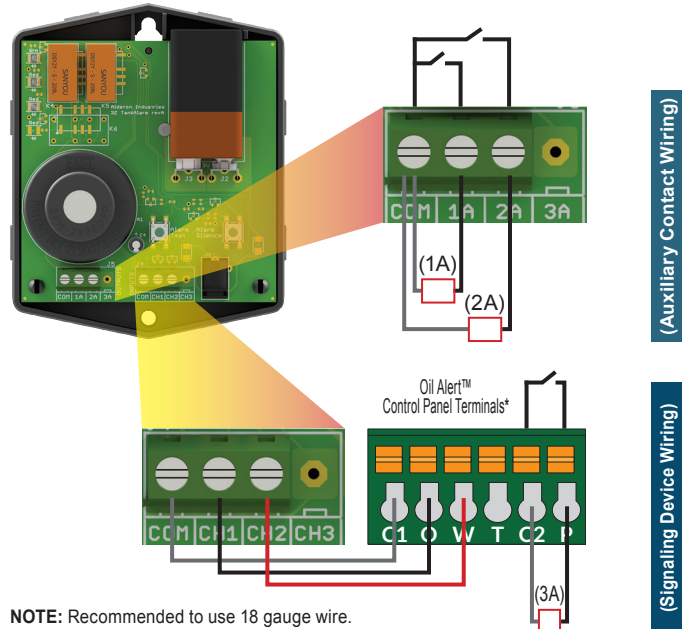

**NOTE:** Recommended to use 18 gauge wire.

**WARNING:** The alarm panel contacts are low voltage wires, follow National Electrical Code (NEC) requirements pertaining to separation of voltages if run in the same conduit/cable grip or junction box with high voltage wires.

**Oil Alert™ Alarm Panel Auxiliary Contact Terminals (OUTPUTS):**

COM and 1A = Zone-1, High Oil (connects to external monitoring device; i.e., 1A)  
COM and 2A = Zone-2, High Water (connects to external monitoring device; i.e., 2A)

**Oil Alert™ Alarm Panel Signaling Device Terminals (INPUTS):**

COM = Common (connects to Oil Alert™ control panel TB-C1)  
CH1 = Oil Alarm (connects to Oil Alert™ control panel TB-O)  
CH2 = Water Alarm (connects to Oil Alert™ control panel TB-W)

**(\*) Oil Alert™ Control Panel Terminals. Pump Run Auxiliary Contacts:**

C2 and P = Pump Run (connects to external monitoring device; i.e., 3A)

## ORDERING INFORMATION

For a complete list of standard products with pricing, refer to the current year price sheet or visit [alderonind.com](http://alderonind.com) for more information.

PART NUMBER	DESCRIPTION (Alarm Panel includes: Auto Reset, Battery Backup, and Auxiliary Contacts)
2010532	Oil Alert™ 2-Zone - Standard Alarm, High Oil/High Water (Alarm Panel Only)