

Oil Alert™ Control Panel

Three Phase Duplex, Type 4X (Indoor/Outdoor)

Model: OAHO3D | 208/230/460VAC or 230/460/575VAC; Specified Amp Ranges

OPAQUE DOOR, ALARM BEACON, and LOCKABLE LATCHES



Leading Edge Control Products

MARKETING DATA FLIER

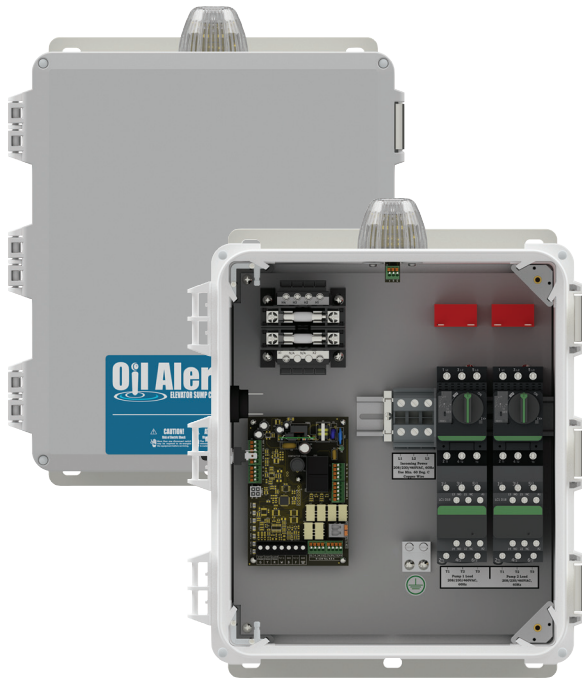

STANDARD FEATURES

- **Type 4X Enclosure, Indoor or Outdoor Use, Pad-Lockable**
 - Standard Enclosure Size 14" x 12" x 6" (inches)
 - Opaque Door, Alarm Beacon with Red Flashing LEDs
 - Inner Door, View OLED Screen with Alarm and Status Indicator LEDs
 - Alarm Buzzer and Alarm Test/Silence Switch
- **Pump Motor Protective Switches (MPS) and IEC Contactors**
 - Combination Circuit Breaker, IEC Contactor Pump Starter, and Overload Relay with an Adjustable Pump Amp Range which Protects the Pumps from Overcurrent Damage or use MPSs for Pump Disconnect
- **Beacon with Vibrant Multi-Color LEDs (select indicators listed)**
 - Green (normal), Red (alarms), Blue (pump run), and Red/Yellow (error)
- **Automatic Resettable Alarm and Control Fuses**
- **Built-in Printed Circuit Board Surge Protection (conformal coated)**
- **Easily Change Configurations**
 - Sump Applications, Preset Level Sensor with a Fixed or Adjustable Pumping Range
 - Lift Station Applications, (3) or (4) Float Switches and (1) Oil Probe
 - Enable Pump Exerciser
 - Enable Fire Input Mode, System Pumps Oil or Water when Activated
- **Statistic Tracking (each pump)**
 - Pump Elapsed Time, Min/Max/Avg Pump Run Times, Pump Cycle Counter, Pump Amperage Stats, Pump Fail Stats, Total Gallons Pumped, High Level Stats, Oil Alarm Stats, and More
- **Included Auxiliary "Dry" Contacts**
 - High Oil, High Water, Trouble Alarm (P1/P2), and Pump Run (P1/P2)
- **Hand-Off-Auto (HOA) Pump Selector Switch (each pump)**
 - Off Reminder, Yellow Flashing LEDs and Displays "Pumps Disabled"
 - Configurable Pump Disable
- **Scroll Wheel and Digital Display (password protected settings)**
 - Navigate Menu, Access Statistics Tracking, Configure Settings, and Displays System Information on OLED Screen
- **Exterior Test/Silence Switch**
 - Quick View of Pump and Alarm Stats
 - Check Alarm LEDs and Buzzer or Silence Buzzer during Alarm

Panel Options (customize application)

- Seal and Thermal Pump Sensors
- Anti-Condensation Heater
- Main Disconnect
- Lightning Arrestor
- Sensors for Sump or Lift Station Applications
- Enclosure Size Upgrades

ORDERING INFORMATION

For a complete list of standard products with pricing, refer to the current price sheet or scan the QR code for more information on this product.



OIL ALERT™ - THREE PHASE | DUPLEX

Base Model	Control Panel Description			
OAHO3D	Oil Alert™ Hard Wired, Opaque Door, Beacon, Three Phase Duplex, 208/230/460VAC (460) or 230/460/575VAC (575)			
Panel Code	Pump Full Load Amps (FLA)	Control Switch Options	Panel Code	Description (narrow angle models only)
CO1-1.6	1.0 - 1.6 Amps	OR	+S	Sump Applications (see below)
CO1.6-2.5	1.6 - 2.5 Amps		25	25' Cable Length
CO2.5-4	2.5 - 4.0 Amps		50	50' Cable Length
CO4-6	4.0 - 6.0 Amps		100	100' Cable Length
CO6-10	6.0 - 10.0 Amps		OS	Fixed Pumping Range (6")
CO9-14	9.0 - 14.0 Amps		VOS	Adjustable Pumping Range (1"-44")
CO13-18	13.0 - 18.0 Amps		+L	Lift Station Applications (see below)
CO17-23	17.0 - 23.0 Amps		3	(3) Float Switches & (1) Oil Probe
CO20-25	20.0 - 25.0 Amps		4	(4) Float Switches & (1) Oil Probe
			Sensor Cable Length (float switch and oil probe)	F20P20
			F30P30	30' Cable Length
			F50P50	50' Cable Length

Example: OAHO3D575CO1.6-2.5+L4F50P50X = Oil Alert™, Opaque Door, Beacon, Three Phase Duplex, 230/460/575 Volts, 1.6-2.5 Amps, (4) 50' Control Switches, Cast Iron Weights, 50' Oil Probe

Oil Alert™ Control Panel | PRODUCT DIMENSIONS and APPLICATION EXAMPLES

Visit alderonind.com to expand your system with other Alderon™ products for standard or custom applications

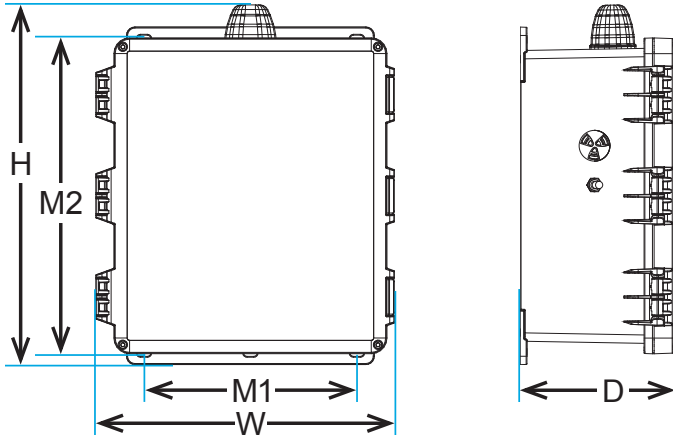

PANEL CODE (enclosure size)	OVERALL Width (W)	OVERALL Height (H)	OVERALL Depth (D)	MOUNTING Width (M1)	MOUNTING Height (M2)
Base Model (E3) 14 x 12 x 6	14.01	17.85	7.27	10.24	14.83
E4 16 x 14 x 8	16.09	19.85	9.27	12.24	16.91
E5 18 x 16 x 10	18.16	21.85	11.27	14.25	18.99
Enclosure measurements (inches)					

APPLICATION EXAMPLES

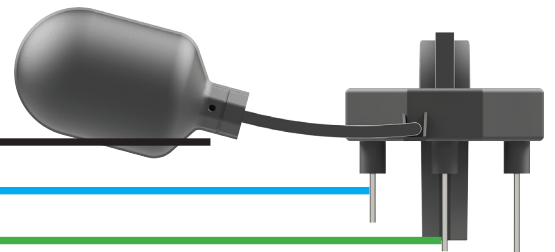

"OIL DETECTION" High Level Float

If oil, hydrocarbon, or other harmful substances are floating on top of the water level touching the high water probe while simultaneously activating the high level float switch, then a high oil alarm (oil detected) condition occurs and the pump continues to run as long as water and not oil is touching the pump start and pump stop probes.

"HIGH WATER" Sensor Level Probe

If the water level rises touching the high water probe, a high water alarm condition occurs and the pump continues to run, (also a redundant pump start/pump run function; duplex will activate the lag pump). The alarm condition automatically resets (factory default) when water is no longer touching the high water probe.

"PUMP START" Sensor Level Probe

As the water level rises touching the pump start probe, the pump will start and continue to run until the water level recedes below the pump stop probe to complete the pump cycle. The control panel displays a pump run event with LEDs while the pump is running.

"PUMP STOP" Sensor Level Probe

When the water level is no longer touching this probe, the pump will stop running so the oil layer will not be pumped out of the sump. Oil will float on top of water, so if oil is present and touching this probe, the pump will also stop running.

High Oil Alarm Condition (oil detection) | Sump Level Examples:

To determine the oil layer thickness in the sump/monitoring area during a high oil alarm condition, review the sensor LED status indicators or OLED display screen with illuminated LEDs for an approximate oil level in the sump. See below for diagrams and general system descriptions.

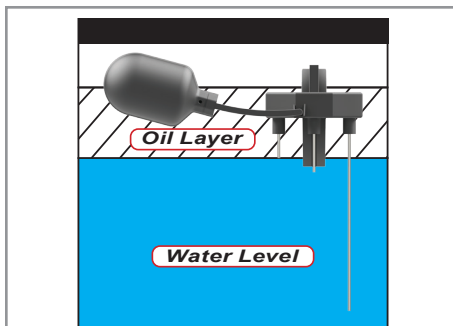

Example 1: If the panel P1, P2, and F1 LED status indicators are illuminated (solid), then the oil layer will be submerging the high water probe.

Example 2: If the panel OLED display screen shows "Sensor Status Inputs: 11010", then the oil layer will be submerging the high water probe.

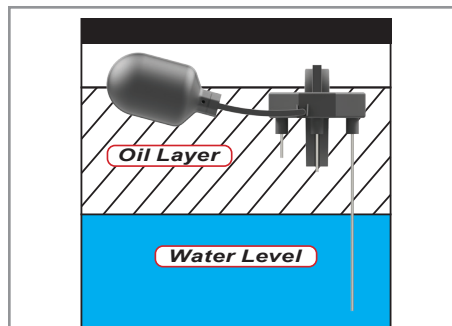

Example 1: If the panel P1 and F1 LED status indicators are illuminated (solid), then the oil layer will be submerging the high water and pump start probes.

Example 2: If the panel OLED display screen shows "Sensor Status Inputs: 10010", then the oil layer will be submerging the high water and pump start probes.

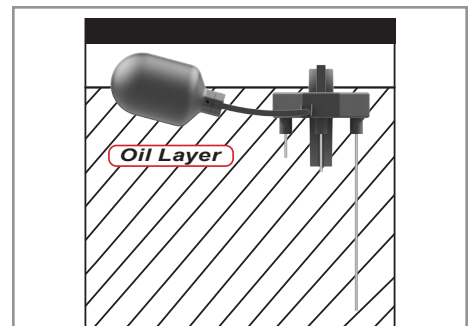

Example 1: If only the panel F1 LED status indicator is illuminated (solid), then the oil layer will be submerging the high water, pump start, and pump stop probes.

Example 2: If the panel OLED display screen shows "Sensor Status Inputs: 00010", then the oil layer will be submerging the high water, pump start, and pump stop probes.