

Oil Alert™ Control Panel

Standard, Single Phase Simplex | Type 4X (Indoor/Outdoor)
 Model: OA1S; 120VAC and 240VAC, 1-14A or 14-18A

INCLUDES: 25' PRESET LEVEL SENSOR and 3-ZONE REMOTE ALARM PANEL



Leading Edge Control Products

TECHNICAL DATA SHEET

DESCRIPTION OF OPERATION



The Oil Alert™ single phase simplex control panel is used for the safe operation of pumping, alarming, and monitoring of: elevator sump pits, transformer vaults, and leachate well applications. The control panel will activate a pump to remove water from pits in accordance with ASME A17.1, stopping the pump before oil or other harmful substances enter the water supply. Available in 120VAC and 240VAC, 1.0-14.0 Amps or 14.0-18.0 Amps, and a Type 4X (indoor/outdoor) enclosure. The control panel comes with a pre-installed female pump power receptacle, incoming system power cable, and preset level sensor.

The control panel is operated by the factory wired preset level sensor module for pump stop, pump start, high water alarm, and oil detection alarm (high level float switch). As the water level rises touching the pump start probe (middle), the pump will start and continue to run until the water level recedes below the pump stop probe (longest) to complete the pump cycle. The control panel pump run LED will illuminate when the pump is running and pump run auxiliary contacts will activate.

The pump stop probe senses air or oil and when the water level is no longer touching this probe, the pump stops running so the oil layer will not be pumped out of the sump. Oil will float on top of water, so if oil is present and touching this probe, the pump will also stop running. If the water level rises to activate the high water probe (shortest) and/or simultaneously activating the high level float switch, then a high water and/or high oil (oil detected) alarm condition will occur.

During an alarm condition the control panel LED(s) will illuminate while the auxiliary contacts activate the Oil Alert™ remote alarm. The auxiliary contacts of the alarm panel can be connected to a building automation system (BAS) or SCADA system and phone dialers for remote notification of alarm conditions.

STANDARD FEATURES



- (1) Type 4X Enclosure (indoor/outdoor rated)
- (2) Clear Cover to view Interior Components (not shown)
- (3) Mounting Brackets
- (4) Oil Alert™ Circuit Board, Status Indicators
- (5) Incoming System Power (control/alarm, pre-wired male plug)
- (6) Test/Configure Pushbutton
- (7) Pump Hand-Off-Auto Selector Switch
- (8) Remote Alarm Panel Auxiliary Contacts
- (9) Pump Run Auxiliary Contacts
- (10) Preset Level Sensor/Function Input Terminals (sensor only, pre-wired at factory; not shown)
- (11) Sensitivity Adjustment Dial (water sensors)
- (12) IEC Motor Contactor
- (13) Pump Power Receptacle (pre-wired female plug)
- (14) Pump Connection Terminals (pre-wired to female receptacle plug; not shown)
- (15) Ground Bar (5-position)
- (16) Pre-Installed Cable Grips (4)
- (17) Preset Level Sensor
 - 17a) Pump Stop, Sensor Level Probe
 - 17b) Pump Start, Sensor Level Probe
 - 17c) High Water, Sensor Level Probe
 - 17d) Oil Detection, High Liquid Level Switch

SPECIFICATIONS

Oil Alert™ OA1S Series Control Panel, Standard, Remote Alarm

Primary Power

120VAC, 1-14A or 1-18A, 60 Hz (120VAC pump)
240VAC, 1-14A or 1-18A, 60 Hz (240VAC pump)

Phase/Pump Type

Single Phase, Simplex

Pump Power Receptacle Cable

120VAC or 240VAC, 15A or 20A, 60 Hz
Female Plug (voltage/amps depends on model)

Incoming System Power Cable

120VAC or 240VAC, 15A or 20A, 60Hz
Male Plug (voltage/amps depends on model)
6-foot cable

IEC Motor Contactor

120VAC or 240VAC, 18A, 50/60 Hz
3-Pole, Normally Open

Auxiliary Dry Alarm Contacts

120VAC/24VDC, 250mA maximum (each)
Normally Open

Fuses

Positive Temperature Coefficient (PTC)
Resettable

LEDs

Green (power and pump run)
Red (alarm, activated sensor, or system setting)

Sensor Input Ratings

Float/Function Inputs, 3.3VDC
Water Probe Inputs, 12V

Preset Level Sensor

25-foot cable
SJEOOW (UL) / SJTOOW (CSA)
18 AWG, 5-conductor, flexible, and water/oil resistant

High Level Switch (preset level sensor)

1-foot cable
Narrow Angle, Normally Closed
SJOOW (UL/CSA)
18AWG, 2-conductor, flexible and water/oil resistant

Enclosure

Thermoplastic
8 x 6 x 4 (inches)
Type 4X, Indoor/Outdoor
Enclosure Screws

Certifications

UL 508 (US and Canada)

Three-Year Limited Warranty

Note: Refer to individual data sheets of the preset level sensor and alarm panel for full specifications for each product.

MECHANICAL DRAWING

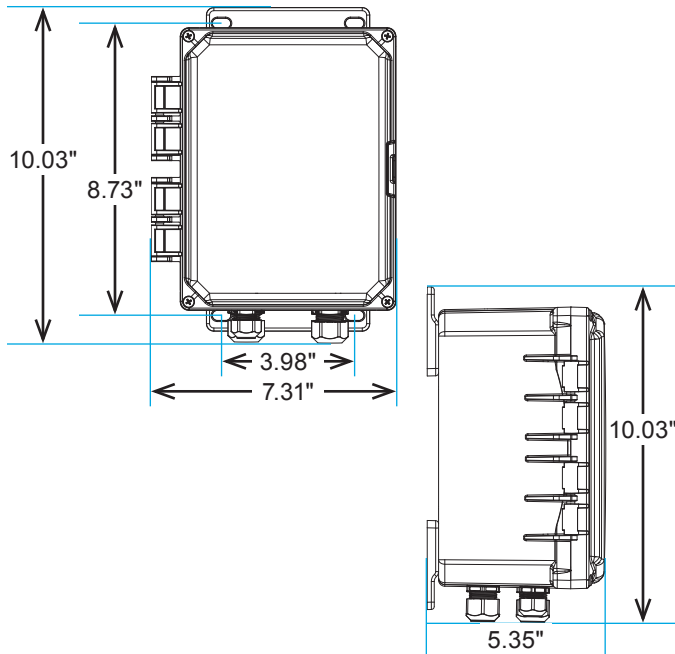

APPLICATION EXAMPLE

The preset level sensor (standard model) is the typical sensor option for Oil Alert™ control panel systems. This application example shows the basic functions of the sensor module that is installed in the monitoring area.

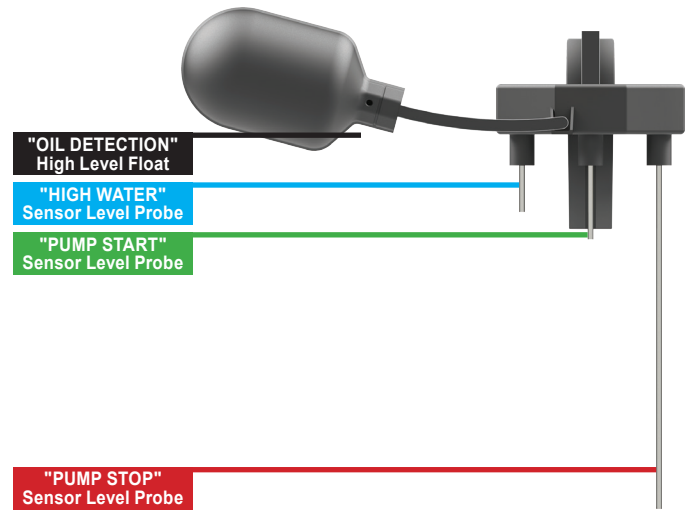

ORDERING INFORMATION

OA1S120C14+R+250S

1
2
3
4
5

Customized System Part Number:

MODEL # BOX 1	MODEL # BOX 2	MODEL # BOX 3	MODEL # BOX 4	MODEL # BOX 5
OA1S120				

NUMBER	CATEGORY	TYPE / EXAMPLE
1	Base Model and Voltage	OA1S120 = Oil Alert™ - Single Phase Simplex, 120VAC OA1S230 = Oil Alert™ - Single Phase Simplex, 230VAC
2	Pump Full Load Amps (FLA)	C14 = 1.0 - 14.0 Amps C18 = 14.0 - 18.0 Amps
3	Remote Alarm	+R = Oil Alert™ 3-Zone Standard Remote Alarm Panel
4	Preset Level Sensor Cable Length (feet; standard)	+25 = 25' Cable Length +50 = 50' Cable Length +100 = 100' Cable Length
5	Pumping Range (inches)	OS = Fixed Pumping Range, 6.0" (preset level sensor, standard) VOS = Adjustable Pumping Range, 1.0" - 44.0" (preset level sensor, adjustable probe)