

# TTD™ Series

## Configurable Fault Annunciator

The TTD product is a solid-state fault annunciator and shut-down control system designed to protect engines, pumps, compressors and associated equipment. The TTD model accepts 48 sensor inputs from normally open and/or normally closed sensors. Each of the 48 inputs can be configured for shutdown or alarm only. Any input can be locked out by one of the two start-run timers or configured as Class C, ESD or ignore. The annunciator provides for both closing of a fuel valve and grounding of an ignition after a time delay.

Incorporated in the TTD non-volatile memory:

- Run Hours/Elapsed Time Meter (hours roll over at 99,999)
- Last 10 shutdowns with associated run hours
- Last four alarms with associated run hours
- Selectable Modbus RTU slave RS232/RS485 serial communications
- Selectable baud rates

Optional Features:

- Pre/Post lube timed functionality
- Tachometer with overspeed and underspeed setpoints and running hours
- Lubricator no-flow detection for up to four proximity switches

With the TTD series, the display head is common to all configurations allowing fewer spare parts required to be maintained in the field. Its user-selectable templates provide ease of retrofit by selecting configuration of existing annunciators via display keypad or download from a computer with Windows-based MConfig™ installed.

### Power Supply

The power input and control output terminals are mounted on the plug-in power supply (PSU-2). Power supplies also include an RS485/RS232 serial communication port (MODBUS RTU slave) to interface with microcontrollers, PCs, PLCs and/or communication and control systems. The serial communication provides read and write register capability and selectable baud rate up to 38,400.

All power supply models are reverse polarity protected and can be powered by 10-32vdc or 90-400vdc negative ground CD ignition. The TTD annunciator is fully operable with the internal battery. The external DC power enables communications support (MODBUS slave) and turns on the display backlight.



### Display Head

The display head shows operational and configuration data. Configuration parameters are entered via keypad or downloaded from MConfig software.

The display head will accept digital inputs directly on the back of the unit. Power is provided to the display head via a direct Phoenix connector. The display head contains the microprocessor, LCD, membrane keys for configuring the sensors inputs and the sensor input terminal blocks.

The TTD LCD annunciates any fault from the sensor inputs, displays engine speed and run hours/elapsed time meter. Other features for the TTD are: built-in test mode function to check the sensor circuits without causing a fault shutdown; pre-lubrication and post-lubrication timers; and onboard backup battery to retain the fault display after shutdown on ignition powered units.

# Specifications

## Power Requirements:

**PSU-2:** 10-32 VDC, 10 W (max); 90-400 VDC CD Ignition, 750 uA @ 100 VDC (max)

**On-Board Backup Power:** Lithium battery, 6 VDC, 1300 mAh.

**Digital Inputs:** 48 (aka channels)

**Sensor Types:** Discrete input, N.O./N.C., non-incandive

**Magnetic Pickup Input:**

**One Magnetic Pickup Sensor Input:** 3.6 - 120 VAC, 2-10 kHz.

## Outputs:

**IGN:** 0.4 A @ 400 VDC\* for 5 seconds

0.15 A @ 400 VDC(\*) cont. duty

**RLY:** 0.5 A @ 48 VDC cont. duty

**FV-:** 0.5 A @ 400 VDC(\*) cont. duty

**ALR:** 0.5 A @ 48 VDC cont. duty

**AUX:** 0.5 A @ 48 VDC cont. duty

## Operator Interface:

**Display Type:** LCD, Static, 80 segment, custom text with LED backlight

**Display Viewable Area:** ~ 2.79 x 1 in. (71.04 mm x 25.4 mm)

**Display Contrast:** Automatic

**Display Backlight:** Yellow (Normal Operation); Red (Shutdown)

(Backlight will only be available when unit is powered by DC)

**Voltage Level Monitor:** Monitor and display voltage level of DC supply, CD ignition and internal battery

**Keypad:** 6 switches: Ridge Embossed, Metal Dome, Tactile 14 Oz. Trip Force

**Enclosure Cutout:** 5.50 x 5.50 in. (133 mm)

## Operating, Storage and Viewable Temperature:

-40° F - 185° F (-40° C to 85° C)

**VTachometer Accuracy:** ±0.5% of the display reading or ±1 RPM, whichever is greater

**Resettable Hourmeter Range:** 0 to 99999 hrs.

**Non-Resettable Hourmeter Range:** 0 to 99999 hrs.

**Hourmeter Accuracy:** ±1 hour per year

## Communication Ports: 1

A single bi-color (green/red) LED is provided to give visual indication of active transmit and receive traffic. Only one connection will be active at any time.

**Interface:** Factory configured for RS485; field-selectable for 3-wire RS232 or RS485

**Baud/Stop Bit Selections:** 9600, 19.2K, 38.4K<sup>†</sup>;N,8,1;N,8,2

**Protocol:** MODBUS RTU

**Connection:** There are two screw terminal connectors for RS485.

There are two screw terminal connectors for RS232. There is one screw terminal common for both ports labeled as GND.

## Third-Party Approvals:

TTD-H, PSU-2: CSA Class I, Division 2, Groups B, C and D

TTD-H: IEC 60529 - IP66 (NEMA 4 & 4 X equivalent)

**Intuitive Display Icons:** Display status and assist in setup and operation. The appropriate icon will turn on to indicate unit status or navigation through the setup features.

**RUN** – Run mode

**RPM** – Screen Value

**HOURS** – Screen Value

**TYPE** – Channel Type Configuration

**LOW BATT** – Low Battery Warning (displayed when condition exists)

**HISTORY** – Shutdown History

**TEST** – Test Mode

**LUBE** – Pre-lubrication Timer

**POSTLUBE** – Post-lubrication Timer

**SHUTDOWN** – Stop Mode

**ALARM** – Alarm(s) Warning (displayed when condition exists)

**SETPOINT** – Edit Set-point Value

**SETUP** – Setup Menu(s)

\* CSA approved for 250 VDC maximum

<sup>†</sup> 38.4 K baud will not be available when IGN input is selected as the source for RPM calculations. When MPU is selected, this feature is available for selection.

# Dimensions

## Display Head

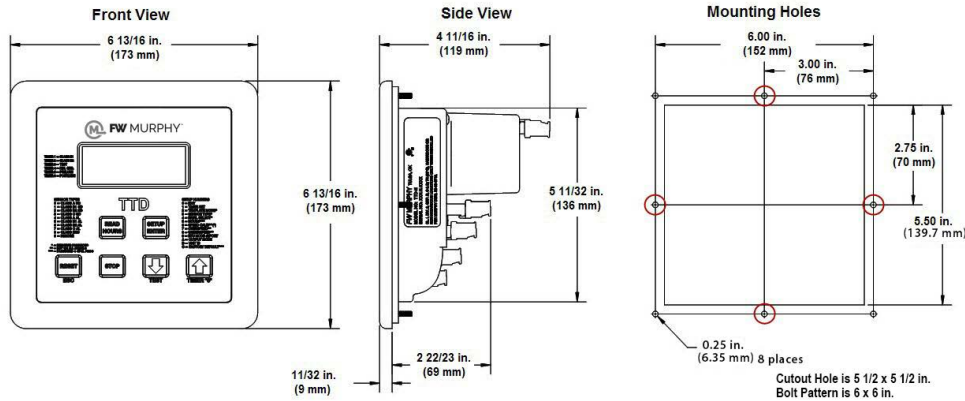

## Power Supply (PSU-2)

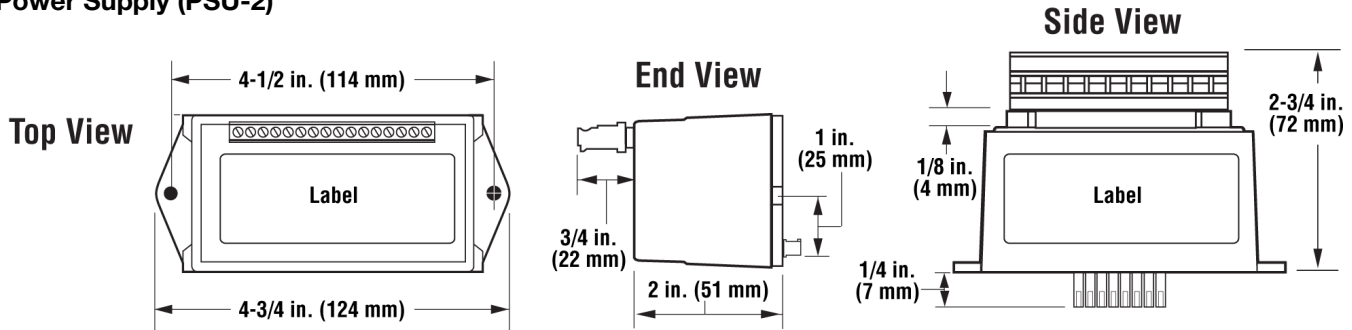

## TTD System

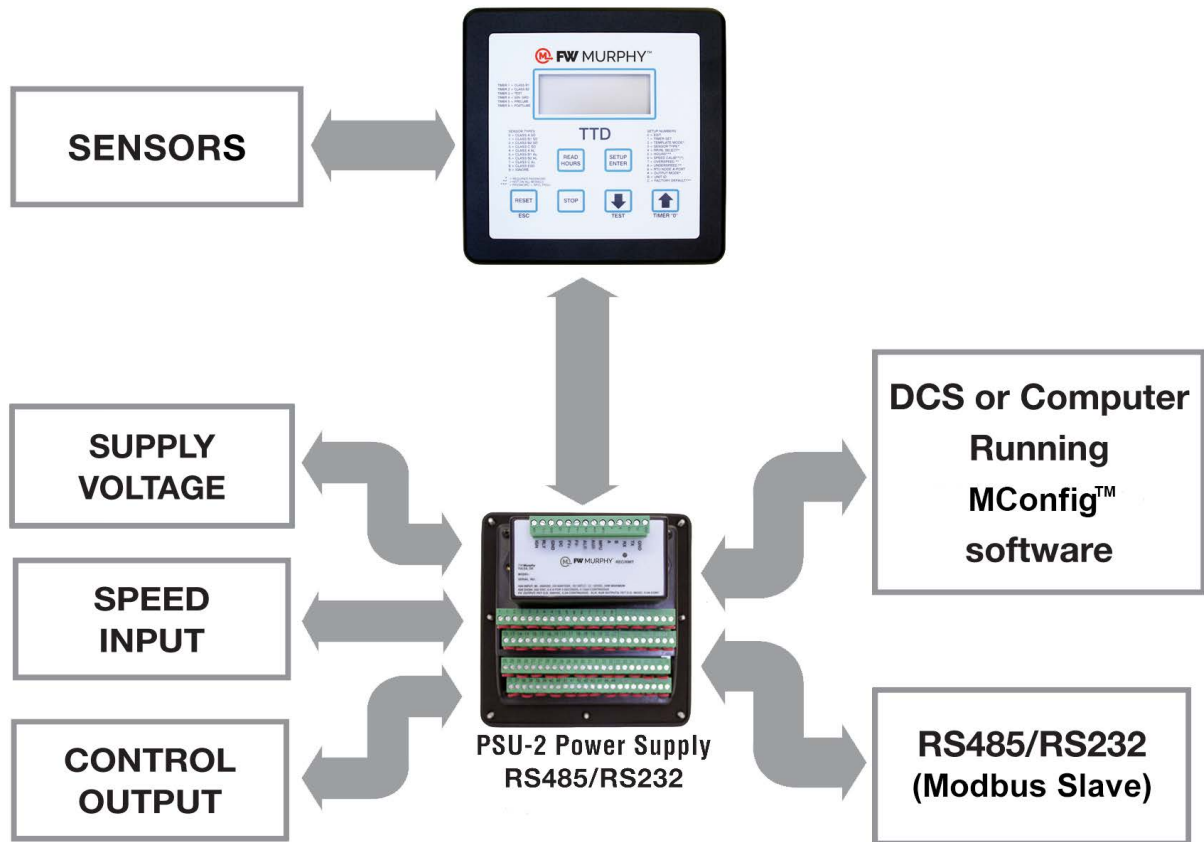

## TTD-H Display Head



Normal Operation Display  
(yellow background\*)



Shutdown/Warning Display  
(red background\*)



Back View w/PSU-2

## TTD Intuitive Display Icons

The TTD system features a static LCD (A) with backlight (external DC is required). The applicable icon and number (B, C and D) will be displayed to clarify the display readings or alert the operator to an operating condition.

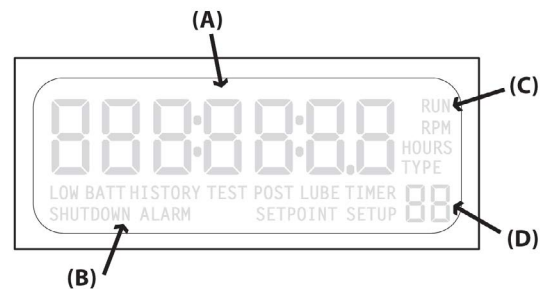

# How to Order

Options listed below. All configurations may not be available. Call your sales representative or FW Murphy for more information.

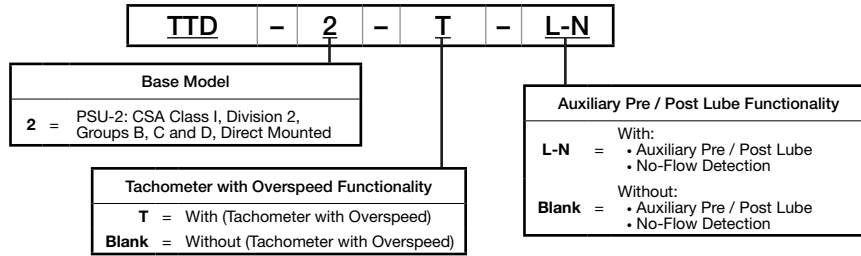

	2	T	L-N
<b>TTD-2</b>	X		
<b>TTD-2-T</b>	X	X	
<b>TTD-2-L-N</b>	X		X
<b>TTD-2-T-L-N</b>	X	X	X

Approximate Shipping Weight and Dimensions		
Model	Weight	Dimension
TTD-2	5 lb. 4 oz.	15 x 15 x 15 in.
TTD-2-T	5 lb. 1 oz.	10 x 12 x 12-1/4

Part Number	Description	Notes
50700597	TTD-H Display Head	Replacement Parts and Assemblies
50700596	PSU-2 Div 2 Power Supply	
50700594	PSU-2-T Div 2 Power Supply w/ Tach	
50700944	PSU-2-L-N Div 2 Power Supply w/Pre/Post Lube and No-Flow	
50700942	PSU-2-T-L-N Div 2 Power Supply w/ Tach, Pre/Post Lube and No-Flow	
00005125	Backup Lithium Battery, 6VCD, 1200mAh	
50000774	Ignition Choke Filter	

Approximate Shipping Weight and Dimensions		
Model	Weight	Dimension
TTD-H Display Head	2 lbs. 4oz.	8 x 8 x 8 in.
All PSU Div 2 Power Supply	7 oz.	5 x 5 x 3 in.