

Series QCT and QCB cylinders with integrated guide

Double-acting, magnetic piston, guided
 ø 20, 25, 32, 40, 50, 63 mm



- » Magnetic sensors can be mounted on both sides
- » QCT: bronze bushings version
- » QCB: ball bearing guide version
- » Movement and guidance in one unit

These actuators, suitable for use in very limited space, are available in two versions.
QCT version: with sintered bronze bushes, suitable when the side loads applied to the cylinder are high.
QCB version: with linear ball bearings, suitable for high precision and fast cycling applications.

Both versions are equipped with fixed cushioning to prevent direct impact with the end covers. The design of the cylinder body allows the mounting of the cylinder using either top, bottom or side faces. Several "T" shaped grooves in two faces allow sensors to be fitted in a number of positions. Out of standard strokes are available on demand only.

GENERAL DATA

Type of construction	compact guided QCT = sintered bronze bushes QCB = linear ball bearings
Operation	double-acting
Materials	body = anodized AL flange = zinc-plated steel piston rod = rolled stainless steel AISI 303 QCT columns = rolled stainless steel 420B QCB columns = hardened steel C50 seals = PU
Mounting	threaded and non-threaded holes in the body
Strokes min. max	see table
Operating temperature	0°C ÷ 80°C (with dry air - 20°C)
Speed	50 ÷ 500 mm/s
Operating pressure	1 ÷ 10 bar
Fluid	clean air, non lubricated. If lubricated air is used, it is recommended to use oil ISOVG32. Once applied the lubrication should never be interrupted.

STANDARD STROKES FOR DOUBLE-ACTING CYLINDERS SERIES QC

■ = Double-acting
 Out of standard intermediate strokes available on request (strokes multiple of 5 mm)

STANDARD STROKES											
∅	20	25	30	40	50	75	100	125	150	175	200
20	■		■	■	■	■	■	■	■	■	■
25	■		■	■	■	■	■	■	■	■	■
32		■			■	■	■	■	■	■	■
40		■			■	■	■	■	■	■	■
50		■			■	■	■	■	■	■	■
63		■			■	■	■	■	■	■	■

CODING EXAMPLE

QC	T	2	A	020	A	050
QC	SERIES					
T	VERSION: T = sintered bronze bushes B = linear ball bearings					
2	OPERATION: 2 = double-acting				PNEUMATIC SYMBOLS CD07	
A	MATERIALS: A = anodized aluminium body - rolled stainless steel AISI 303 piston rod rolled stainless steel AISI 420B columns for QCT - hardened steel C50 columns for QCB					
020	BORE: 020 = 20 mm - 025 = 25 mm - 032 = 32 mm - 040 = 40 mm - 050 = 50 mm - 063 = 63 mm					
A	TYPE OF DESIGN: A = standard					
050	STROKE (see the table)					

PNEUMATIC SYMBOLS

The pneumatic symbols which have been indicated in the CODING EXAMPLE are shown below.



TABLE OF PERMISSIBLE LOADS (F)

For sintered bronze bushes
QCT version
For linear ball bearings
QCB version

F (N) 1N = 0.102 kgf
Ex.: QCT2A025A020 = F = 140N

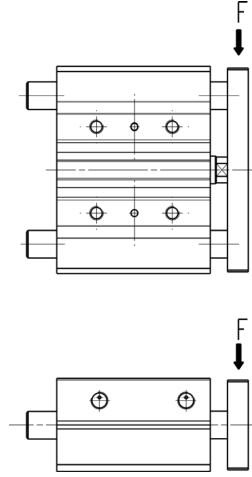

STROKE		20	25	30	40	50	75	100	125	150	175	200
20	QCT	100	-	93	81	73	114	93	98	85	75	67
25	QCT	140	-	120	115	103	165	135	150	131	116	104
32	QCT	-	253	-	-	214	225	208	225	198	176	159
40	QCT	-	251	-	-	197	215	206	224	196	175	157
50	QCT	-	317	-	-	273	267	299	257	225	200	179
63	QCT	-	316	-	-	273	267	299	257	225	200	179
20	QCB	110	-	100	125	121	90	86	69	58	49	43
25	QCB	142	-	85	154	148	106	82	97	81	70	61
32	QCB	-	222	-	-	91	167	129	145	122	104	90
40	QCB	-	221	-	-	93	167	128	145	121	104	90
50	QCB	-	203	-	-	152	161	193	156	130	110	95
63	QCB	-	201	-	-	151	158	195	157	130	110	94

TABLE OF PERMISSIBLE MOMENTS (M)

For sintered bronze bushes
QCT version
For linear ball bearings
QCB version

M (N*m) 1N*m = 0,102 kgf *m
Ex.: QCT2A025A020 = M = 3,4 Nm

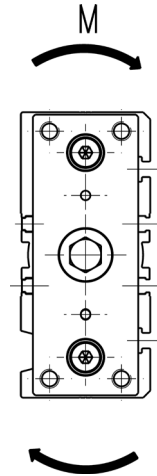

STROKE		20	25	30	40	50	75	100	125	150	175	200
20	QCT	1,7	-	1,5	1,2	1,0	2,9	2,8	2,6	2,3	2,0	1,8
25	QCT	3,4	-	2,9	3,6	3,3	4,2	4,3	3,8	3,2	2,7	2,3
32	QCT	-	6,7	-	-	6,5	7,2	7,0	6,6	5,6	4,8	4,1
40	QCT	-	8,7	-	-	7,3	9,2	8,8	9,6	8,4	7,5	6,7
50	QCT	-	15,4	-	-	12,9	12,6	13,4	12,1	11,3	10,7	8,8
63	QCT	-	15,1	-	-	14,3	16,6	17	14	11,3	9,7	9,1
20	QCB	3,0	-	2,7	3,4	3,3	2,4	2,3	1,9	1,6	1,3	1,2
25	QCB	3,5	-	2,7	4,9	4,7	3,4	2,6	3,1	2,6	2,2	2,0
32	QCB	-	6,3	-	-	3,6	6,5	5,1	5,7	4,8	4,1	3,5
40	QCB	-	8,5	-	-	4,0	7,2	5,5	6,2	5,2	4,5	3,9
50	QCB	-	11,1	-	-	8,3	8,8	10,6	8,6	7,1	6,0	5,2
63	QCB	-	8,3	-	-	7,2	9,8	12,1	9,7	8,1	6,8	5,8

Cylinders Series QC



Note: for out of standard intermediate strokes (ex. stroke 35), consider the immediately higher stroke dimensions (ex. stroke 40).

For $\emptyset C$, B, L3 dimensions, see the following page.

+ = add the stroke

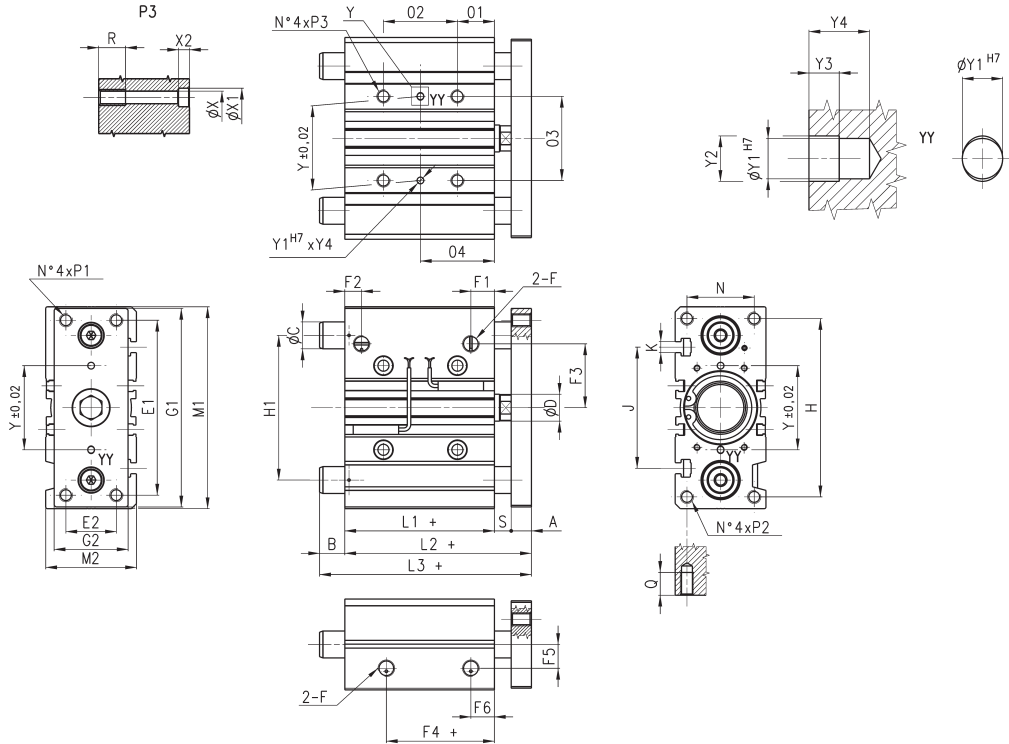

In case of use of lateral ports, unscrew the related threaded caps, screw them in the front ports and tighten them up to the cylinder surface (not tighter) having care to use a proper sealer.

DIMENSIONS													
Dimension O2 (mm)	Ø 20	Ø 25	Ø 32	Ø 40	Ø 50	Ø 63	Dimension O4 (mm)	Ø 20	Ø 25	Ø 32	Ø 40	Ø 50	Ø 63
20 ÷ 30	24	24	24	24	24	28	20 ÷ 30	29	29	33	34	36	38
40 ÷ 100	44	44	48	48	48	52	40 ÷ 100	39	39	45	46	48	50
125 ÷ 200	120	120	124	124	124	128	125 ÷ 200	77	77	83	84	86	88

DIMENSIONS																																					
Ø	A	ØD	E1	E2	F	F1	F2	F3	F4	F5	F6	G1	G2	H	H1	L1	L2	M1	M2	N	O1	O3	P1/P2	P3	Q	R	S	Y	Y1	Y2	Y3	Y4	X	X1	X2	J	K
20	10	10	70	18	G1/8	10.5	10.5	25	12.5	11.5	10.5	81	30	72	54	37	53	83	36	24	17	28	M5X0.8	M6X1	13	12	6	28	3	3.5	3	6	5.5	9	5	44	M5
25	10	12	78	26	G1/8	11.5	8	28.5	12.5	13.5	11.5	91	40	82	64	37.5	53.5	93	42	30	17	34	M6X1	M6X1	15	12	6	34	4	4.5	3	6	5.5	9	5	50	M5
32	12	16	96	30	G1/8	12.5	9.5	34	7	15	12.5	110	45	98	78	37.5	59.5	112	48	34	21	42	M8X1.25	M8X1.25	20	16	10	42	4	4.5	3	6	6.5	11	6.5	63	M6
40	12	16	104	30	G1/8	13	12	38	13	18	13	118	45	106	86	44	66	120	54	40	22	50	M8X1.25	M8X1.25	20	16	10	50	4	4.5	3	6	6.5	11	6.5	72	M6
50	15	20	130	40	G1/4	14	11	47	8	21.5	12	146	60	130	110	44	72	148	64	46	24	66	M10X1.5	M10X1.5	22	20	13	66	5	6	4	8	8.5	14	8.5	92	M8
63	15	20	130	50	G1/4	14.5	11.4	55	12	28	14.5	158	70	142	124	49	77	162	78	58	24	80	M10X1.5	M10X1.5	22	20	13	80	5	6	4	8	8.5	14	8.5	110	M10

SERIES QC CYLINDERS

QCB: total length (L3), projection (B) and guide columns Ø (ØC)



Note: for out of standard intermediate strokes (ex. stroke 35), consider the immediately higher stroke dimensions (ex. stroke 40). Standard strokes can be found in the dedicated table on page 4.05.02.

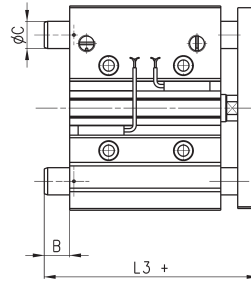

Dimensions L3 and B change according to the different strokes of QCB.

DIMENSIONS															
Ø	L3 (strokes 20-30 mm)	L3 (strokes 25-50 mm)	L3 (strokes 25-75 mm)	L3 (strokes 40-100 mm)	L3 (strokes 75-100 mm)	L3 (strokes 100-200 mm)	L3 (strokes 125-200 mm)	B (strokes 20-30 mm)	B (strokes 25-50 mm)	B (strokes 25-75 mm)	B (strokes 40-100 mm)	B (strokes 75-100 mm)	B (strokes 100-200 mm)	B (strokes 125-200 mm)	ØC
20	72	-	-	75	-	-	85	19	-	-	22	-	-	32	10
25	74.5	-	-	85.5	-	-	98	21	-	-	32	-	-	44.5	12
32	-	86	-	-	95	-	110	-	26.5	-	-	35.5	-	50.5	16
40	-	86	-	-	95	-	110	-	20	-	-	29	-	44	16
50	-	-	93	-	-	112	-	-	-	21	-	-	40	-	20
63	-	-	93	-	-	112	-	-	-	16	-	-	35	-	20

QCT: total length (L3), projection (B) and columns Ø (ØC)



Note: for out of standard intermediate strokes (ex. stroke 35), consider the immediately higher stroke dimensions (ex. stroke 40). Standard strokes can be found in the dedicated table on page 4.05.02.

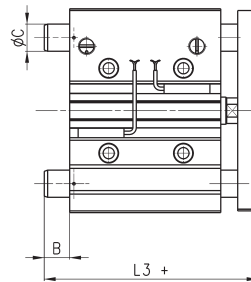

Dimensions L3 and B change according to the different strokes of QCT.

DIMENSIONS															
Ø	L3 (strokes 20-50 mm)	L3 (stroke 20 mm)	L3 (stroke 25 mm)	L3 (strokes 30-50 mm)	L3 (strokes 25-200 mm)	L3 (strokes 75-200 mm)	L3 (strokes 50-200 mm)	B (strokes 20-50 mm)	B (stroke 20 mm)	B (stroke 25 mm)	B (strokes 30-50 mm)	B (strokes 25-200 mm)	B (strokes 75-200 mm)	B (strokes 50-200 mm)	ØC
20	74.5	-	-	-	-	79.5	-	21.5	-	-	-	-	26.5	-	12
25	-	74.5	-	80.5	-	85	-	21	-	27	-	-	31.5	-	16
32	-	-	73.5	-	-	-	91.5	-	-	14	-	-	-	32	20
40	-	-	73.5	-	-	-	91.5	-	-	7.5	-	-	-	25.5	20
50	-	-	-	-	98.5	-	-	-	-	-	-	26.5	-	-	25
63	-	-	-	-	98.5	-	-	-	-	-	-	21.5	-	-	25