

EXPLORE[®] SCIENTIFIC

EXOSPF and Adapter Instruction Manual

Item #: PFiEXOS100



WARNING:

The lens contains lead that may be harmful.
Wash hands after touching.



x2
INCLUDED



WARNING:

This product can expose you to lead, which is known to the State of California to cause cancer and birth defects or other reproductive harm. For more information go to www.P65Warnings.ca.gov.



WARNING:

Contains button or coin cell battery.
Hazardous if swallowed



WARNING: SUN HAZARD – Never look directly at the sun with this device.

DO NOT USE THIS TELESCOPE OR ANY ACCOMPANYING FINDER SCOPE TO LOOK AT OR NEAR THE SUN UNLESS YOU ARE USING A SPECIAL SOLAR FILTER! EVEN MOMENTARY VISUAL CONTACT WITH THE SUN'S LIGHT RAYS CAN INSTANTLY CAUSE IRREVERSIBLE DAMAGE TO YOUR EYE(S). EYE DAMAGE CAN BE PAINLESS, SO THERE IS NO WARNING TO THE OBSERVER THAT DAMAGE HAS OCCURRED UNTIL IT IS TOO LATE. TAKE EXTRA CARE WHEN USING THE TELESCOPE OR A FINDER SCOPE DURING DAYLIGHT HOURS, AND DO NOT POINT EITHER AT OR NEAR THE SUN. DO NOT LOOK THROUGH EITHER WHEN YOU ARE MOVING THE INSTRUMENTS DURING THE DAYTIME. NEVER ALLOW ANYONE TO USE THE TELESCOPE OR A FINDER SCOPE DURING THE DAYTIME WITHOUT WARNING THEM OF THE HAZARDS OF AIMING EITHER AT OR NEAR THE SUN. MAKE SURE THAT THEY ARE ADEQUATELY TRAINED ON THE USE OF THESE INSTRUMENTS BEFORE ALLOWING THEM TO START OBSERVING. CHILDREN SHOULD ALWAYS HAVE INFORMED AND TRAINED ADULT SUPERVISION WHILE OBSERVING.

⚠ IMPORTANT SAFETY INSTRUCTIONS

READ AND FOLLOW THE INSTRUCTIONS BEFORE USE. KEEP THESE INSTRUCTIONS FOR LATER USE.



• **SUN WARNING: WARNING – NEVER ATTEMPT TO OBSERVE THE SUN WITH THIS DEVICE! OBSERVING THE SUN – EVEN FOR A MOMENT – WILL CAUSE INSTANT AND IRREVERSIBLE DAMAGE TO YOUR EYE OR EVEN BLINDNESS.** EYE DAMAGE IS OFTEN PAINLESS, SO THERE IS NO WARNING TO THE OBSERVER THAT THE DAMAGE HAS OCCURRED UNTIL IT IS TOO LATE. DO NOT POINT THE DEVICE AT OR NEAR THE SUN. DO NOT LOOK THROUGH THE DEVICE AS IT IS MOVING. CHILDREN SHOULD ALWAYS HAVE ADULT SUPERVISION WHILE OBSERVING.

• **RESPECT PRIVACY:** WHEN USING THIS DEVICE, RESPECT THE PRIVACY OF OTHER PEOPLE. FOR EXAMPLE, DO NOT USE IT TO LOOK INTO PEOPLE'S HOMES.



• **CHOKING HAZARD:** CHILDREN SHOULD ONLY USE DEVICE UNDER ADULT SUPERVISION. KEEP PACKAGING MATERIALS LIKE PLASTIC BAGS AND RUBBER BANDS OUT OF THE REACH OF CHILDREN AS THESE MATERIALS POSE A CHOKING HAZARD.

• **RISK OF BLINDNESS:** NEVER USE THIS DEVICE TO LOOK DIRECTLY AT THE SUN OR IN THE DIRECT PROXIMITY OF THE SUN. DOING SO MAY RESULT IN A PERMANENT LOSS OF VISION.

• **RISK OF FIRE:** DO NOT PLACE DEVICE, PARTICULARLY THE LENSES, IN DIRECT SUNLIGHT. THE CONCENTRATION OF LIGHT RAYS COULD CAUSE A FIRE.

• **DO NOT SUBJECT THE DEVICE TO TEMPERATURES EXCEEDING 60 °C (140 °F).**



• **DISPOSAL:** KEEP PACKAGING MATERIALS, LIKE PLASTIC BAGS AND RUBBER BANDS, AWAY FROM CHILDREN AS THEY POSE A RISK OF SUFFOCATION. DISPOSE OF PACKAGING MATERIALS AS LEGALLY REQUIRED. CONSULT THE LOCAL AUTHORITY ON THE MATTER IF NECESSARY AND RECYCLE MATERIALS WHEN POSSIBLE.



• THE WEEE SYMBOL IF PRESENT INDICATES THAT THIS ITEM CONTAINS ELECTRICAL OR ELECTRONIC COMPONENTS WHICH MUST BE COLLECTED AND DISPOSED OF SEPARATELY.

• NEVER DISPOSE OF ELECTRICAL OR ELECTRONIC WASTE IN GENERAL MUNICIPAL WASTE. COLLECT AND DISPOSE OF SUCH WASTE SEPARATELY.

• MAKE USE OF THE RETURN AND COLLECTION SYSTEMS AVAILABLE TO YOU, OR YOUR LOCAL RECYCLING PROGRAM. CONTACT YOUR LOCAL AUTHORITY OR PLACE OF PURCHASE TO FIND OUT WHAT SCHEMES ARE AVAILABLE.

• ELECTRICAL AND ELECTRONIC EQUIPMENT CONTAINS HAZARDOUS SUBSTANCES WHICH, WHEN DISPOSED OF INCORRECTLY, MAY LEAK INTO THE GROUND. THIS CAN CONTRIBUTE TO SOIL AND WATER POLLUTION WHICH IS HAZARDOUS TO HUMAN HEALTH, AND ENDANGER WILDLIFE.

• IT IS ESSENTIAL THAT CONSUMERS LOOK TO RE-USE OR RECYCLE ELECTRICAL OR ELECTRONIC WASTE TO AVOID IT GOING TO LANDFILL SITES OR INCINERATION WITHOUT TREATMENT.



BUTTON/COIN BATTERY WARNING: THIS PRODUCT CONTAINS A BUTTON OR COIN CELL BATTERY. A SWALLOWED BUTTON OR COIN CELL BATTERY CAN CAUSE INTERNAL CHEMICAL BURNS IN AS LITTLE AS TWO HOURS AND LEAD TO DEATH. DISPOSE OF USED BATTERIES IMMEDIATELY. KEEP NEW AND USED BATTERIES AWAY FROM CHILDREN. IF YOU THINK BATTERIES MIGHT HAVE BEEN SWALLOWED OR PLACED INSIDE ANY PART OF THE BODY, SEEK IMMEDIATE MEDICAL ATTENTION.

• A SWALLOWED BUTTON OR COIN CELL BATTERY CAN CAUSE INTERNAL CHEMICAL BURNS IN AS LITTLE AS TWO HOURS AND LEAD TO DEATH DUE TO CHEMICAL BURNS AND POTENTIAL PERFORATION OF THE ESOPHAGUS.

• DISPOSE OF USED BATTERIES IMMEDIATELY, FLAT/DRAINED BATTERIES CAN STILL BE DANGEROUS

• KEEP NEW AND USED BATTERIES AWAY FROM CHILDREN.

• IF YOU THINK BATTERIES MIGHT HAVE BEEN SWALLOWED OR PLACED INSIDE ANY PART OF THE BODY, SEEK IMMEDIATE MEDICAL ATTENTION.

• IF YOU SUSPECT YOUR CHILD HAS SWALLOWED OR INSERTED A BUTTON BATTERY IMMEDIATELY CALL THE POISONS CONTROL HOTLINE AND SEEK IMMEDIATE MEDICAL ATTENTION.

• EXAMINE DEVICES AND MAKE SURE THE BATTERY COMPARTMENT IS CORRECTLY SECURED, E.G. THAT THE SCREW OR ANOTHER MECHANICAL FASTENER IS TIGHTENED. DO NOT USE IF COMPARTMENT IS NOT SECURE.

• TELL OTHERS ABOUT THE RISK ASSOCIATED WITH BUTTON BATTERIES AND HOW TO KEEP THEIR CHILDREN SAFE.

Parts Overview

Parts List

1. Polar Finderscope with Illuminated Reticle
2. Illuminator
3. Illuminator ON/OFF and Brightness Adjustment
4. Pivot Collar with Three Collimation Screws
5. Polar Finderscope Bracket
6. Attachment Bolt
7. Mount Adapter Plate
8. Eyepiece
9. 2x M2.5 x 20mm long screws

Tools Needed

(Not Included):

- 2mm Hex Wrench
- 4mm Hex Wrench
- Small Phillips Screwdriver

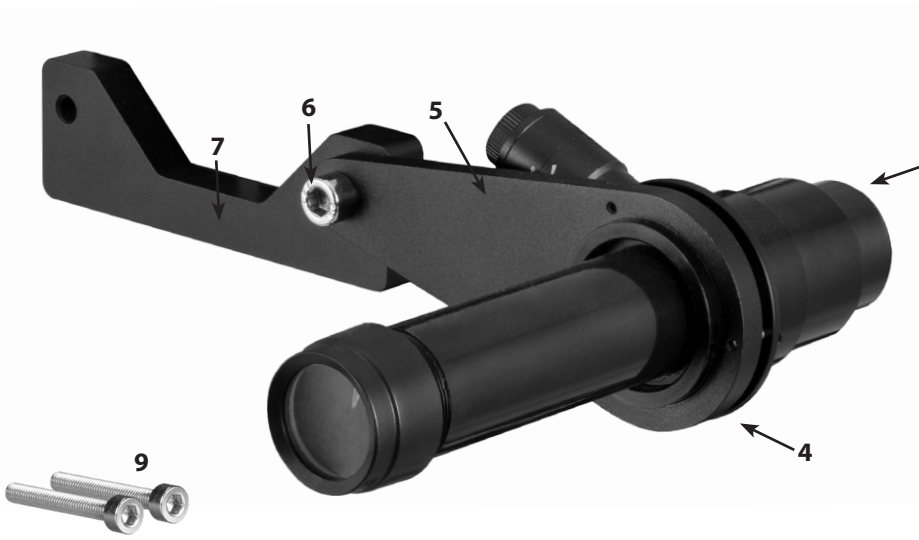

Assembly

Illuminated Polar Finderscope

A casual alignment with the celestial pole is sufficient for visual purposes. However, for observers who need to meet the demanding requirements of astrophotography, this polar finderscope allows the iEXOS-100 mount to be more precisely aligned with the celestial pole.

How to Install and Use the Adapter & Illuminated Polar Alignment Finderscope:

1. Remove the polar finderscope assembly from the packaging, and separate the adapter (#7) from the polar finderscope bracket (#5) by removing the attachment bolt (#6) with a 4mm hex wrench (not included).
2. As shown in Figure 1, remove the two screws in the front of the declination drive's cover using a 2mm hex wrench (not included).
3. As shown in Figure 2A, align the adapter (#7) with the openings left by the removed screws. Using the M2.5 x 20mm long screws (#9), attach the mount adapter plate as shown in Figure 2B.



Assembly

4. As shown in Figure 3, focus the polar finderscope (#1) by looking through the finderscope at an object that is at least 1 mile away. If the image is not sharp, look through the finderscope while turning the eyepiece (#8) until the image is sharp.



5. As shown in Figure 4, attach the polar finderscope bracket (#5) to the mount adapter plate (#7) using the attachment bolt (#6) that was removed in the first step. Adjust the position of the polar finderscope so that it is in a comfortable observing position. Tighten the bolt.

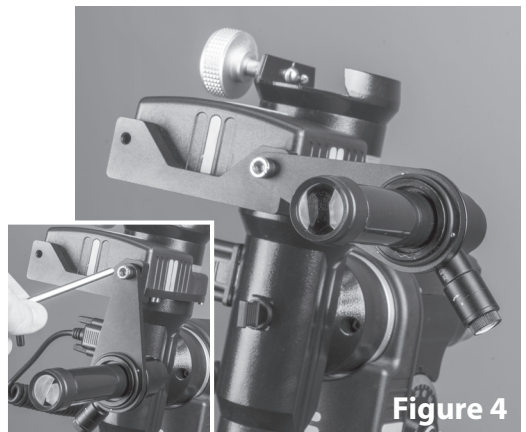

6. As shown in Figure 5, the disc with the knurled edge (#3) is used to turn the illuminator on and off and to adjust the brightness. It also covers the battery compartment.



Polar Alignment Process

Prior to using the polar finderscope to locate objects in the night sky, you will need to make sure it is aligned with your mount. This process is best done during the day.

***NOTE:** Please refer to the iEXOS-100 PMC-Eight Manual as needed to identify the parts of the mount referenced in the following procedure.*

1. Remove the telescope or camera/lens system from the mount if this has not been done already. Once the instruments are removed, loosen the declination clutch (Figure 6.1) and turn the declination axis to 90°. Tighten the clutch.
2. Remove the cover of the iEXOS-100 mount's polar peephole (Figure 6.2).
3. Adjust the mount's latitude adjustment handle (Figure 6.3) so that you can see a land object that is at least 1 mile away. Looking through the peephole on the polar axis (Figure 6.4), center the view on a distinct feature -- such as the top of a power pole or the peak of a house.
4. Look through the polar finderscope to see if the view is centered on the same land feature as what is in the center of the polar peephole.
5. Loosen the right ascension clutch (Figure 6.5). Rotate the mount around the RA axis, while look through the polar finderscope. If the object stays centered in the view, no adjustments to the polar finderscope are necessary. If the object does not stay centered in the finderscope, perform steps 6 and 7.
6. To align the polar finderscope with the mount, make small adjustments to one or more of the three collimation screws located in the pivot collar. Using a small Phillips screwdriver (not included) carefully adjust the screws in the opposite direction of where the finder needs to move. Always make slight adjustments to avoid overcorrecting. Do not tighten the screws so tight that the polar finderscope cannot rotate in the pivot collar.
7. Check the alignment again by repeating step 5.

Polar Alignment Process

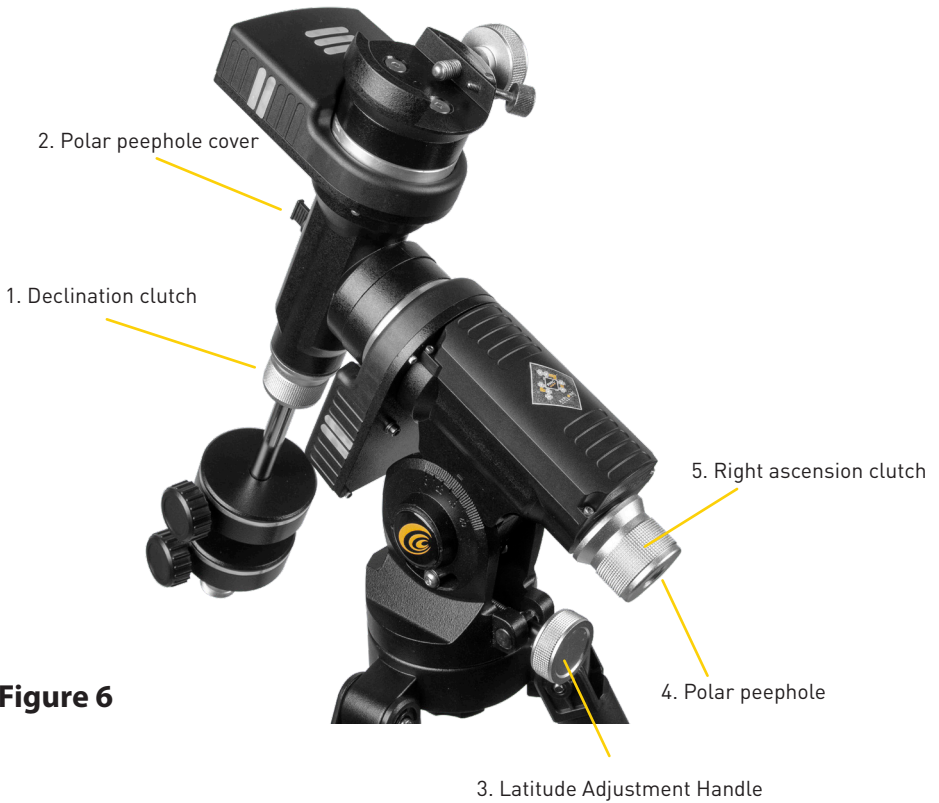

Figure 6

8. Repeat steps 5 and 6 until the image remains stationary in the polar finderscope while rotating the right ascension axis.

9. For final alignment, perform steps 5 and 6 on a bright star.

Notes



explorescientific.com

©2020 Explore Scientific, LLC. All model names and logos are registered trademarks.