



marey®

ECO180 | ECO270

ELECTRIC TANKLESS WATER HEATER

**INSTRUCTIONAL
MANUAL**



Keep this manual with you after your unit has been installed, you may need it for further technical information.

📞 USA (855) 627-3955

🌐 www.Marey.com

📞 PR (787) 727-0277



Congratulations! You've just purchased a new Marey ECO tankless water heater and will soon begin to enjoy the benefits of "going tankless."

Please take the time to thoroughly read and understand this safety and installation manual in its entirety before you attempt to install your new tankless water heater, as it contains important safety tips and instructions.

Please carefully read all instructions and warnings. Should you have any questions, please visit www.marey.com for installation videos and FAQ.

Please keep this manual for future reference and technical information.





INDEX

QUICK START GUIDE	04
WARNING	05
IMPORTANT WARNINGS	05
IMPORTANT SAFETY INFORMATIONS	05
PRODUCT FEATURES	06
PRODUCT ADVANTAGES	07
INSTALLATION DIAGRAM	07
TECHNICAL SPECIFICATION REQUIREMENTS	09
PRODUCT INNER STRUCTURE	10
INSTALLATION GUIDELINE	11
TROUBLE-SHOOTING/DIAGNOSTIC CHART	19
ELECTRICAL DIAGRAM	21
CUSTOMER SERVICE	23



ECO180 | 270

1) Mounting

Mount vertically on a flat surface (i.e. board or wall) larger than the unit itself. Make sure bracket is secure by utilizing a stud or the provided wall anchors. Keep away from any potential splashing or leaking water and strong magnetic fields.

2) Water Connections

When installing your water connections make sure to use $\frac{3}{4}$ " NPT fittings. Please use the provided gaskets to prevent leaks. When tightening fittings use a back-up wrench on inlet and outlet fittings (flat sides of fittings are located behind front cover). It is recommended to install a high pressure discharge valve and a shut off valve on the incoming water line, in that order. Open a faucet and run water through the unit for a few minutes to purge out air, turn off at faucet to build up pressure in the line to check for leaks.

3) Electrical Connections

Wiring for electrical connection will differ depending on model please double check the model type on the right side of the unit.



4) Operation

Unit is activated by the flow of water through the inlet. A desired temperature set point is selected by using the "up" or "down" buttons, if unit does not respond push the center "power" button and try again. Test water to prevent scalding.



WARNING

If your water heater requires a reset, be sure to **TURN OFF THE BREAKERS** prior to resetting the unit.

Resetting your unit without turning off the breakers can result in personal injury and damage to your water heater.

WARNING! There is water contained in the coils of your water heater at all times. If your water heater is exposed to freezing temperatures, the water in the coils could freeze, causing a break in the heat exchanger of the unit, or the supply and return lines. This kind of damage will result in water running freely into the space where the water heater is located, which can cause flooding. **DO NOT** install this water heater where it may be subjected to a freeze. If your water heater is in an area where freezing is a possibility, you must turn off the water to the heater and drain it of any water by disconnecting the water lines. Leave the water lines disconnected until you intend to use the water heater.



IMPORTANT WARNINGS

This is not a do-it-yourself project. If you are not familiar with basic plumbing and electricity, we strongly recommend that this water heater be installed by a licensed plumber and/or electrician.

Installation of this product is restricted to indoor locations.

Under no circumstances should you attempt to install, repair or disassemble the Marey Heater tankless electric water heater without first shutting off all power to the unit directly at the circuit breaker panel.



IMPORTANT SAFETY INFORMATION

- 1) The installation must be in compliance with your local electrical and plumbing codes.
- 2) This water heater must be **GROUND**ED.
- 3) All wiring and installation must be supervised by a qualified electrician.
- 4) **CAUTION:**This product has more than one power-supply connection point. Discon-nect all power supplies before servicing.
- 5) This water heater is not intended for use by persons (including children) with reduced physical, sensory or mental capabilities, or lack of experience or knowledge, unless they have been given supervision or instruction concerning the use of the water heater by a person responsible for their safety. Children should be supervised to ensure that they do not play with the water heater.

6. This water heater **MUST** be permanently connected to a fixed circuit breaker.
7. **DO NOT** install this water heater near volatile or flammable substances, near tinder wood or near a strong magnetic field.
8. **DO NOT** switch the heater on if you suspect that it may be frozen. Wait until you are sure that it has completely thawed out.
9. Before taking a shower, feel the outlet hot water temperature with your hand to make sure it is suitable for showering to avoid getting scalded.
10. Before connecting the water heater hoses to the plumbing in your home, it is extremely important to **FLUSH** the lines to wash out any plumbing paste or residue in the lines.
11. The heating chamber is treated with composite nano-insulation material. It is normal for there to be a slight odor and possibly a small amount of green/blue smoke when the unit is used for the first time.
12. If there is damage to the wiring or any internal part, you must contact a qualified electrician to replace it, or send it to one of our service centers for repair. (Replacement parts are available from Marey.)
13. The shower head should be cleaned and checked periodically for debris and build-up.
14. This water heater must be installed vertically, per the mounting instructions.



PRODUCT FEATURES

1. Energy efficient, instantaneous heating on demand. It's tankless, so no preheating and no stand-by heat loss, which saves even more energy.
2. Micro-computer controlled, patented heating technology.
3. Extremely safe! Water is completely separated from electricity by multi-layers of composite nano-insulation material, and the heater contains multiple additional safety devices, as outlined below.
4. Over-heating reaches 153° F / 67°C, the electricity is automatically cut off. If this occurs, the screen hermal cut-off to avoid scalds. When the outlet water temperature beeps and displays an E1 code.

- 5. Malfunction sensor. If there is a malfunction with the temperature sensor, the heater stops working and the screen displays an E3 code.
- 6. Dry-heating thermal cut-off. In case of dry heating, the electricity will be cut off and the screen display will display an E4 code.
- 7. Micro-computer features an automatic electricity and water consumption calculating function.

PRODUCT ADVANTAGES



Fig. 01

Marey heating elements are made from a single piece of cast aluminum, so there will never be water leakage non electric leakage in the heating chamber. Marey heaters also have an extra stainless steel water flow channel instead of the previous layered plate style, so no matter how your water quality is inside the heating element, it will provide a long life of service.

INSTALLATION DIAGRAM

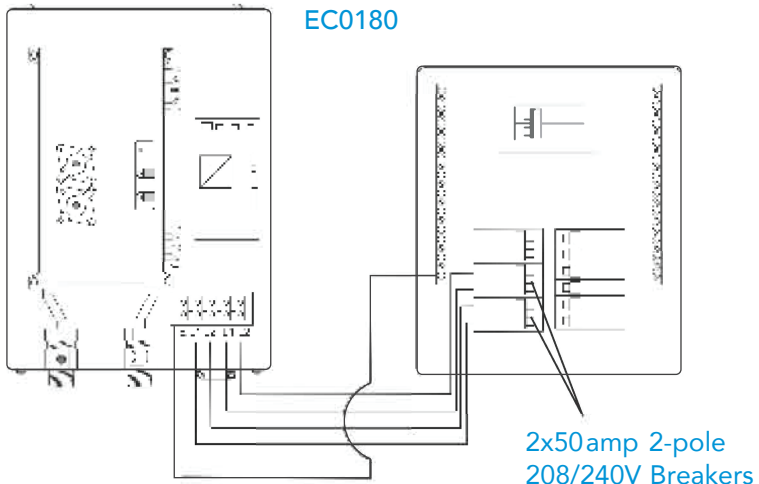

Fig. 02

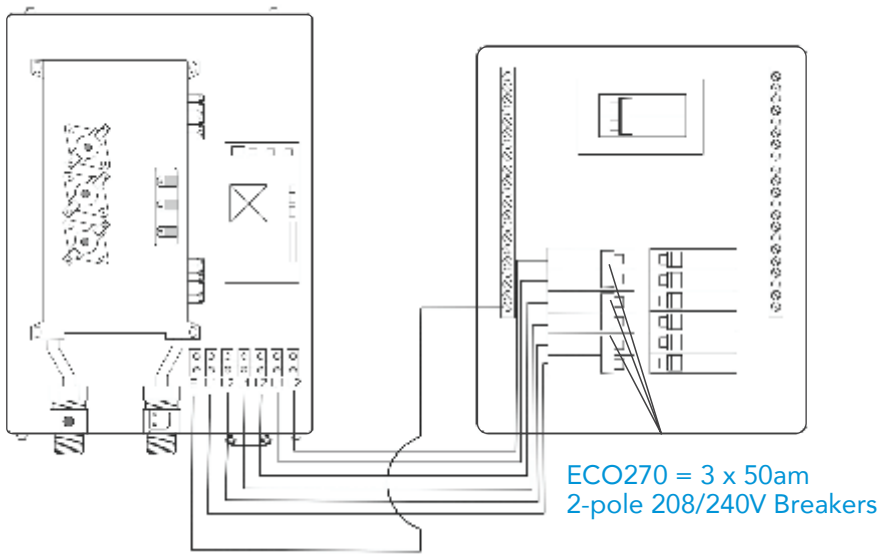

Fig. 03

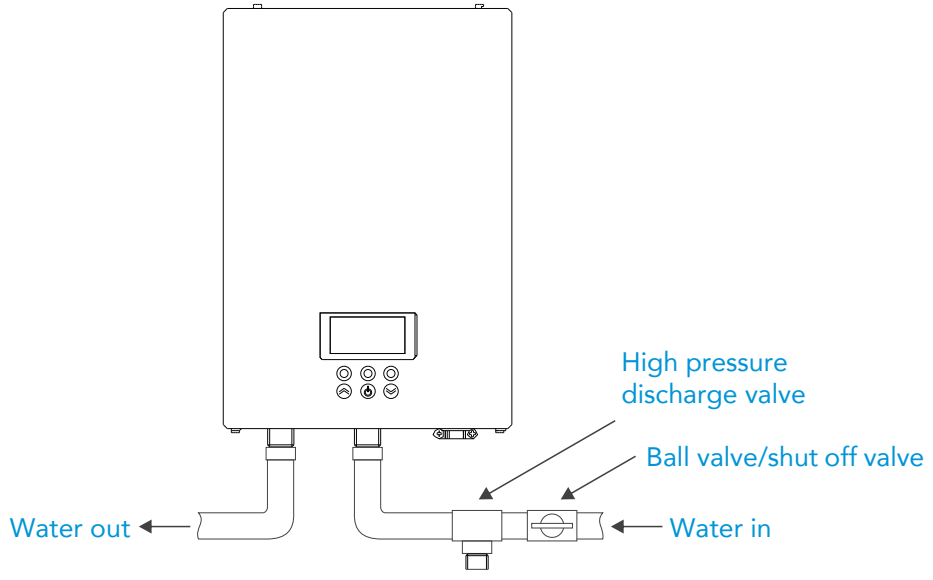

Fig. 04

TECHNICAL SPECIFICATIONS AND INSTALLATION REQUIREMENTS

PRODUCT CODE	ECO180	ECO270
Energy	18kW	27kW
Minimum Required Circuit Breaker	2x50A	3x50A
Max. Amp. Load	75A	112.5A
Min. Wire Size	2x6 AWG Copper	3x6 AWG Copper
Voltage/Frequency	240V, 60Hz	
Water Connections	3/4" NPT	
Recommended Min. Flow Activation	0.85 GPM / 3.2 L/min	
Safe Operating Pressure	5 PSI - 85 PSI	
Dimensions	11.0" x 16.1" x 3.5"	
Weight	17.7 lbs	18.3 lbs

ECO180



ECO270



*Wire gauge varies by amperage and distance; must contact electrician if you are not sure.

Temp. Increase per GPM		
	ECO180	ECO270
1.0	103°F	184°F
1.5	82°F	123°F
2.0	61°F	92°F
2.5	49°F	74°F
3.0	41°F	61°F
3.5	35°F	53°F
4.0	31°F	46°F
5.0	28°F	37°F
6.0	-	31°F
6.5	-	28°F

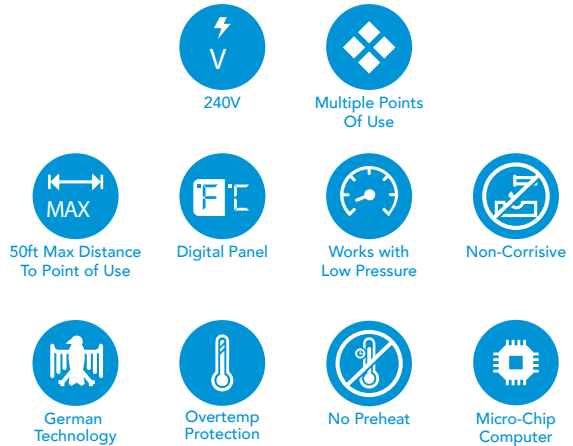

*Gallons per minute indicated on the Temperature Increase table are calculated assuming an outlet temperature of 105°F. Variable factors such as alternate incoming water temperature or incorrect installation may yield different results.



PRODUCT INNER STRUCTURE

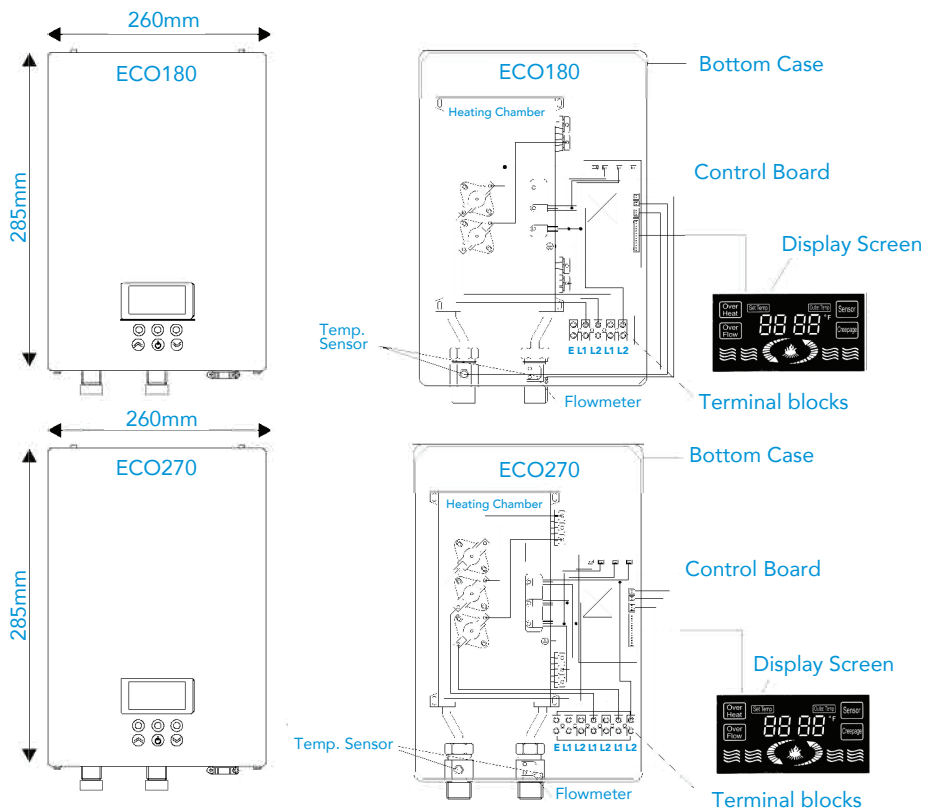

Fig. 05

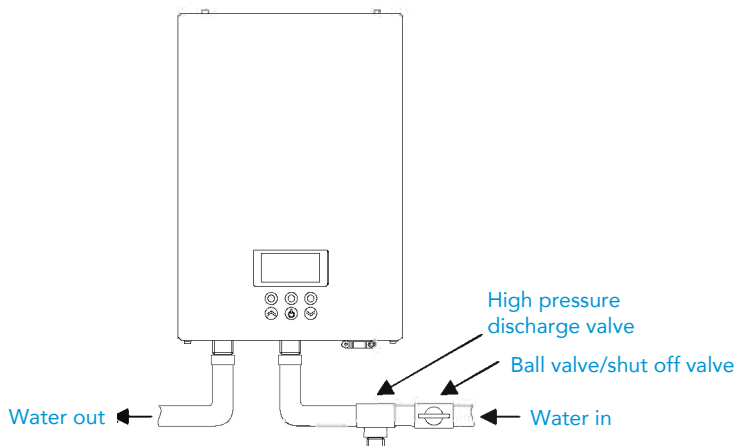

Fig. 06



INSTALLATION GUIDELINES

NOTE: Installation must be in compliance with the National Electrical Code and your local electrical and plumbing codes.

1. Do not install the unit in a room where there is a chance of freezing.
2. DO NOT install this water heater near tinder, volatile or flammable substances, or near a strong magnetic field. The unit must only be mounted in a VERTICAL position near the water fittings.
3. Mount the unit to a flat section of wall, well away from any potential water splashes or spray. Be sure to use wall anchors, or screw directly into studs.
4. Position the unit upright with all plumbing connections at the bottom of the unit.
5. Make sure the water heater and all fittings are complete and intact.
6. Make sure that the main power supply, water pressure, ground, amperage, voltage, and wiring meet all standards.
7. The water heater must be connected to a properly-grounded, dedicated branch circuit with the proper voltage rating. The ground must be connected to the "ground bar" at the circuit breaker panel.
8. This water heater MUST be permanently connected to fixed and dedicated circuit breakers.
If the heater will be unused, switch off the circuit breakers.

INSTALLATION

Locate an appropriate place on a section of wall that meets all safety and installation requirements.

Front and back of the appliance (please see Fig. 07).

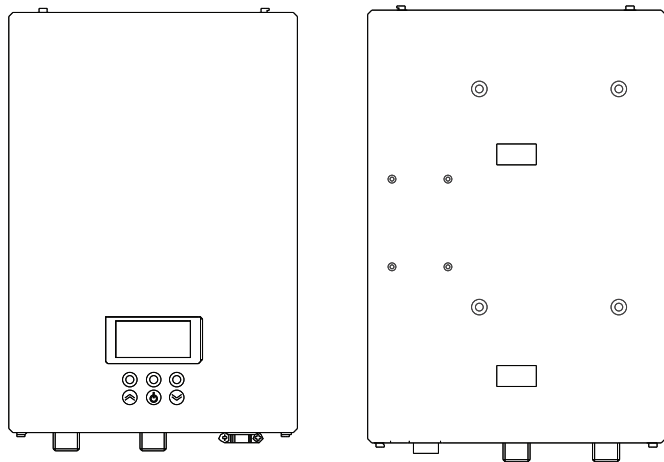

Fig. 07

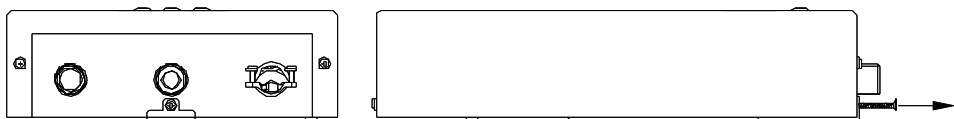

Fig. 08

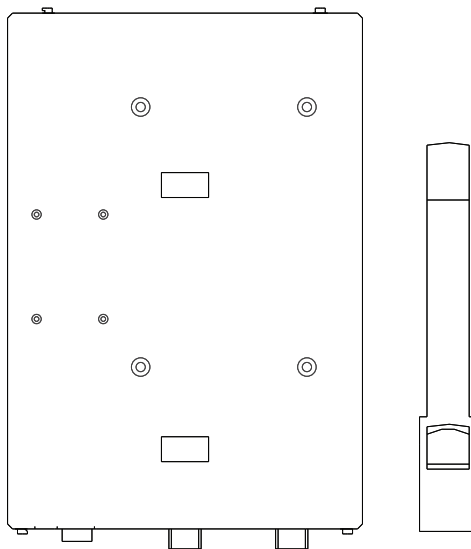

Fig. 09

Hold the back bracket hanger in position against the wall in the desired hanging location. Check to make sure that the bracket is level. Mark the wall where the mounting holes should be located. Drill holes of ¼" diameter in the marked locations. If you are on a stud, screw the bracket directly into the wall. If you are not on a stud, insert the plastic anchor in the hole, and secure the bracket using the screws supplied (Fig.10).

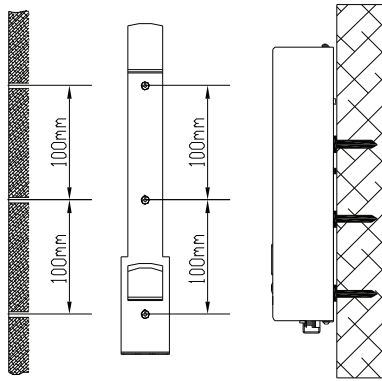

Fig. 10

Remove (4) screws and washers (Fig 11) from the unit to free the front cover. Carefully lift the front cover off the unit a few inches. Disengage the ribbon cable connecting the front cover LCD panel to the main control board or the unit (Fig 12). Remove the cover completely.

Please note: If LCD connection cable cannot be disengaged, simply set the front cover aside and keep the cable connected.

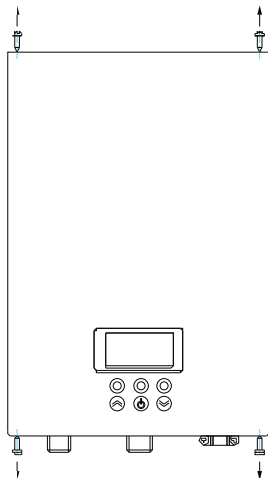

Fig. 11

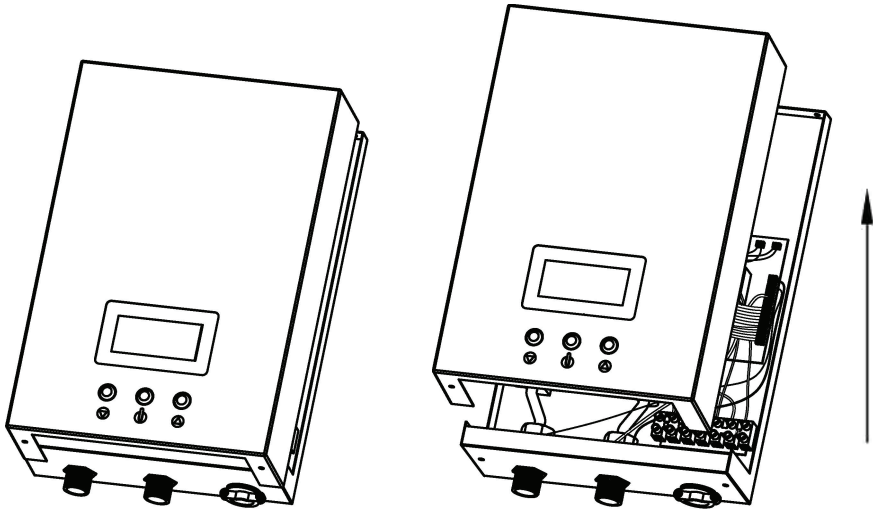

Fig.12

Attach unit to mounting bracket by sliding onto tabs. Make sure the unit is properly secured to both tabs of the bracket. Install bottom, center screw to affix the unit to the bracket to complete mounting.

Important notes about water connections:

1. All water pipe must comply with national and applicable state and local water pipe codes.
2. The unit should be connected directly to the main water supply. Flush pipe with water to remove any debris or loose particles.
3. All connections to the unit should be $\frac{3}{4}$ " NPT. Larger pipe can be connected but the appropriate adapters must be used.
4. Please remember to install rubber seal rings at the connections. When all water connections are completed, check for leaks and take corrective action before proceeding.

Connect the cold water supply to the threaded pipe labeled "inlet" and the hot water to the threaded pipe labeled "outlet". IMPORTANT: RUBBER WASHER MUST BE USED FOR PROPER SEAL.

Please use a backup wrench when installing water fittings. Connections are 3/4" NPT (Fig. 13).

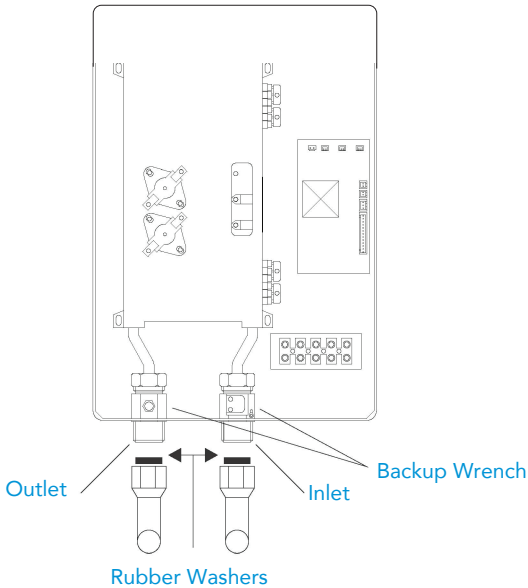

Fig.13

Important notes about electrical connections:

1. Before beginning any work on the electrical installation, be sure that the main breaker panel switch is OFF to avoid any danger of electric shock. All mounting and plumbing **MUST BE** completed before proceeding with the electrical installation.
2. All electrical work must comply with national and applicable state and local electrical codes.
3. All units must be connected to a properly grounded, dedicated branch circuit of proper voltage rating.
4. ECO180: Requires two dedicated double pole circuit breakers (2x50amp). Use two insulated supply cables per double pole breaker and a ground wire to connect to "ground bar". ECO270: Require three dedicated double pole circuit breakers (3x50amp for ECO270). Use two insulated wires for each of the three separate double-pole breakers and a ground wire connected to the "ground bar".

5. When connecting the wires to the terminal blocks, make sure the metal wire ends and the terminal blocks completely touch. Then, tighten the screws securely. Failure to properly tighten can result in an electrical short and burning of the terminal blocks.

Connect the power at the lower right side of the unit to the terminal block. Each pair of L1 and L2 should have its own corresponding double polled breaker. Note that the ECO 180 unit will be connected to two double pole circuit breakers while the ECO270 unit will be connected to three double pole circuit breakers (Fig.14).

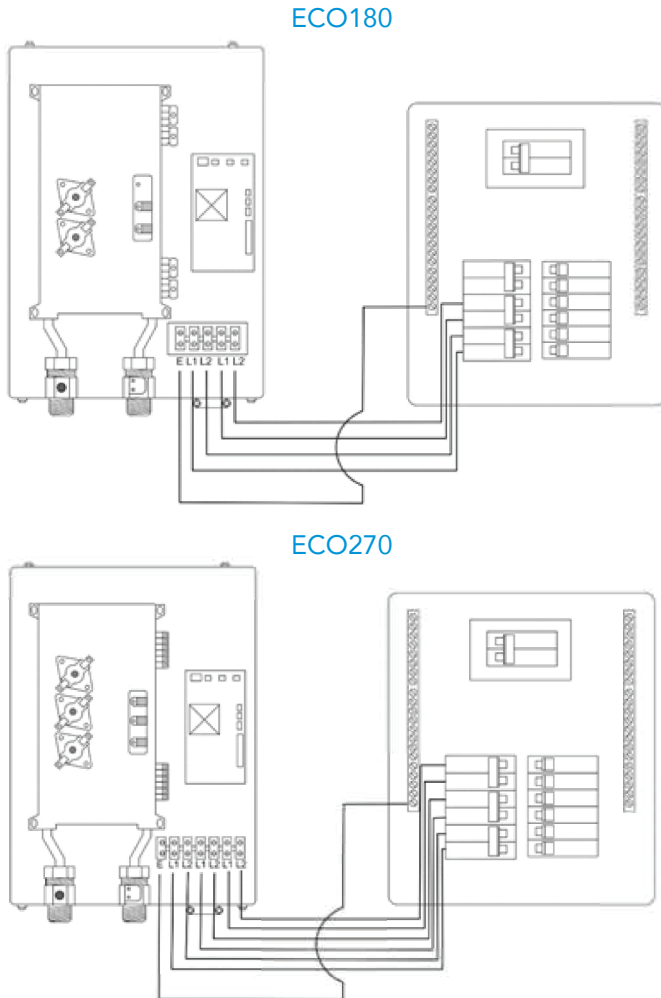

Fig.14

Reattach the ribbon cable for the LCD panel if disconnected and reinstall the front cover using the screws and washers previously removed. (Fig.15).

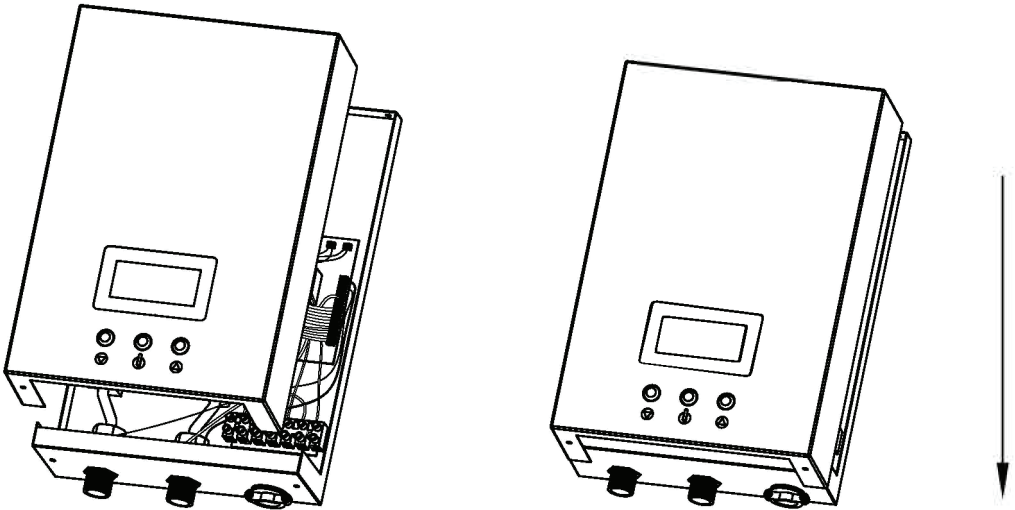

Fig. 15

How the unit works

1. This unit heats water instantaneously as it flows across the heating elements.
2. The electronic control monitors the flow rate and the incoming water temperature and then switches on the required number of heating elements to reach the set temperature.
3. The outlet water temperature will be higher than the setting if the minimum flow rate isn't met. The outlet water temperature will be lower than the setting if the maximum flow rate is exceeded.

Using the water heater-operation instructions

1. Turn on the water and allow it to run through the unit for a few minutes, until water flow is continuous and all air is purged from the water pipes. Check for and correct any leaking connections.

2. Turn on the circuit breakers to provide power to the unit.

3. Press the center button to turn on the heater. NOTE it will not start heating until water is provided to the unit.

If there is power to the unit, but no digital display, turn off the circuit breaker. Double check to make sure that the cable to the LCD panel on the front cover is correctly connected inside the unit, then turn the breaker back on.

4. After the unit is supplied with power, a beep sound can be heard and the display flashes the set temperature, then goes solid showing the actual output temperature for 30 seconds until the screen goes blank. the unit is now in standby mode.

5. Press the power button to activate/deactivate the unit. When the unit is ON, the LED display shows the actual water temperature of the outlet water.

6. The outlet water temperature can be adjusted by changing the temperature settings on the heater. Press ▲ and ▼ to adjust the temperature. The range of options for the temperature setting is 30°C-52°C/86° F-125° F.

WARNING: If the unit has been used recently, you may initially get a short burst of very hot water from the unit. Allow a few seconds for the water to cool down to the set point. Test the water before you take a shower. If the unit will not be used during winter, drain out any water completely so that the heater will not freeze.

Periodically clean the inlet filter screen and the shower head to maintain strong water flow.

7. Press  then press ▲ to convert the temperature display between Fahrenheit and Celsius.

8. The unit features an automatic memory function to avoid repetitive operation. When you turn on the water heater, the default set point will be the same as the last setting used.



TROUBLE-SHOOTING / DIAGNOSTIC CHART

PROBLEMS	POSSIBLE CAUSES	CORRECTIVE ACTIONS
1. Inlet and outlet fittings leaking	A. Fittings not tight B. Rubber washer worn-out	A. Tighten fittings. B. Change rubber washer.
2. Blank screen	A. Power not connected. B. LCD damaged. C. LCD not connected to PCB.	A. Connect power to the unit. B. Change LCD. C. Connect LCD to the PCB Board.
3. Functional keys not working	A. No water output. B. Water flow is too low. C. Key or PCB damaged.	A. Check water supply valves. B. Open valve to increase flow. C. Change key or PCB.
4. Water too hot	A. Temperature setpoint too high. B. Water flow is too low.	A. Set a lower temperature. B. Open valve to increase water flow.
5. Water too cold	A. Low temperature set. B. Too much waer flow.	A. Set a higher temperature. B. Reduce water flow.
6. Outlet flow noticeably decreases	Inlet strainer or shower clogged.	Clean strainer and shower.
7. LED displays E1	Outlet temperature is over 67°C/ 153° F.	A. Reduce the temperature. B. Turn up the water flow.
8. LED displays E3	Temperature sensor failure.	Please contact with the local dealer.
9. LED displays E4	Dry Heating.	Shut off. Clean all outlets from any debris, dirt, any particle or scale inside the pipe.
10. Pressure relief valve releases water	A. Outlet blocked. B. Inlet pressure over 100psi or 0.7Mpa.	A. Clean shower set. B. Reduce water pressure.
11. Display overflow	Inlet water flow is too high.	Reduce the inlet water flow.

WARNING: Corrections to problems 8, 9 and 10 should only be performed by qualified electrician or plumber. The person who initially installed the unit is the best one to contact for help, or contact Marey for service.

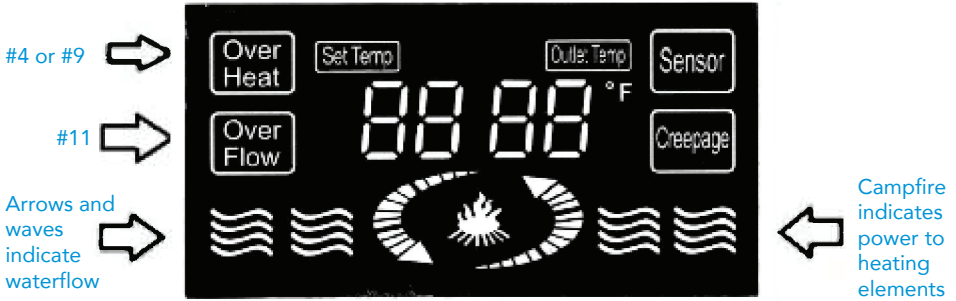

Fig. 16

NORMAL MAINTENANCE

Note: Do not attempt to repair this water heater yourself. Please call a service person for assistance. Always be sure to turn off all the breakers connected to your unit before servicing.

To ensure consistent water flow, the following is recommended:

1. Periodically remove build-up and dirt that may accumulate at the aerator of the faucet or in the shower head.
2. Periodically clean the built-in filter screen in the inlet connection of your water heater. Water supply must be turned off before cleaning the screen.

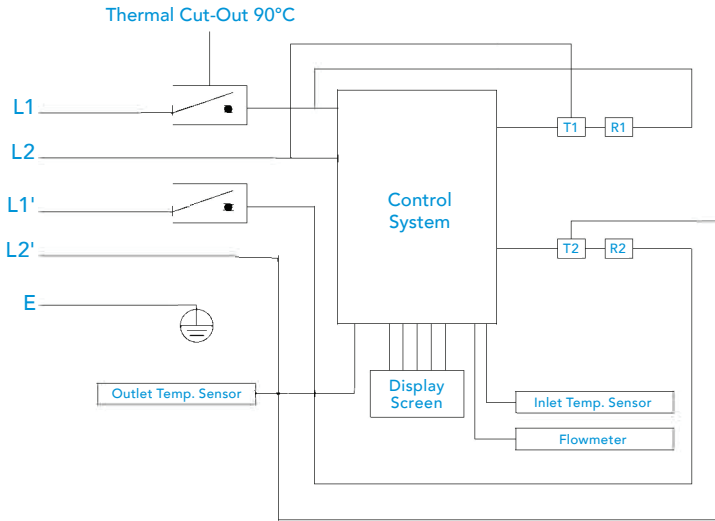

Fig. 17

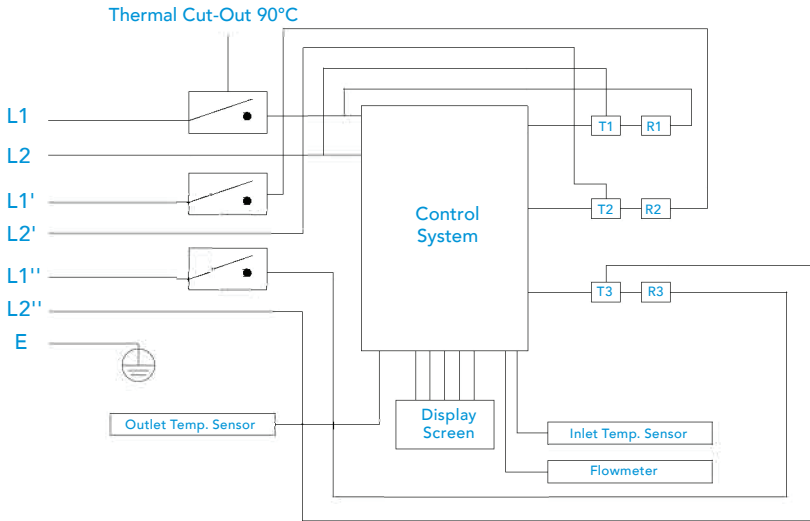
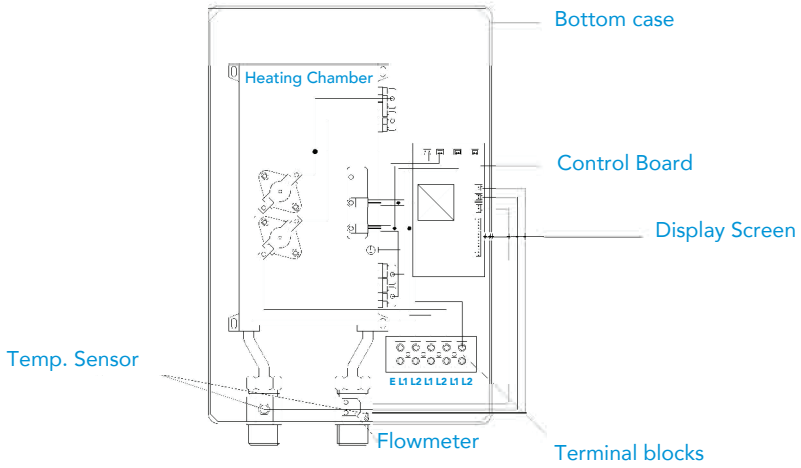

Fig. 18

REMARK: L: LINE R: HEATING SYSTEM T: TRIAC

ECO180



ECO270

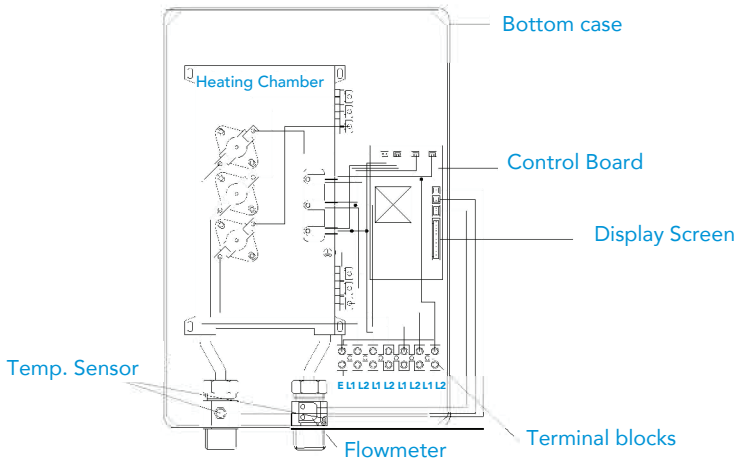

Fig. 19

Please feel free to contact us if you have any questions about our products, warranty service, or if you need assistance installing a unit.

We also strive for continuous improvement, so we welcome your comments, feedback and suggestions.



U.S.A

+1 (855) 627-3955

PUERTO RICO

(787) 727-0277

customerservice@marey.com

www.marey.com

