

# EC DECLARATION OF CONFORMITY

## OPERATING INSTRUCTION FOR PORTABLE BAG CLOSER

The undersigned, \_\_\_\_\_, representing YAO HAN INDUSTRIAL CO., LTD, NO 31, Lane 145, Fu Ying Rd., Shin-Chuang City, Taipei Hsien, Taiwan R.O.C., manufacturer, declares that the machine described hereafter:

Portable Bag Closer,

Model: \_\_\_\_\_

Provided that it is used and maintained in accordance with the generally accepted codes of good practice and the recommendations of the instructions manual, meets the essential safety and health requirements of the EC Machinery Directive.

For the most specific risks of this machine, safety and compliance with the essential requirements of the Directive has been based on elements of:

- the European Standard EN 202-1 & -2 - 1993 - Safety of machinery, based on the general principles for design.

<b>Model :</b>	Date: _____
<b>Serial No :</b>	
<b>Company :</b>	
<b>Address :</b>	
<b>Year of Construction :</b>	Signature: _____
(Please write down Serial No. from machine)	

- Read the instruction before operating this machine.
- EC declaration of conformity is included in this manual.
- Always keep this instruction.

## Contents :

1. General safety rules.
2. Technical data.
3. Emission of machine.
4. Unpacking of machine.
5. Defined application.
6. Explanation of symbols used on machine.
7. Residual risk.
8. Before operation.
9. Connection & disconnection of power.
10. Operation.
11. Adjustments.
12. Replacing Parts.
13. Maintenance and Lubrication.
14. Lubricator.
15. Ordering Parts.

### 1. General Safety Rules.

**Warning !** When using electric tools, basic safety precautions should always be followed to reduce the risk of fire, electric shock and personal injury, including the following.

Read all these instructions before operating this product and save these instructions.

1. Keep work area clean.
  - Cluttered areas and benches invite injuries.
2. Consider work area environment.
  - Do not expose machine to rain. Do not use machine in damp or wet locations. Keep work area well lit. Do not use machine where there is risk to cause fire or explosion.
3. Guard against electric shock.
  - Avoid body contact with earthed or grounded surfaces.
4. Keep children away.
  - Do not let visitors touch machine or extension code. All visitor should be kept away from work area.
5. Store idle tools.
  - When not in use, tools should be stored in a dry, high or locked up place, out of reach of children.
6. Use the right needle.
  - Do not force small needles or attachments to do the job of a heavy duty. Do not use needles for purposes not intended.
7. Dress properly.
  - Do not wear loose clothing or jewellery, they can be caught in moving parts.

Wear protecting hair covering to contain long hair.

8. Do not abuse the cord.
  - Never carry the machine by cord or yank it to disconnect it from the socket. keep the cord away from heat, oil and sharp edges.
9. Do not overreach.
  - Keep proper footing and balance at all times.
10. Maintain machine with care.
  - Follow instructions for lubrication and changing accessories. Inspect power cord and/or extension cord periodically and if damaged have it repaired by an authorized serviced facility. Keep handle dry, clean and free from oil and grease.
11. Disconnect tools.
  - When not in use, before servicing and when changing accessories.
12. Remove adjusting keys and wrenches.
  - Form the habit of checking to see that keys and adjusting wrenches are removed from the machine before turning it on.
13. Avoid unintentional starting.
  - Do not carry a plugged-in machine with a finger on the switch. Ensure switch is off when plugging in.
14. Use outdoor extension leads.
  - When machine is used outdoors, use only extension cords intended for outdoor use.
15. Stay alert.
  - Watch what you are doing. Use common sense. Do not operate machine when you are tired.
16. Check damaged parts.
  - Before further use of the tool, a guard or other part that is damaged should be carefully checked to determine that it will operate properly and perform its intended function. Check for alignment of moving parts, free running of moving parts, breakage of parts, mounting and any other conditions that may affect its operation.
17. Warning.
  - The use of any accessory or attachment, other than those recommended in this instruction manual, may present a risk of personal injury.
18. Have your machine repaired by a qualified person.
  - This machine is in accordance with the relevant safety requirements. Repairs should only be carried out by qualified persons using original spare parts, otherwise this may result in considerable danger to the user.

**Particular safety instruction for this bag closer.**

1. This bag closer is designed for the operation of right handed use only.
2. Do not continuously operate this bag closer for more than 30 mins without any rest and/or any support of machine.
3. Be sure to wear hearing protection during operation.

## 2. Technical Data.

Natures	Value	
	N-600A	N-602A
Model	N-600A	N-602A
Speed	250~300 bags/H	250~300 bags/H
No. of needle	Single needle	Double needles
Needle specification	DN x1, #25	DN x1, #25
Net Weight	6 kgs	6.3 kgs
Noise level	80 ~ 84 dB(A)	80 ~ 84 dB(A)
Vibration Level	20-25m/sec*2	20~25 m/sec*2
AC Motor	1Ø; 220/240V; 90W	1Ø; 220/240V; 90W
DC Motor	12V or 24V	12V or 24V

STANDARD ACCESSORIES		
Model	N-600A	N-602A
Needles	5 pcs	5 pcs.
Thread	2 rolls	2 roll.
Screw Driver	1 pce.	1 pce.
Needle Bar Spanner	1 pce.	1 pce.
Oil	1 can.	1 can.
Carbon brush	2 pcs.	2 pcs.

## 3. Emission of machine.

Noise Level :

measure in a distance of 1 m to machine surface (idle run)

noise level :  $L_{wa} = 78 \sim 81 \text{ dB(A)}$ .

emission level according to working station :

$$L_{pa} = 81 \sim 84 \text{ dB(A)}.$$

Vibration Level :

measure on the handle of machine : 20~25 m/sec\*2.

## 4. Unpacking of machine.

Check the following on receipt of machine

- packing of damage
- completeness of contents according to despatch note
- check the accessories when unpacking
- write down the serial number of machine on the cover page of instruction.
- notify the freight forwarder and the ealer of any damage immediately.

**8. Before Operation.**

**A) Needle Assembly / Disassembly : ( See also Fig.01 & Fig.02 )**

- a) Loosen the clamping nut ( 6001432 ) of needle bar ( 6001431 ) by using the special wrench.
- b) Turn gear ( 6001401 ) so as to raise the needle to its highest position, and take off the worn needle.
- c) Put the new needle into the bottom of needle bar as far as possible. Be sure to keep the needle scarf facing toward the looper cover (3001206) during the installation of new needle.
- d) Turn and tighten the clamping nut ( 6001432 ) of needle bar.

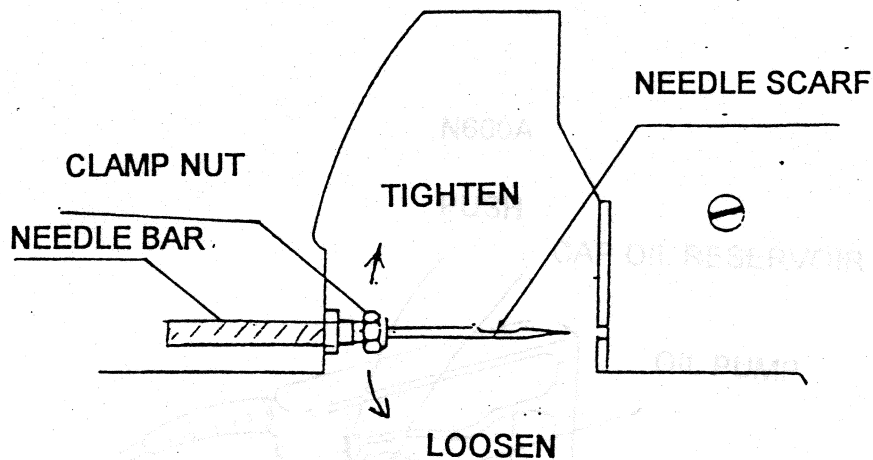

**Fig. 01**

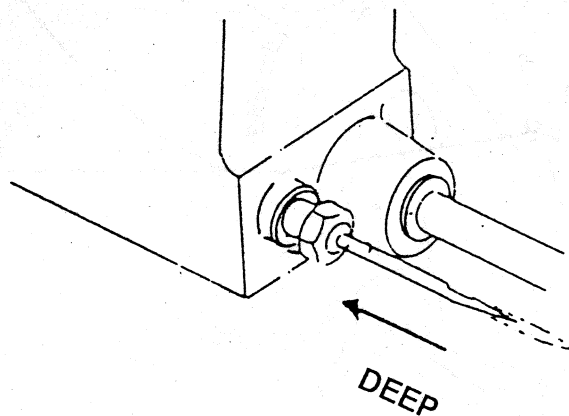

**Fig. 02**

**B) Threading : ( See also Fig. 03 & Fig. 03-1 )**

- a) Threading procedure for N600A/N: Please refer Fig. 033
- b) Threading procedure for N602A/N602H : Please refer Fig. 03-1.
- c) While thread is tensioned too much, the thread is easy to break and the sewing surface is easy to wrinkle. While thread is not tensioned enough, the thread is easy to break and continuity of sewing line is not easy to be kept. Therefore; it is better to keep a suitable tension for the thread during threading.
- d) Be sure to inspect the spring of thread passing ( 6001014 ). If worn, be sure to change it before threading. In order to get a suitable tension of thread, please adjust the screw (6001016) of thread passing , and the nut of manual adjuster ( 6001015 ).

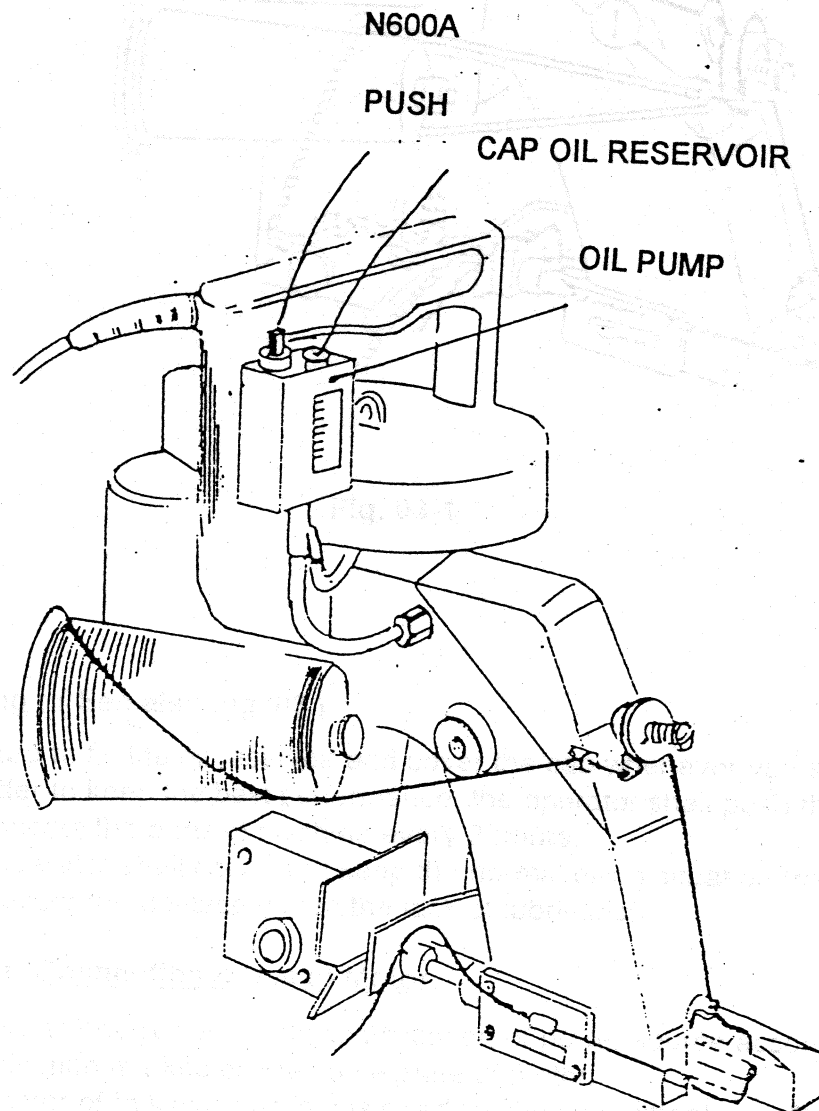

**Fig. 03**

10. Operation of Machine : ( See also Fig. 04 & Fig. 01 )

A) Machine Preparation :

- a) The operator shall check the oil reservoir and fill it with oil up to the level marked on the reservoir. The operator shall also check the parts of motor and needle bar.
- b) He shall push the oiling button ( 607206 ) with index finger when the machine is running and cover the trigger button ( 607207 ) with index finger when the trigger button is released.

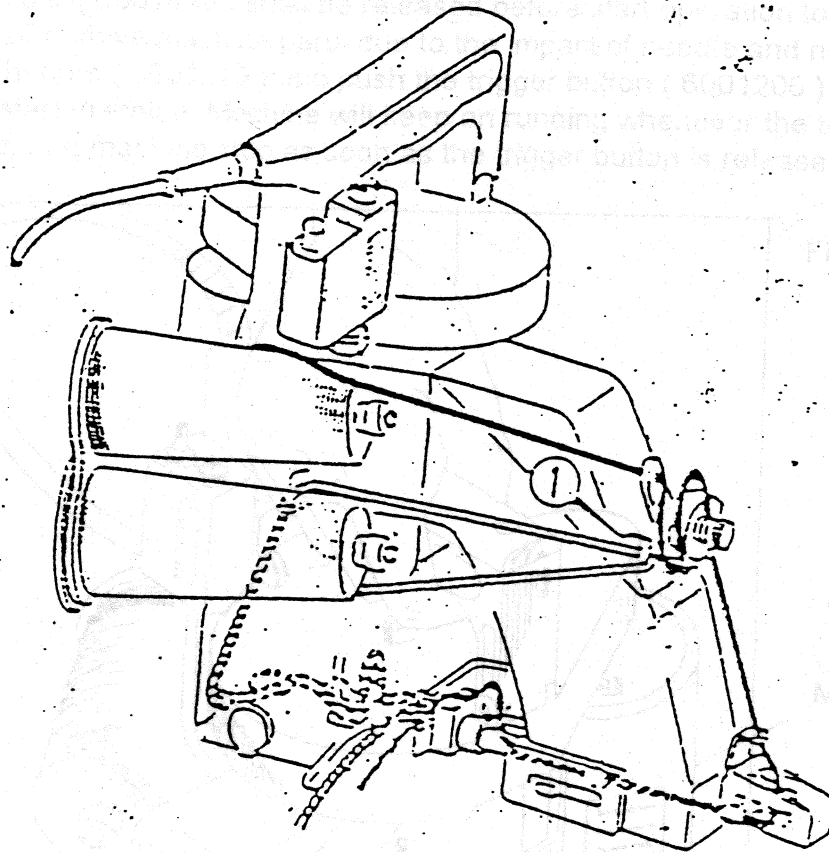

Fig. 03-1

C) Oiling : ( See also Fig. 03 )

- a) Be sure to fill the oil reservoir and cover the cap whenever you start your work.
- b) In order to keep the best performance, the operator shall push the oiling button to lubricate the parts of machine every 3 hours.
- c) The operator shall check and keep the normal oiling situation from time to time to prevent the damage due to the lack of lubrication.

9. Power Connection & Use of Motor.

- a) Be sure to check the correct specification of power source according to the specification marked on the name plate of motor.
- b) The motor of this machine is designed for the intermittent use. Do not continuously operate this machine for a long time. It will damage the performance of motor.
- c) Frequently inspect the brush of motor. If worn, change a new brush.

10. Operation of machine. ( See also Fig. 04 & Fig. 04-1 )

**A) Machine Operation**

- a) The raise bar ( 6001446 ) shall be released before start operation to prevent the damage of relative machine parts due to the impact of needle and needle bar.
- b) Hold the handle ( 6001229 ) and push the trigger button ( 6001206 ) with index finger to start machine. Machine will keep on running whenever the trigger button is pushed, and machine stop as soon as the trigger button is released.

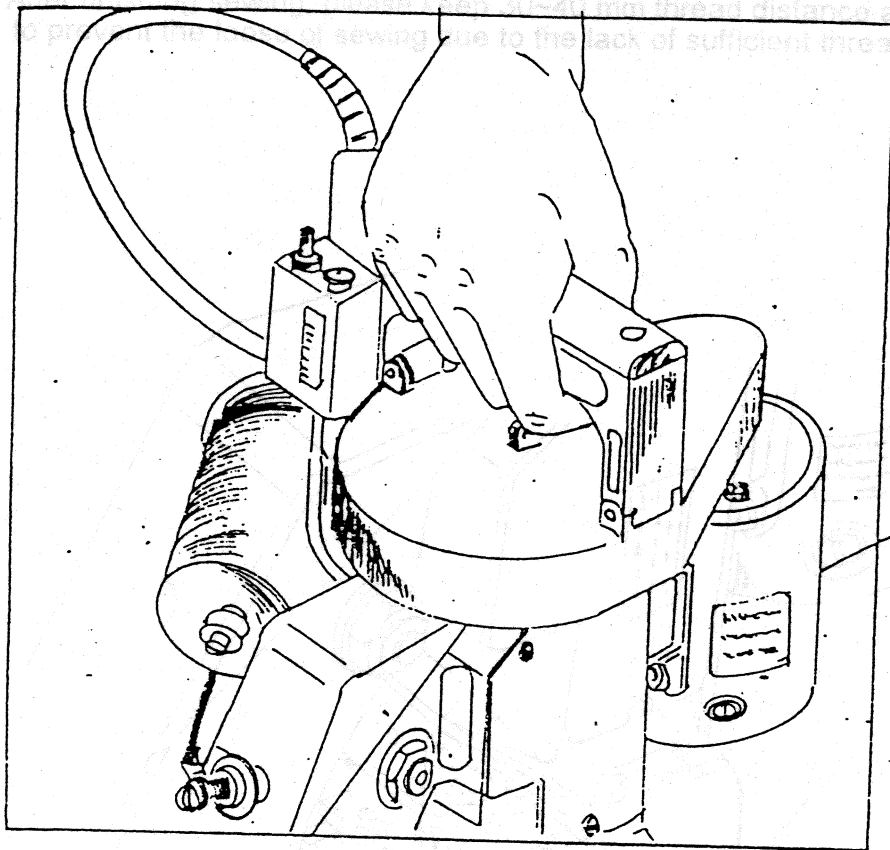

Fig. 04

MOTOR

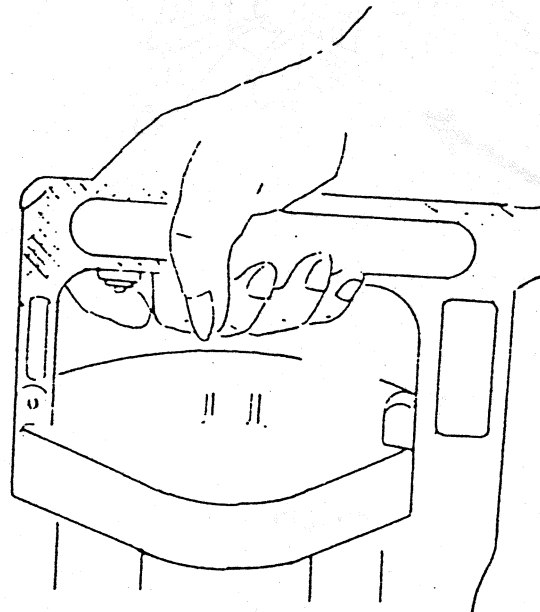
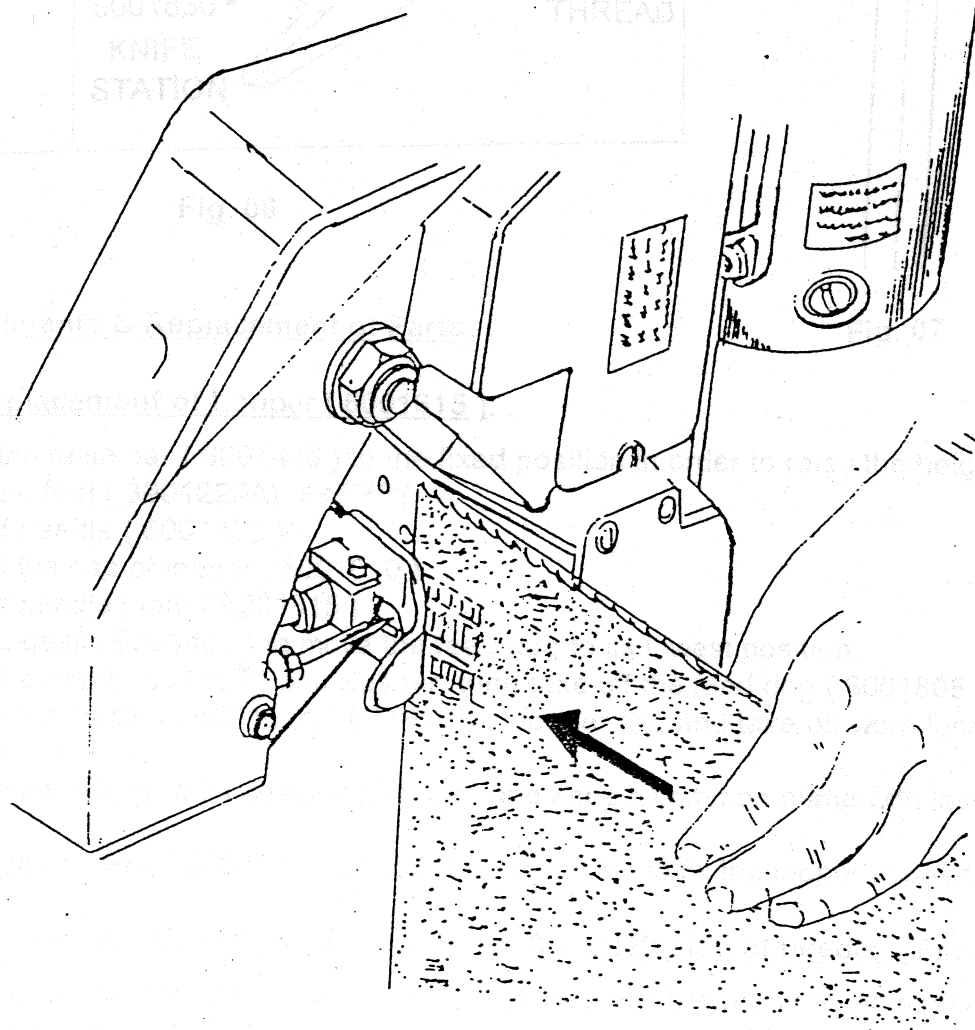

FIG-04-1



**B) Sewing Operation. ( See also Fig. 05 & Fig. 06 )**

- a) Straighten the parts of bag where is ready to be sewed before sewing.
- b) Take an appropriate sewing distance from the top end of bag according to the material of bag. In general the appropriate distance would be 100 mm for weaving bag, 50 mm for paper and PE/PP bag, and 110 mm for the sisal bag or the bag of similar material.
- c) Hold the bag and insert the bag into between the pressure foot ( 3001220A) and needle plate ( 3001208 ). During sewing, please just keep the sewing line straight and going forward. Do not pull the bag backward and upward or downward.
- d) After finishing sewing, please keep 30~40 mm thread distance and trim the thread to prevent the loose of sewing due to the lack of sufficient thread length.



**Fig. 05**

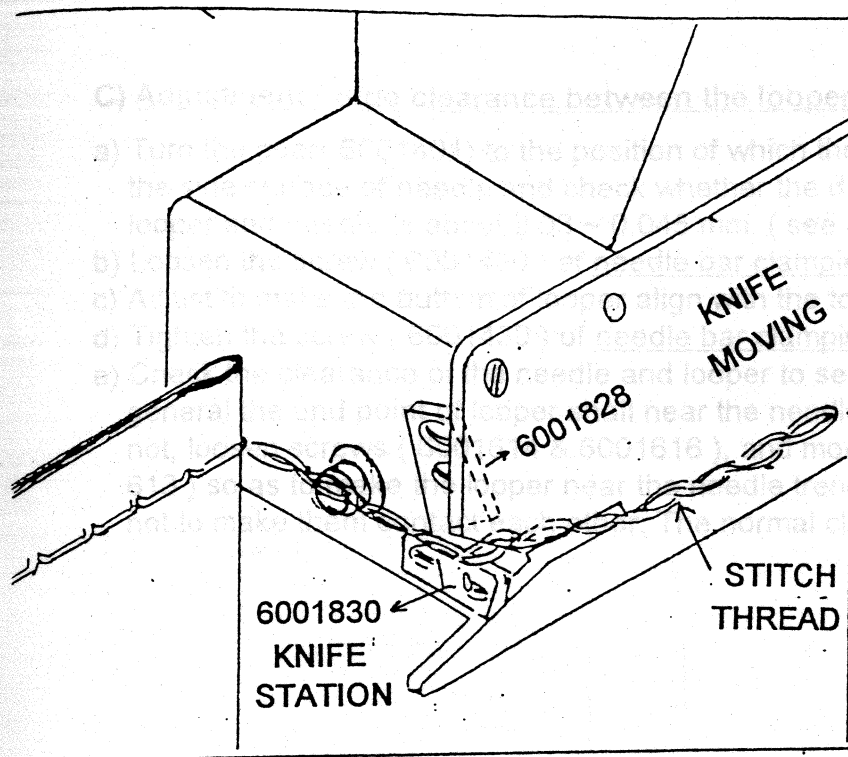

Fig. 06

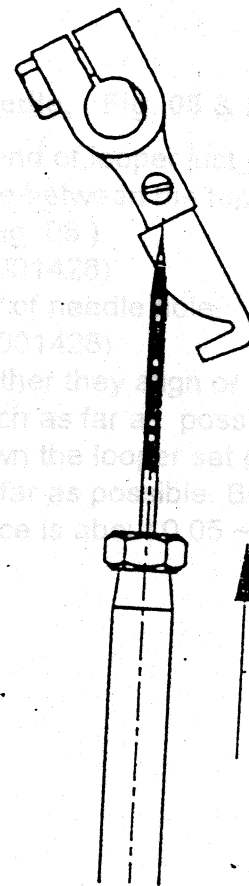

Fig. 07

## 11. Adjustments & Replacement of Parts.

### A). The replacement of Looper ( 6001615 ).

- a ) Raise the raise bar ( 6001446 ) to the fixed position in order to raise the height of pressure foot ( ~~3001220A~~ 6001441 )
- b) Take off needle ( 6001433 )
- c) Take off the cap of looper ( 6001020 )
- d) Take off needle plate ( 6001815 )
- e) Turn the gear ( 6001401 ) to move the feed dog to its lowest position.
- f) Take off screw ( 6001807 ) and washer, then take off the feed dog ( 6001808 ).
- g) Loosen the screws ( 6001614, 6001616 ) of looper set, and take off worn looper ( 6001615 ).
- h) Put the new looper to its deepest position, and keep a common plane with looper set.
- l) Tighten the screws ( 6001614 and 6001616 ) in order to fix the looper in position.

### B) Adjustment / distance between the looper & the left side of needle. ( Fig. 07 )

- a) Turn the gear ( 6001401 ) to check whether the distance between the left stroke limit of looper and needle is about 2.9 ~ 3.1 mm. ( see also Fig. 07 )
- b) If the distance is not correct, take off cover plate ( 6001020 ) and adjust the distance in the suitable range ( 2.9 ~ 3.1 mm ).

D) Adjustment / Sewing distance. ( Fig. 10 )

**C) Adjustment / Side clearance between the looper & needle. ( Fig. 08 & Fig 09 )**

- a) Turn the gear ( 6001401 ) to the position of which the top end of looper just exceed the side surface of needle and check whether the distance between the top end of looper and needle is about 0.03 ~ 0.045 mm. ( see also Fig. 08 )
- b) Loosen the screw ( 6001430 ) of needle bar clamping ( 6001428 )
- c) Adjust to make the bottom of looper align with the top end of needle hole.
- d) Tighten the screw ( 6001430 ) of needle bar clamping ( 6001428 )
- e) Check the clearance of the needle and looper to see whether they align or not. In general the end point of looper shall near the needle trench as far as possible. If not, loosen screws ( 6001614 & 6001616 ), and move down the looper set ( 6001613 ) so as to make the looper near the needle trench as far as possible. Be sure not to make them contact each other. The normal clearance is about 0.05 ~ 0.15 mm.

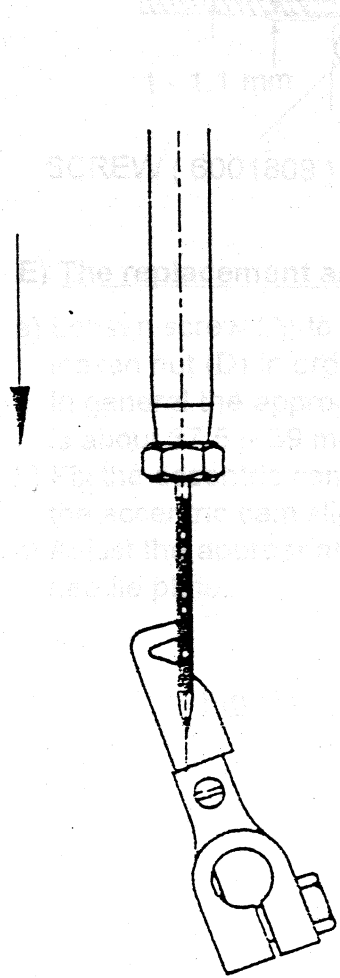

Fig. 08

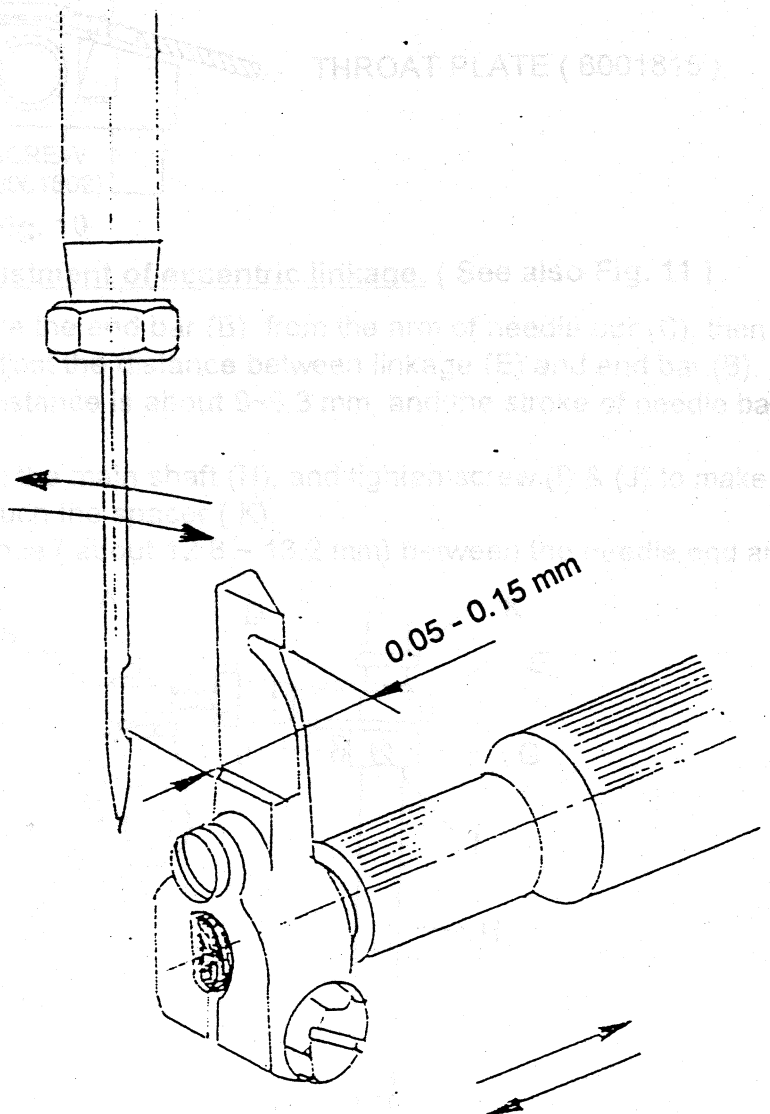
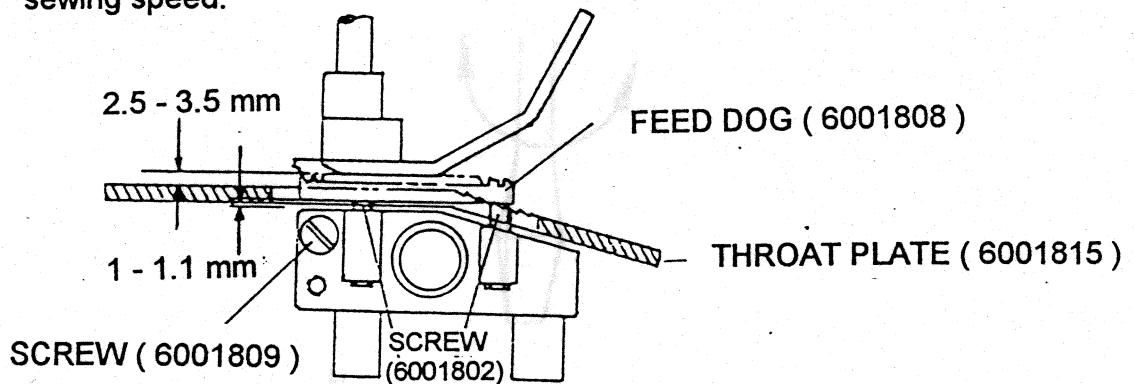

Fig. 09

**D) Adjustment / Sewing distance. ( Fig. 10)**

- a) The suitable distance has been set before packing. In general the appropriate sewing distance is 7.25 ~ 7.6 mm. If the distance is too long, please check as the followings :
- b) Whether the feed dog is worn or not ? If worn, please change it.
- c) While the sewing distance is normal, the top end of feed dog ( 6001808 ) be 2.5 ~ 3.5 mm higher than the needle plate ( 6601815 ). If the height of new feed dog is not in the normal range, please adjust the screws ( 6001802 & 6001802-1 ) on the feed dog set. It would be better to adjust the feed dog to the highest normal level. The higher the feed dog, the larger the sewing distance, and the higher the sewing speed.



**Fig. 10**

**E) The replacement and adjustment of eccentric linkage. ( See also Fig. 11 )**

- a) Loosen screw (A) to separate the end bar (B) from the arm of needle bar (C), then loosen nut (D) in order to adjust the distance between linkage (E) and end bar (B). In general the appropriate distance is about 9~9.3 mm, and the stroke of needle bar is about 37.5 ~ 39 mm.
- b) Fix the eccentric cam (G) on the main shaft (H), and tighten screw (I) & (J) to make the eccentric cam slightly touch the spacer ( K).
- c) Adjust the appropriate distance ( about 12.8 ~ 13.2 mm) between the needle end and needle plate.

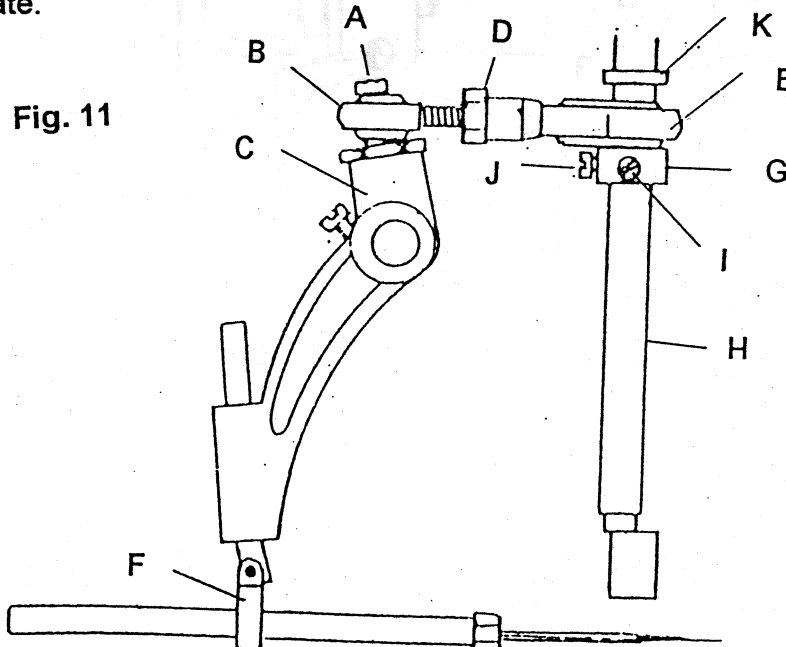

**Fig. 11**

**F) Replacement and adjustment / Cam & Mechanism of looper. ( See Fig. 12 )**

- a) Loosen screws ( B ) & ( B' ), and adjust the crank of looper ( D ) so as to make the transmission between Cam ( C ) & crank ( F ) smooth, then tighten screw ( H ).
- b) The distance between cam ( C ) and crank ( E ) could be adjusted through the adjustment of spring pressure. Loosen screw ( I ) and loosen or tighten the spring supporter ( H ) with screw driver to adjust an appropriate pressure of spring ( G ). After adjustment fix the screw ( I ) again.

**A) Thread break & Jump Needle**

- a) The thread shall be lubricated during sewing while the material of bag is that of bitumen or water proofed material.
- b) Check whether the threading is correct, the part of thread passing is worn out, and the thread tension is suitable.
- c) Check whether the gap between needle and looper is correct. If looper is worn out, replace a new one.

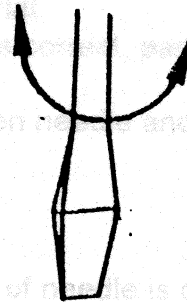

**B) Needle break**

- a) Check whether the installation of needle is correct, and needle trench is facing forward.
- b) Check whether the distance of looper is normal.

**C) Threading does not tie, or the resistance is not uniform.**

- a) Check whether the needle and looper are worn out or distorted. If yes, replace it.
- b) Check whether the thread tension is suitable. If not, adjust it.
- c) Check whether the feed is changed.

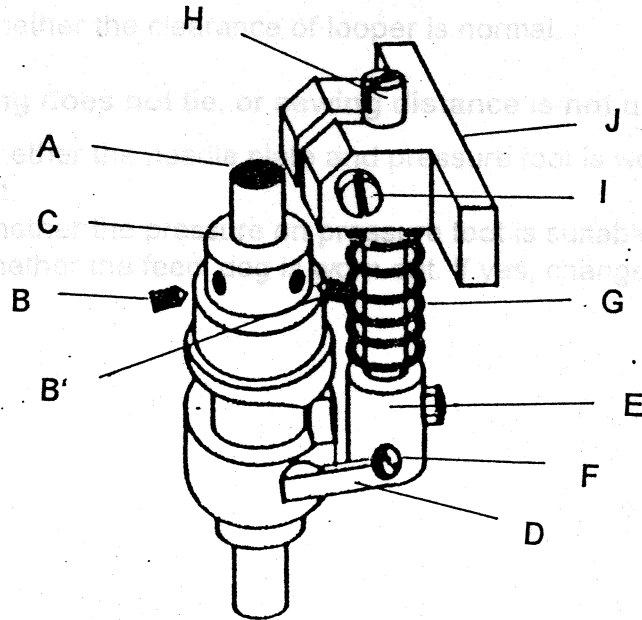

**Fig. 12**

## **12. Cleaning.**

- a) Immerse machine into the oil with level 110 ~ 130 mm height for 20 ~ 30 sec. Be sure that the oil used could be the specified oil as shown in the following table.
- b) Do not immerse the motor and electric cable into the oil.
- c) Clean the dust on the machine frame and any internal parts with brush.

## **13. Trouble Shooting.**

### **A) Thread break & Jump Needle.**

- a) the thread shall be lubricated during sewing while the material of bag is that of bitumen or water proved material.
- b) Check whether the threading is correct, parts of thread passing is worn out , and the thread tension is suitable.
- c) Check whether the gap between needle and looper is correct. If looper is worn out replace a new one.

### **B) Needle break.**

- a) Check whether the installation of needle is correct, and needle trench is faced leftward.
- b) Check whether the clearance of looper is normal.

### **C) Threading does not tie, or sewing distance is not uniform.**

- a) Check whether the needle plate and pressure foot is worn out or distorted. If yes, replace it.
- b) Check whether the pressure on pressure foot is suitable. If not, adjust it.
- c) Check whether the feed dog is worn out. If yes, change it.

**EC DECLARATION OF CONFORMITY**

Additional Instruction for the replacement of feed dog.

- 1. Remove the feed dog as the following steps:
  - a. Turn the machine pulley until the feed dog is at its lowest position.
  - b. Remove the screw and the washer.
  - c. Pull the feed dog gently out off the carriage block.
- 2. Install new feed dog as the following steps:
  - a. Put the new feed dog to the carriage block.
  - b. Fix the screw and washer.

Portable Bag Closer

Model:

Additional Instruction for the replacement of motor brush.

- 1. Remove the worn brush as the following steps:
  - a. Loosen the screw at left side of motor.
  - b. Remove the brush set from its position shown as the following Fig.
- 2. Install brush set as the following steps:
  - a. Put the new brush set into its position.
  - b. Fix the screw.

European Standard EN 12443:2002 - Safety of machinery - basic concepts and general principles for design

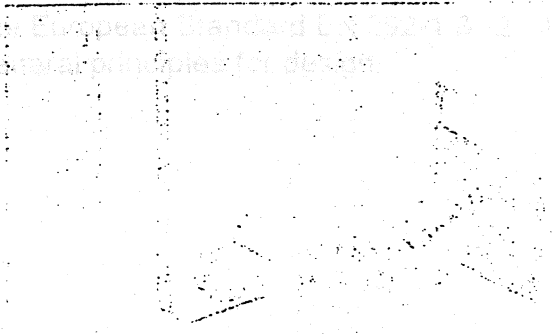

This \_\_\_\_\_  
\_\_\_\_\_  
\_\_\_\_\_  
\_\_\_\_\_ Managing Director