

	Legend  Meg-Ohm Meter  Shielded Wires  Customer Provided Wiring	Drawn By: KM Delamater Checked: R. Zelm	CableGuard GP500-CG-AS Typical Wiring Diagram	Date: 10/24/2019
				Scale: None

Tech Support: 800-778-5689



3/16" (4x)

Hook-up to Power Supply

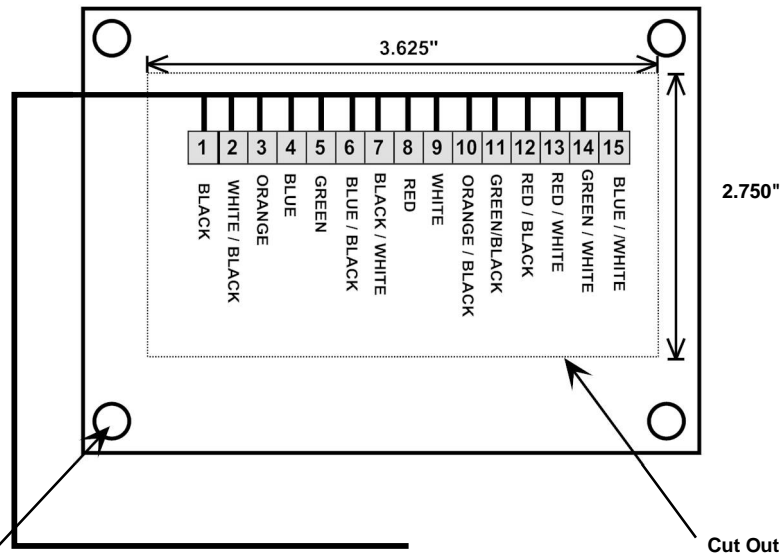
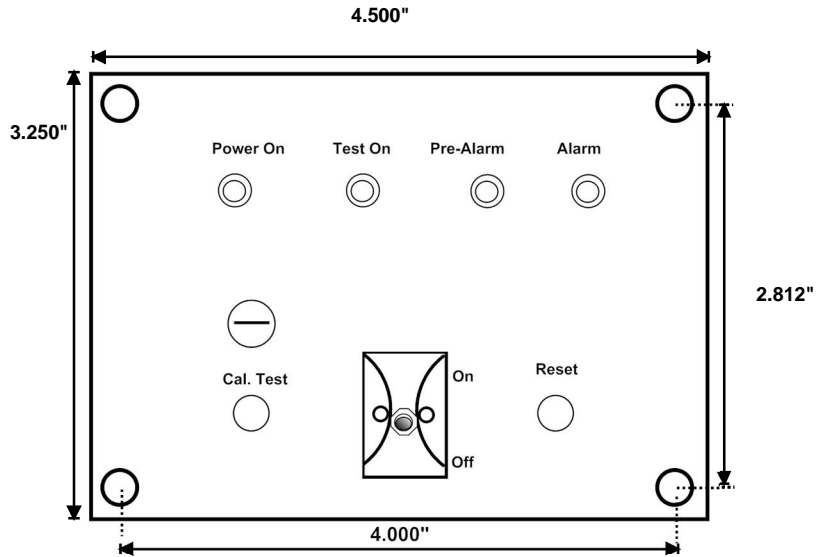
Column Wire #	Color Code
TB11	Blue
TB12	White/Black
TB13	Orange
TB14	Black
TB20	Blue w/Black Stripe
TB21	Black w/White Stripe
TB22	Red w/ Black Stripe
TB23	Green w/ Black Stripe
TB24	Orange w/ Black Stripe
TB25	Blue w/White Stripe
TB26	Red w/ White Stripe
TB27	Green w/ White Stripe
TB28	Green
TB29	White
TB30	Red



CableGuard Installation Instructions Model: GP500-CG-AS

Input power 120 +/- 10% VAC 50/60 Hz @ .5A Max.

Test Voltage 500 VDC @ 200uA Max.

Unit to be installed in a "clean" and "dry" environment, in a switchgear or a NEMA type enclosure.

Ambient Temp. -20° F to 140° F

Maximum relative humidity 80% for temperatures up to 31° C decreasing linearly to 50% relative humidity at 40°

Pollution degree 2 Altitude up to 2000m

Wiring: 16 AWG, 600V switchboard wire

MEASUREMENT CATEGORY III

NOTE: If unit is installed in an enclosure, please skip to # 4.

1. The device is a Class 1 according to IEC 61010-1 for electric safety and chassis must be grounded to the main protective earth in the end application.
2. Position din rail inside Cable starter housing for clearance and ease of wire installation. Drill four (2) holes for #10 screws and install rail(s). Snap CableGuard onto rail. If back pan mounting is desired drill two holes for #10 screws and mount CableGuard using holes provided in the enclosure.
3. Mount the meter according to drawings supplied.
4. To install the remote LED/Switch assembly, drill four (4) $\frac{1}{8}$ " holes and cut out a $2 \frac{3}{4}$ " x $3 \frac{5}{8}$ " clearance hole for the assembly. Mount the assembly using the mounting holes provided in the panel (panel is normally located near the meter indicator). If using the optional EZ bracket (part number 8013-EZBK) drill (4) $\frac{3}{16}$ " holes to mount the bracket and (1) $\frac{1}{2}$ " clearance hole for the cable.
5. Install warning stickers (provided with the CableGuard) on terminal boxes of equipment to be tested.

All wiring should be 16/18 AWG. Torque requirements 1.3 NM or 1.0 FT-/LBF.

6. Connect terminals (1) and (2) to input power source (see wiring diagram & nameplate).
7. For offline testing ONLY connect terminals (3) and (4) to control sensing transformer (see wiring diagram).

NOTE: For online and offline testing leave terminals open.

8. Connect terminals (5), (6), and (7) to an alarm panel or PLC inputs, if required.
9. Connect terminals (8), (9), and (10) to an alarm panel or to the main breaker shunt strip, if so desired.
10. Connect terminals (11) through (14) to the remote LED/switch assembly. Terminal (11) is the yellow LED positive output; terminal (12) is the red flashing LED positive output; terminal (13) is the yellow flashing LED positive output; and terminal (14) is the LED common.



CableGuard Installation Instructions Model: GP500-CG-AS

Input power 120 +/- 10% VAC 50/60 Hz @ .5A Max.

Test Voltage 500 VDC @ 200uA Max.

Unit to be installed in a "clean" and "dry" environment, in a switchgear or a NEMA type enclosure.

Ambient Temp. -20° F to 140° F

Maximum relative humidity 80% for temperatures up to 31° C decreasing linearly to 50% relative humidity at 40°

Pollution degree 2 Altitude up to 2000m

Wiring: 16 AWG, 600V switchboard wire

MEASUREMENT CATEGORY III

11. Connect the (ground) terminal (15) to the mechanical ground of the equipment being tested.
12. Connect the (test) terminal (16) to the B phase of the AC Buss. System. (See wiring diagram).
13. Connect (pre-alarm) terminals (17), (18), and (19) to an alarm panel or PLC, if desired.
14. Connect terminals (20) through (30) to the remote LED/Switch assembly, terminal (20) and (21) is the "reset" button. Terminal (22), (23) and (24) are the "Cal. /Test pushbutton. Terminal (25), (26) and (27) are the "Cal." Pot adjust. Terminal (28) is the green LED positive output. Terminal (29) and (30) are the "on/off" switch.
15. Connect terminals (31) and (32) to the meter. Observe correct polarity; terminal (31) is positive and terminal (32) is negative. *NOTE: When using 4-20mA transducer option, wire transducer input in series with mere connections (see wiring diagram).*
16. Proceed with operating instructions.



CableGuard Operating Instructions Model: GP500-CG-AS

Input power 120 +/- 10% VAC 50/60 Hz @ .5A Max.

Test Voltage 500 VDC @ 200uA Max.

Unit to be installed in a "clean" and "dry" environment, in a switchgear or a NEMA type enclosure.

Ambient Temp. -20° F to 140° F

Maximum relative humidity 80% for temperatures up to 31° C decreasing linearly to 50% relative humidity at 40°

Pollution degree 2 Altitude up to 2000m

Wiring: 16 AWG, 600V switchboard wire

MEASUREMENT CATEGORY III

1. After installation is completed on the unit, apply voltage to the CableGuard. Observe the green "Power On" and the yellow "Test On" LED are illuminated.
 - A. If using the CableGuard for offline testing only, energize the equipment being tested. Observe that the "TEST ON" yellow LED will turn off and the meter indicator will read all the way to infinity. If using for online and offline testing proceed to Step 2.
 - B. De-energize the equipment being tested. The yellow "TEST ON" LED should be illuminated, and the meter indicator will now read the value of the equipment's insulation condition.
2. Press the cal. /test button to check proper operation of the CableGuard and to see if the meter is calibrated correctly. Hold the cal. /test button for approximately 10 to 15 seconds. The meter indicator should first go to the "test" position carrot (1 Meg Ohm). Observe that the yellow flashing pre-alarm LED starts flashing approximately 5 to 10 seconds after pressing and holding the "CAL. TEST" button. (The pre-alarm contacts will change state when the yellow LED begins flashing and automatically reset when the yellow LED stops flashing). Then the CableGuard should trip on an alarm condition and the red "ALARM" LED should start flashing, while the yellow "TEST ON" LED should be off. The alarm and lockout contacts should now have changed state showing an alarm and preventing the equipment from operating if the lockout circuit is used.
3. Press the reset button. The CableGuard should return to a test condition. The red "ALARM" LED should stop flashing, while the yellow "TEST ON" LED should be illuminated. The meter indicator will now be showing the insulation value of the equipment being tested.
4. The system is now ready for normal operation.

EQUIPMENT MAINTENANCE

Only Qualified personnel shall perform maintenance of this device.

Before use all cables shall be checked for cracking or damage.

Only a 1.5A 250V AGC fuse shall be used with this device.

WARNING:

Before servicing any equipment being tested with a CableGuard system, one must turn off and lockout the CableGuard power and short the Cable windings to ground in order to remove any possible residual capacitive charge that may be present in the unit.



Technical Support: 800-778-5689

Models: GP500-MU-AS
GP500-G-AS
GP500-CG-AS
GP1000-ARL-AS

FRONT VIEW

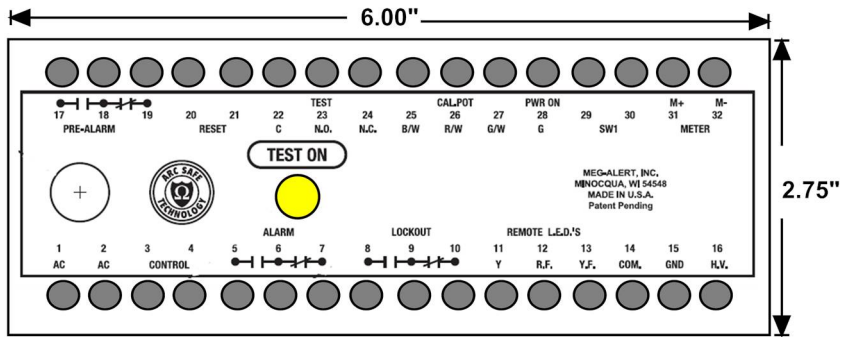

SIDE VIEWS

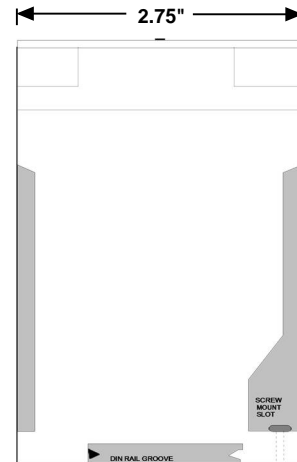
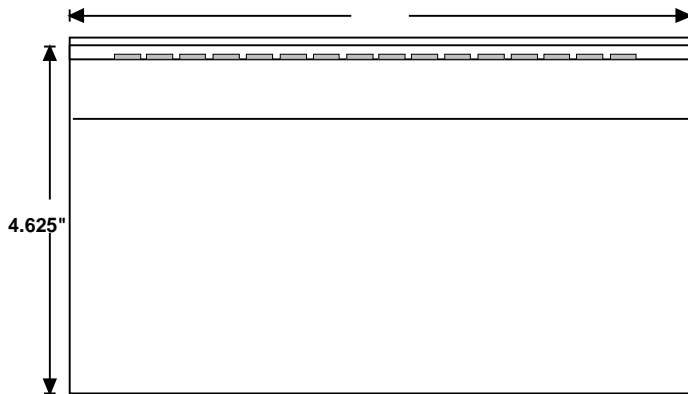

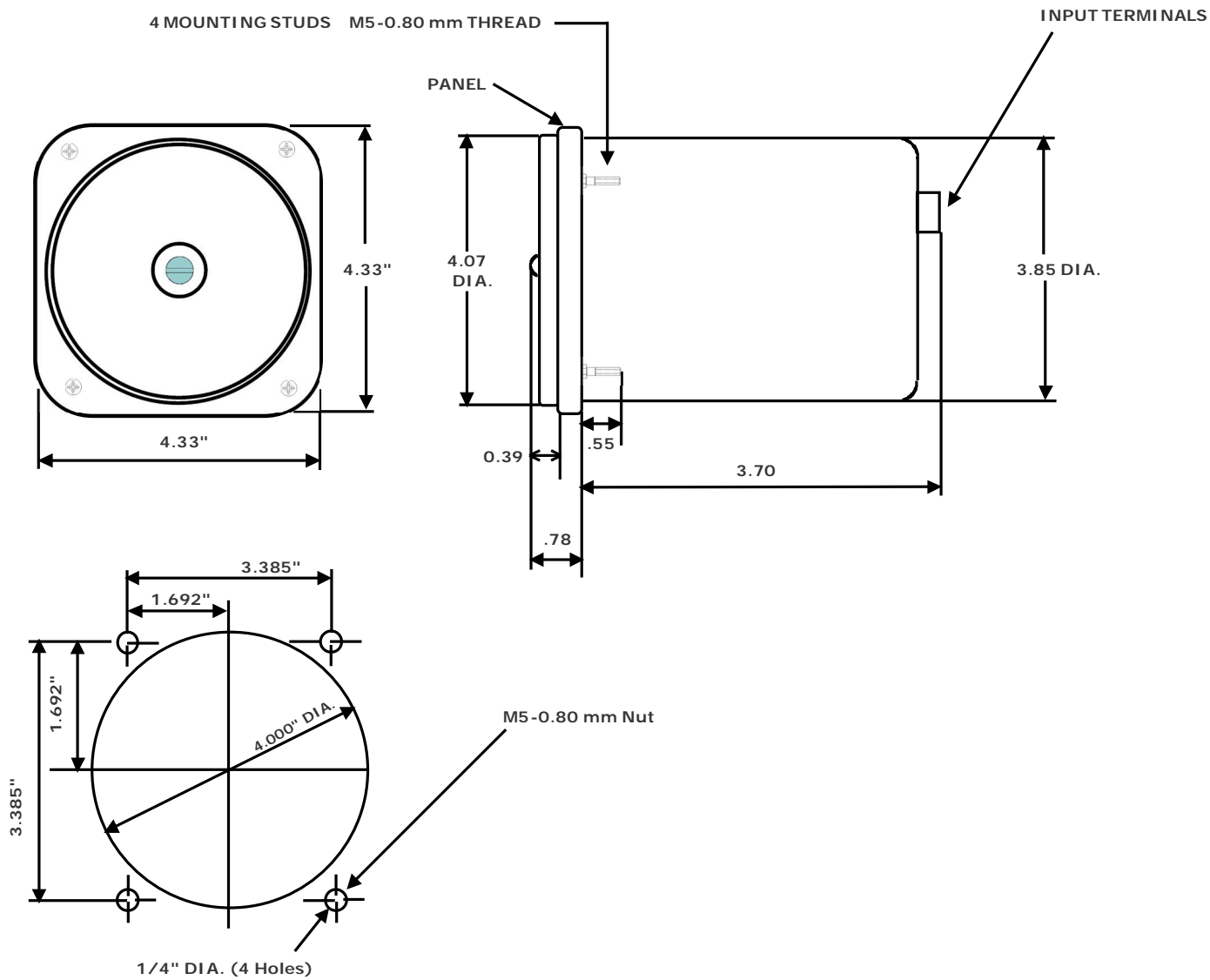

1 % Switchboard Meter Dimensions GP7000 Series 	DRAWN BY		DATE
	KM Delamater		2/5/2018
	CHECKED R. Zelm	SCALE None	SHEET NO. 1