

※To prevent irregular winding of the wire rope around the drum, keep the fleet angle 2 degrees or less.
Please install the pulley 7ft or more away from the drum on the center line of the drum.
※The value of specified "Wire Rope Tension" on this drawing is for the standard layer or less.
The value of the "Wire Rope Tension" must be decreased accordance with the ratio of the actual winding layers, if it exceeded.

Specifications		(The wire rope composition is a manufacturer recommendation.)		
Load Rating	1,100 lbs (=500 kgf)	Handle Force	Handle Length	Number of Wire Rope Winding Layer
Wire Rope Tension	5th Layer(Standard Layer)		9 27/32"	
Drum Capacity	Wire Rope 6-Layer Windings φ 1/4" (6 × 36) × 131 ft		Wire Rope Tension	3rd Layer 31.7lbs(=14.4kgf)
Gear Ratio	1/8.9		1,100lbs	5th Layer 39.0lbs(=17.7kgf)
Effective Handle Length	9 27/32" (Maximum)	Standard Accesories		One Handle
Weight	34 lbs (Winch + Handle)	Painting		One Hex Wrench for Anchoring the Wire Rope

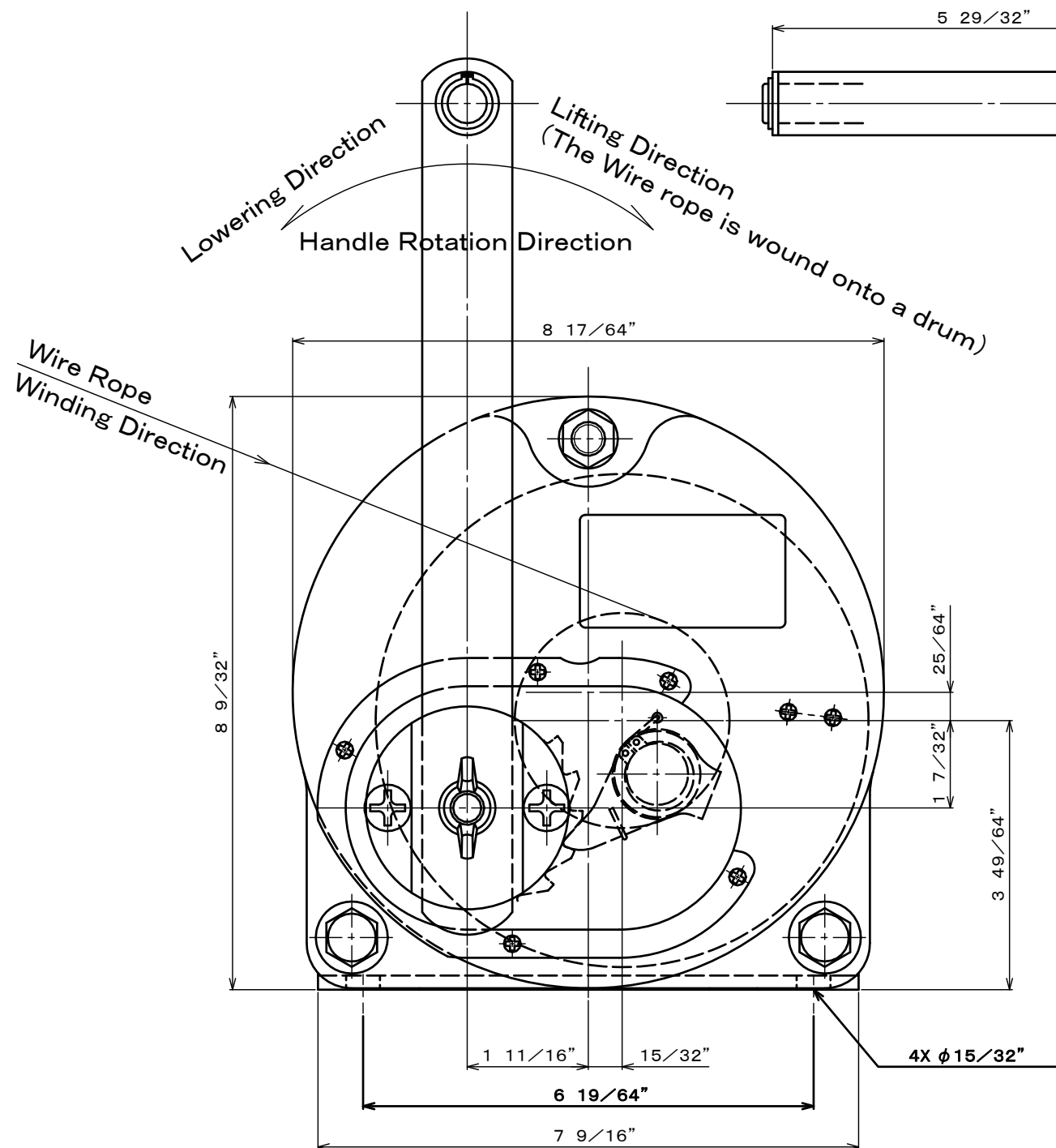

Special Specifications
○The parts for hot dip galvanizing are : gear case, gear case cover, drum, side frame, bed plate, clutch cover and handle arm.
○The stay bolt, bolts, screws, nuts, retaining ring and spring are made of SUS-304.
○Chromate plating is applied to the stopper, clutch and handle holder and then Roval Silver is painted over it.
○The shaft is chromate plated and only the tip of the shaft is painted with Roval Silver.

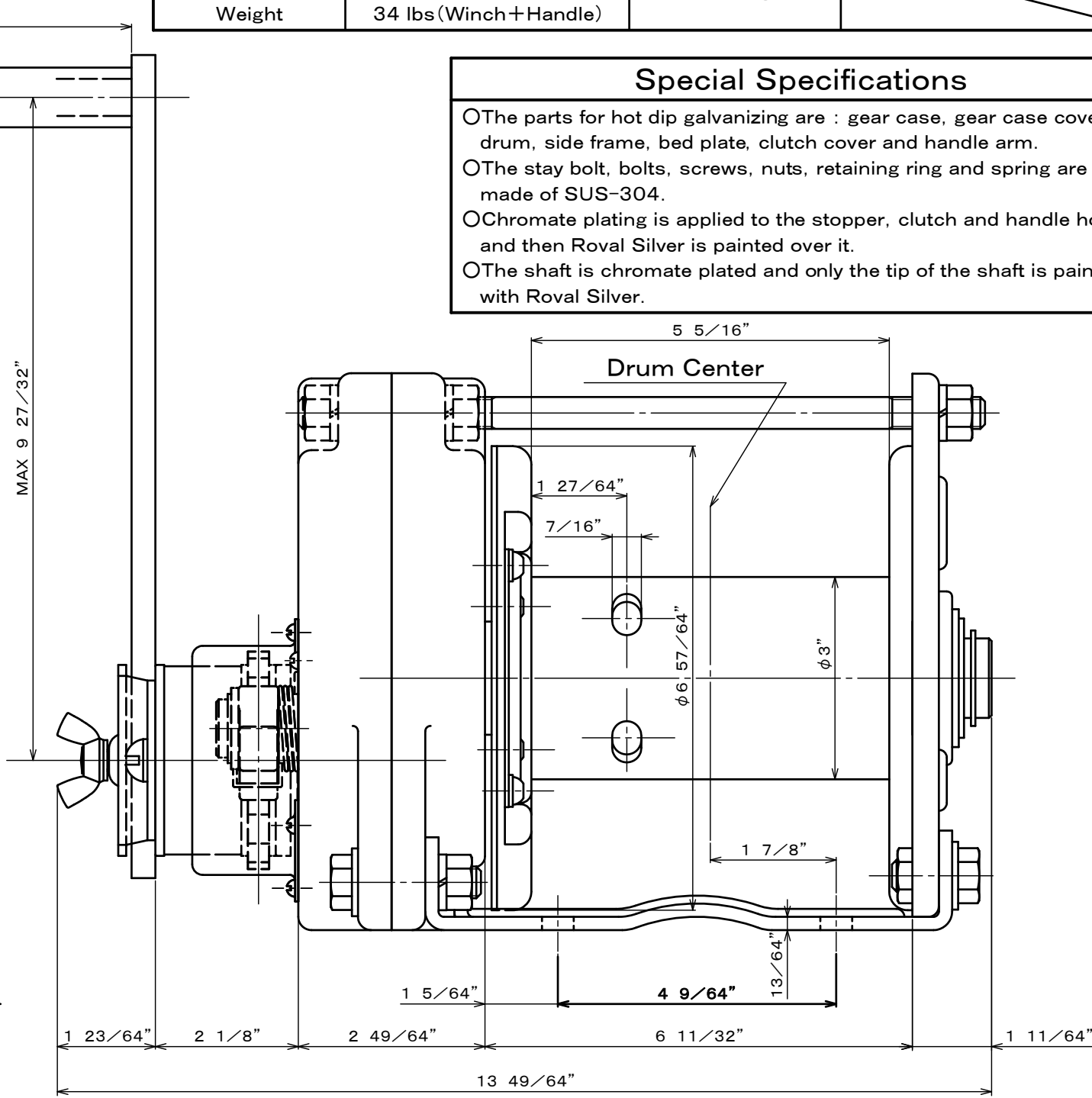

4 x		図面番号/DRAWING No. GM5GSSI-180402-01U	改訂番号 REVISION No. 00	お客様/CUSTOMER	符号 MARK	項目 PARTICULARS	材料 MATERIAL	数量 QTY	単体重量(kg) PER ONE WEIGHT	合計重量(kg) TOTAL WEIGHT	備考 REMARKS
3 x		承認/APPROVED	検図/CHECKED	作成/DRAWN	図面名/TITLE MAXPULL WINCH CORROSION RESISTANT AND SALT RESISTANT (HOT DIP GALVANIZING) STOPPER ARMLESS ROTATING MODEL GM-5-GS-SI		投影法/PROJECTION METHOD 第三角法 THIRD ANGLE PROJECTION	尺度/SCALE	台数/QTY		
2 x		設計部 '18.04.04 米澤	設計部 '18.04.04 松嶺	設計部 '18.04.04 武松			MAXPULL				
1 x							MAXPULL MACHINERY & ENGINEERING CO., LTD.		マックスプル工業株式会社		
改訂/REVISION											