

TOTO®

CWT4494049CMFGA#MS

SP WASHLET®+ SX Wall-Hung Toilet, 1.28GPF & 0.9GPF

FEATURES

SP Bowl

- DYNAMAX TORNADO FLUSH® system, high efficiency (1.28GPF/0.9GPF)
- CEFIONTECT® ceramic glaze minimizes waste from sticking to porous ceramic surfaces
- Universal Height

WASHLET+ SX

- Concealed supply connection for seamless installation
- Gentle aerated, warm water, dual action spray with adjustable pressure and oscillating pulsating features
- Adjustable variable temperature for spray and seat
- Water PREMIST of bowl before each use
- Automatic air deodorizer
- Convenient slim wireless remote, with illuminated touch pad
- Auto Flush

DuoFit In-Wall Tank

- Dual flushing system, high-efficiency (1.28 GPF/4.8 LPF & 0.9 GPF/3.4 LPF) Avg. flush 1.1 GPF
- Adjustable 15" -19" mounting height
- Saves up to 9" of floor space compared to standard floor-mounted toilet
- Supports up to 880lbs
- Commercial 2" x 6" or optional residential installation with 2" x 4" wall studs with waste outlet kit

KIT COMPONENTS

- CT449CFGT60#01
SP Wall-Hung Toilet
- SW4049AT60#01
WASHLET+ SX
- WT173MA
In-Wall Tank System (1.28 GPF/0.9 GPF)
- YT920#MS
Matte Silver Basic Square Push Plate

Available Options

- YT920#WH - White Matte Basic Square Push Plate
- YT930#WH - White Matte Basic Round Push Plate
- YT930#MS - Matte Silver Basic Round Push Plate
- YT970#SS - Stainless Steel Wall Square Push Plate
- YT980#SS - Stainless Steel Wall Round Push Plate

COLORS/FINISHES

- Standard
#01 Cotton



 **DYNAMAX
TORNADO FLUSH**

 **CEFIONTECT**

 **Auto Flush**

PRODUCT SPECIFICATION

The two-piece high efficiency DYNAMAX TORNADO FLUSH system toilet shall be 1.0 GPF/3.8 LPF. Toilet shall have high profile tank, elongated front bowl and chrome trip lever. Toilet shall be universal height CST449CFG model shall have CEFIONTECT ceramic glaze. Toilet shall be TOTO Model CST449CFG_____.

CODES/STANDARDS

- Meets and exceeds ASME A112.19.2/CSA B45.1
- Certifications: IAPMO (cUPC), EPA WaterSense, State of Massachusetts, City of Los Angeles, and others
- Code Compliance: UPC, IPC, NSPC, NPC Canada, and others
- Legislative Compliance: California AB715, California Green Building Code, City of Los Angeles Water Efficiency Ordinance
- ADA compliant



CWT4494049CMFGA#MS

SP WASHLET®+ SX Wall-Hung Toilet, 1.28GPF & 0.9GPF

DIMENSIONS

YT920

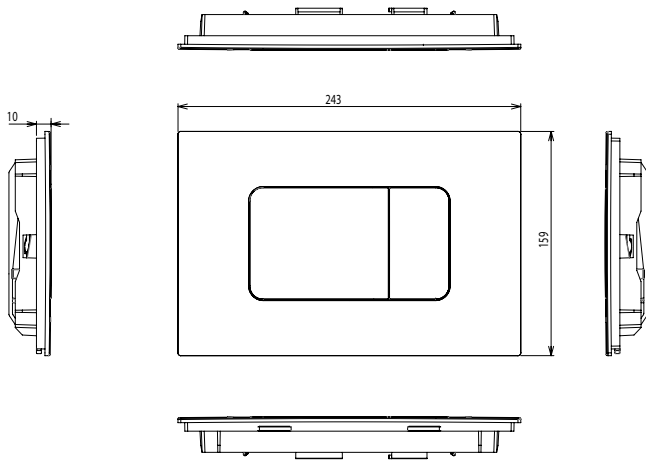

WT173MA

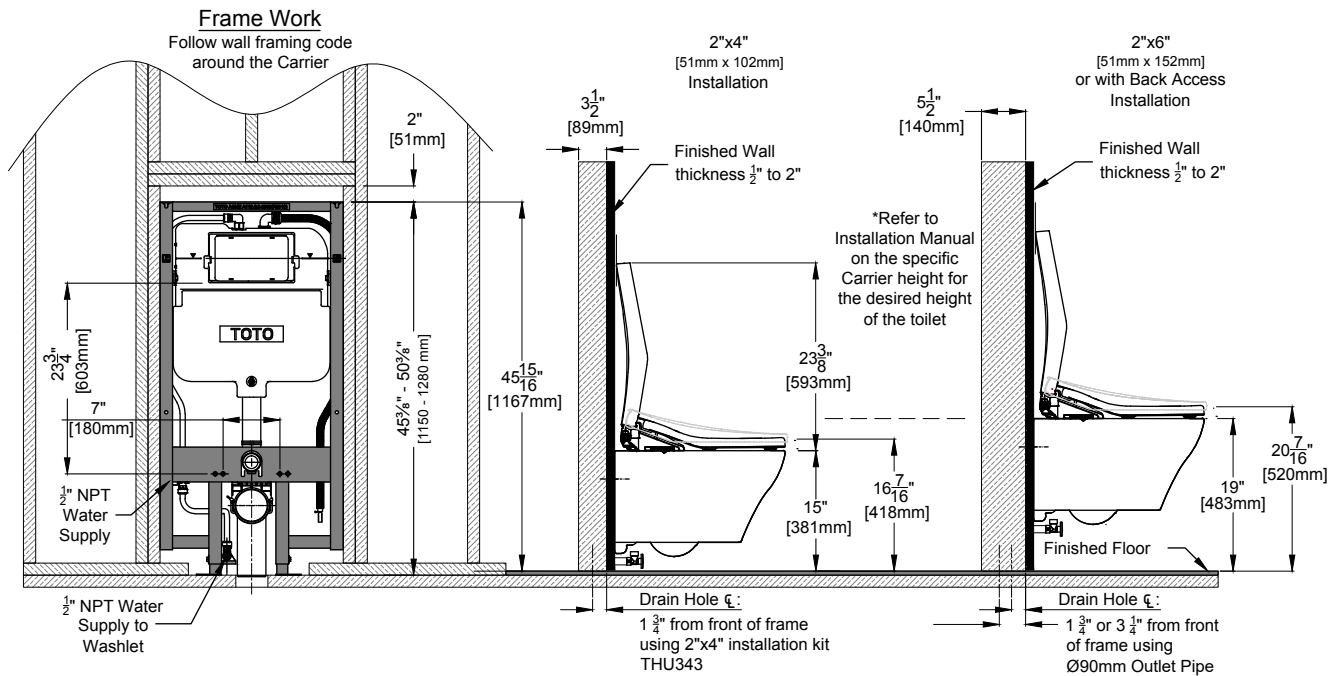

TOTO

These dimensions and specifications are subject to change without notice