



Technical Data Sheet

Alpha 20



File No. E471457



Alpha 20 is a compact multifunction instrument which Measures important electrical parameters in 3 phase 4 Wire and 3 phase 3 Wire Network & replaces the multiple analog panel meters.

Special Features

- MODBUS (RS-485) Communication (optional)
- Pulse/Limit Switch output (optional)
- 3 Line 4 Digits ultra bright LED Display (up to 9999)
- On site Programmable CT/PT Ratios
- User selectable CT Secondary 1A/5A
- User selectable PT Secondary from 100 VLL to 500 VLL
- Programmable Energy format & Energy rollover count
- Wide auxillary Power Supply which can accept any input between 40V - 300V AC/DC

Application

Alpha 20 Measures important electrical parameters in 3 phase 4 Wire and 3 phase 3 Wire Network & replaces the multiple analog panel meters. It measures electrical parameters like AC Voltage, AC Current, Frequency, Active, Reactive, Apparent Power, Import Export Energy & many more.

Product Features

| | | | |
|--|--|--|---|
| On site programmable PT/CT ratios | It is possible to program primary of external potential Transformer (PT), primary of external Current Transformer (CT) on site via front panel keys by entering into Programming mode. | Optional Pulse Output / Limit switch (Relay output) | The instrument can be programmed as Pulse output or Limit switch. |
| User selectable CT Secondary 5A /1A | The secondary of external Current Transformer (CT) can be programmed on site to either 5A or 1A using front panel keys. | Pulse Output | The optional pulse output is a potential free, very fast acting relay contact which can be used to drive an external mechanical counter for energy measurement. |
| User selectable PT Secondary | The secondary of external Potential Transformer (PT) can be programmed on site from 100VLL to 500VLL using front panel keys. User can set the display in auto scrolling mode or fixed screen mode using front panel keys. | Limit Switch | The instrument will trip the relay if the programmed parameter exceeds the programmed Trip Limits. |
| Low back depth | The instrument has very low back depth (behind the panel) of less than 55 mm (Without output option). | Optional MODBUS (RS485) Output | The optional Modbus output enables the instrument to transmit all the measured parameters over standard MODBUS (RS-485). |
| Four function keys | Using the four function key, it is possible to go desired parameter screen instantly.. | Configuration of Instrument via MODBUS | The instrument setting can be configured locally via front panel keys by entering into the programming mode or remotely via MODBUS RS-485 Note: The MODBUS communication parameters can only be set locally via front panel keys in programming mode. |
| Demand Measurement | Measures & Displays Current Demand, kVA Demand, kW Import Demand, kW Export Demand. Any of the parameters can be assigned to optional Limit switch. | Storage of parameters possible | The instrument stores minimum and maximum values for System Voltage, System Current, Run Hour, ON Hour & number of Interrupts. Every 60 sec stored values are updated. |
| 3 line 4 digits LED display | Simultaneous display of 3 Parameters. | Enclosure Protection for dust and water | Conforms to IP 50 (for front face) & IP 20 (for back) IP 65 (for front with seal) as per IEC60529. |
| RPM Measurement | The instrument display Rotation per minutes for generator applications. Number of poles can be set on site depending upon application requirement. | EMC Compatibility | Compliance to International standard IEC 61326. |
| Energy Count Storage | In case of power failure, the instrument memorizes the last energy count. Every 1 min, the instrument updates the energy counter in the non-volatile memory. | Interference Emission | IEC 61326-1 : 2005, Class A |
| User selectable 3 phase 3 Wire or 4Wire or Single phase Network | User can program on site the network connection as either 3 Phase 3 Wire or 4 Wire or single phase network using front panel keys. In case of self powered configuration either 3 Phase 4 wire or single phase network is available. | Interference Immunity | IEC 61326-1 : 2005 |
| Onsite selection of Auto scroll / Fixed Screen | User can set the display in auto scrolling mode or fixed screen mode using front panel keys. | Electrostatic discharge contact /air. (ESD) | IEC 61000-4-2 -- 4kV/8kV |
| | | EM Field | IEC 61000-4-3 -- 10 V/m (80 MHz to 1 GHz) - 3 V/m (1.4 Ghz to 2 GHz) -- 1 V/m (2 GHz to 2.7 GHz) |

Product Features

| | |
|---|---|
| True RMS measurement | The instrument measures distorted wave form up to 15th Harmonic. |
| Energy Measurement (Import & Export) | Active Energy (kWh), Reactive Energy (kVARh), Apparent Energy (kVAh). Any of the parameters can be assigned to optional Pulse output. |
| Programmable Energy format & Energy rollover count | Customer can assign the format for energy display on MODBUS (RS-485) in terms of W, kW or MW. Additional to this, customer can also set a rollover count from 7 to 14 digits depending on the energy format, after which the energy will roll back to zero. |

| | |
|---|---|
| Burst | IEC 61000-4-4 -- 2 kV (5/50 ns, 5 kHz) |
| Surge | IEC 61000-4-5 -- 1 kVLL / 2 kVLN. |
| Conducted RF | IEC 61000-4-5 -- 3 V (150 kHz to 80 MHz) |
| Rated Power Frequency magnetic Field | IEC 61000-4-8 -- 30 A/m |
| Voltage dip | IEC 61000-4-11 -- 0% during 1 cycle. -- 40% during 10/12 cycles. -- 70% during 25/30 cycles. |
| Short interruptions cycles. | IEC 61000-4-11 -- 0% during 25/30 cycles. 25 cycles for 50 Hz test. 30 cycles for 60 Hz test. |

Technical Specifications

| Reference conditions for Accuracy | |
|-----------------------------------|---|
| Reference temperature | 23°C +/- 2°C |
| Input waveform | Sinusoidal (distortion factor 0.005) |
| Input frequency | 50 or 60 Hz ±2% |
| Auxiliary supply voltage | Rated Value ±1% |
| Auxiliary supply frequency | Rated Value ±1% |
| Voltage Range | 20... 100% of Nominal Value. |
| Current Range | 10... 100% of Nominal Value. |
| Power | Cos phi / sin phi = 1 for Active / Reactive Power & Energy. 10... 100% of Nominal Current & 20... 100% of Nominal Voltage. |
| Power Factor / Phase Angle | 40... 100% of Nominal Current & 20... 100% of Nominal Voltage. |

| Accuracy | |
|-----------------|------------------------|
| Voltage | ± 1% of Nominal Value. |
| Current | ± 1% of Nominal Value. |
| Frequency | 0.5% of mid frequency |
| Active Power | ± 1% of Nominal Value. |
| Re-Active Power | ± 1% of Nominal Value. |
| Apparent Power | ± 1% of Nominal Value. |
| Active Energy | ± 1% |
| Reactive Energy | ± 1% |
| Apparent Energy | ± 1% |
| Power Factor | 2% of Unity |
| Phase angle | 2% of range |

Measurement error is normally much less than error specified above. Variation due to influence quantity is less than twice the error allowed for reference condition.

Dimension Details

With optional MODBUS / Limit switch

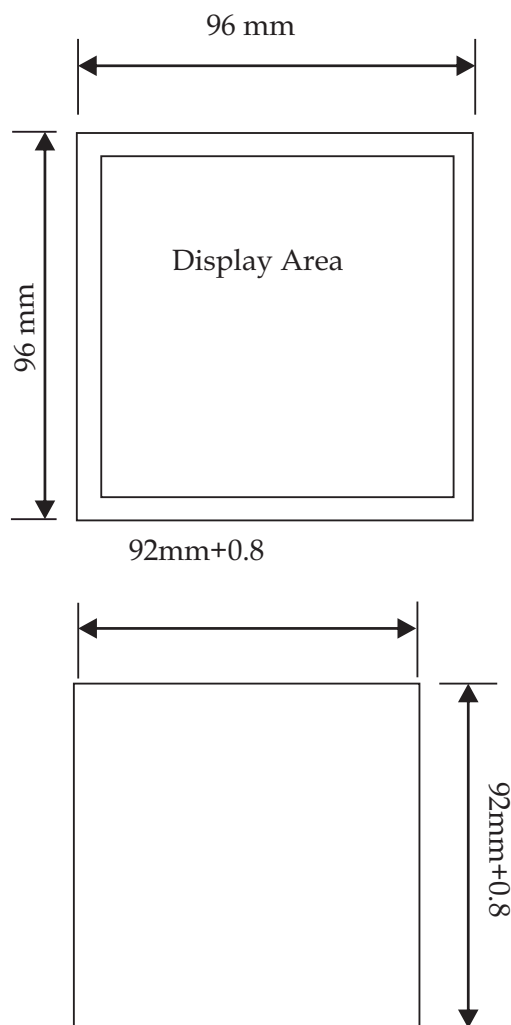

Technical Specifications

| Input Voltage | |
|--------------------------------|--|
| Nominal input voltage (AC RMS) | Phase -Neutral 290V L-N , Line-Line 500V L-L |
| Max continuous input voltage | 120% of rated value |
| Nominal input voltage burden | < 0.3 VA approx. per phase (For external auxiliary meter) |
| System PT secondary values | 100VLL to 500VLL programmable on site. |
| System PT primary values | 100VLL to 692kVLL programmable on site. |

| Input Current | |
|------------------------------|--|
| Nominal input current | 5A / 1A AC RMS |
| System CT secondary values | 1A & 5A programmable on site |
| System CT primary values | From 1A up to 9999A (for 1 or 5 Amp) |
| Max continuous input current | 120% of rated value |
| Nominal input current burden | < 0.2 VA approx. per phase |

| Auxiliary Supply | |
|------------------|--|
| External Aux | 40 V - 300V AC-DC (± 5 %) |
| Self powered | input voltage range from 80% to 100% of Rated value. (Self powered meter is available only in 3Phase 4 Wire and Single Phase network.) Auxiliary input is derived from Phase 1 (R phase) |
| Frequency range | 45 to 65 Hz |
| VA burden | < 4 VA Approx. |

| Overload Withstand | |
|--------------------|--|
| Voltage | 2 x rated value for 1 second, repeated 10 times at 10 second intervals |
| Current | 20x rated value for 1 second, repeated 5 times at 5 min intervals |

| Operating Measuring Ranges | |
|---------------------------------|-----------------------------|
| Voltage Range With External Aux | 10... 120% of rated value |
| Voltage Range With Self Power | 80... 120% of rated value |
| Current Range | 10 ... 120% of rated value |
| Frequency | 45...65 Hz. |
| Power Factor | 0.5 Lead ... 1 ... 0.5 Lag. |

Dimension Details

With optional MODBUS / Limit switch

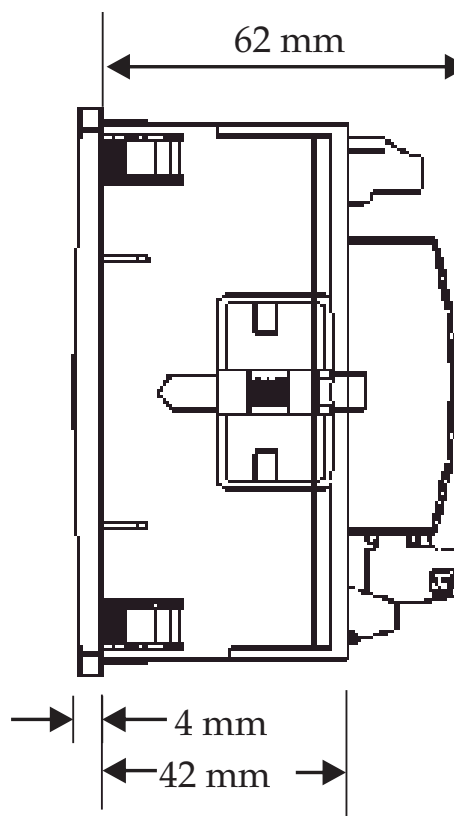
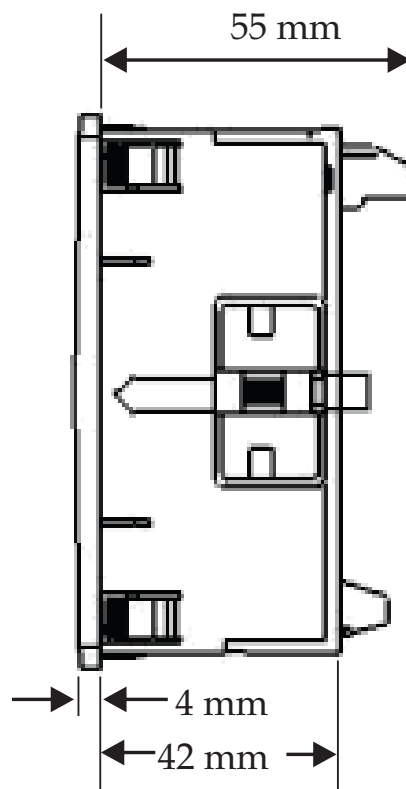

Technical Specifications

| Limit Switch (Relay) | |
|---------------------------------------|--|
| Switching Voltage & Current for Relay | 240 VDC ,5 A (1NO+1NC) |
| Influence of Variations | |
| Temperature coefficient | 0.025%/°C for Voltage 0.05%/°C for Current |
| Display update rate | |
| Response time to step input | 1 sec approx. |
| Applicable Standards | |
| EMC | IEC 61326-1: 2005 |
| Safety | IEC 61010-1-2001 , Permanently connected use |
| IP for water & dust | IEC60529 |
| Safety | |
| Pollution degree | 2 |
| Installation category | III |
| High Voltage Test | 4.7 kV DC, for 1 minute between Aux. and measuring inputs |
| Environmental | |
| Operating temperature | -20 to +70°C |
| Storage temperature | -30 to +80°C |
| Relative humidity | 0 to 95% non condensing |
| Warm up time | Minimum 3 minute |
| Shock | 15g in 3 planes |
| Vibration | 10... 55 Hz, 0.15mm amplitude |
| Enclosure | |
| Front | IP 50 |
| Front with seal (Option) | IP 65 |
| Back | IP 20 |
| Dimensions and Weights | |
| Bezel size | 96 mm x 96 mm DIN 43 718. |
| Panel cut-out | 92 +0.8 mm x 92 + 0.8 mm. |
| Overall depth | 55 mm.(without output option) |
| Panel Thickness | 1 - 3 mm for self clicking, 1 - 6 mm for swivel screws. |
| Weight | 320 gm. Approx.(with output option) |

Installation

Easy Clip in Installation on Panel.

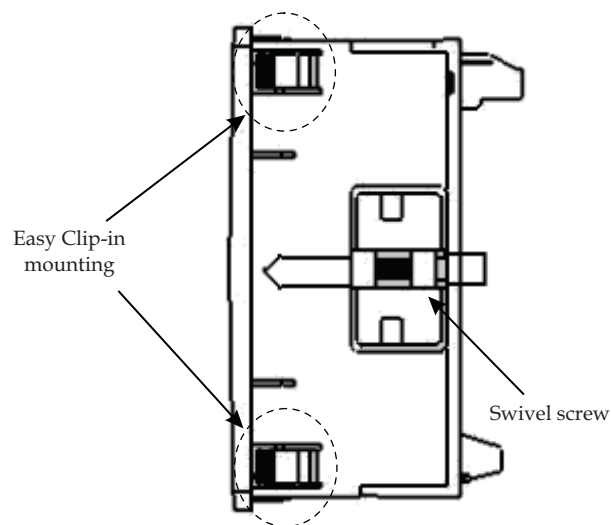

Panel Thickness : 1 - 3 mm for self clicking,
1 - 6 mm for swivel screws.

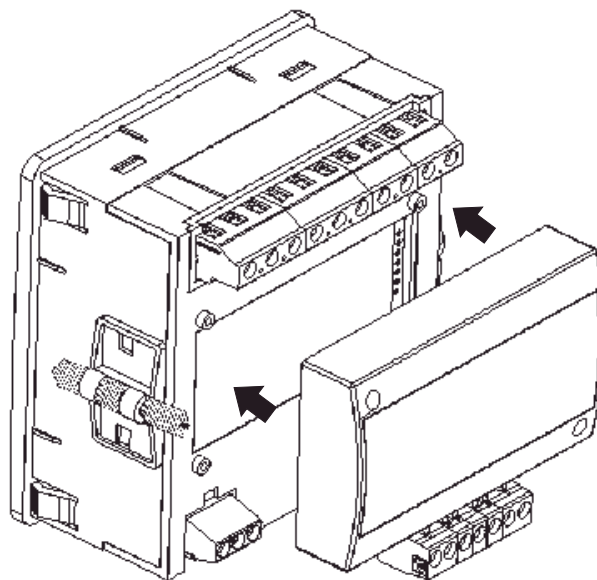

Optional Limit Switch pluggable module.

Technical Specifications

Pulsed Output Option

Energy (can be programmed for different energy parameters simultaneously)

| | |
|---------------------------------------|--------------|
| Relay contact | (1NO+1NC) |
| Switching Voltage & current for Relay | 240 VDC ,5 A |

Default pulse rate divisor

| | | |
|------------------------|---------------------------|--------------------------|
| 1 per Wh (up to 3600W) | 1 per kWh (up to 3600kWh) | 1 per MWh (above 3600kW) |
|------------------------|---------------------------|--------------------------|

Other Pulse rate divisors (applicable only when Energy on RS485 is in W)

| | | | |
|------|-----------------------------|--------------------------------|-------------------------------|
| 10 | 1 per 10 Wh (up to 3600W) | 1 per 10 kWh (up to 3600kWh) | 1 per 10 MWh (above 3600kW) |
| 100 | 1 per 100 Wh (up to 3600W) | 1 per 100 kWh (up to 3600kWh) | 1 per 100 MWh (above 3600kW) |
| 1000 | 1 per 1000 Wh (up to 3600W) | 1 per 1000 kWh (up to 3600kWh) | 1 per 1000 MWh (above 3600kW) |

Pulse Duration : 60 msec, 100 msec, 200 msec.

Above options are also applicable to Apparent and Reactive Energy.

Electrical Connections

| | Self Powered Aux | External Powered Aux |
|---|------------------|----------------------|
| 3 Phase 4 Wire Unbalanced Load | | |
| 3 Phase 3 Wire Unbalanced Load | Not Applicable | |
| 1 Phase 2 Wire | | |

*Note: For Measurement of parameters, Voltage must be present between terminal 2 & 11 for single phase or 3 phase 4 wire network and between terminal 2 & 5 or 2 & 8 for 3 phase 3 wire network.

Rear Connection

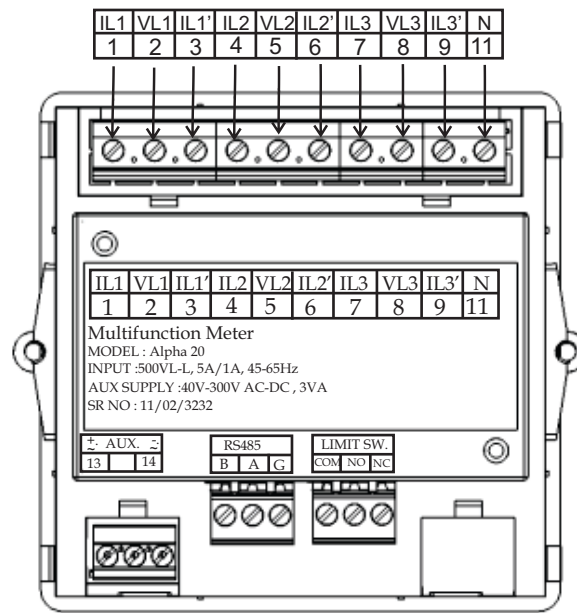

Parameter measurement and Display

| Sr No | Parameter | 3 Phase 4 Wire | 3 Phase 3 Wire | 1 Phase 2 Wire |
|-------|---|----------------|----------------|----------------|
| 1. | System Volts | ✓ | ✓ | ✓ |
| 2. | System Current | ✓ | ✓ | ✓ |
| 3. | Volts R-N (Phase Voltage for Single phase) | ✓ | ✗ | ✓ |
| 4. | Volts Y-N | ✓ | ✗ | ✗ |
| 5. | Volts B-N | ✓ | ✗ | ✗ |
| 6. | Volts R-Y | ✓ | ✓ | ✗ |
| 7. | Volts Y-B | ✓ | ✓ | ✗ |
| 8. | Volts B-R | ✓ | ✓ | ✗ |
| 9. | Current R (Phase Current for Single phase) | ✓ | ✓ | ✓ |
| 10. | Current Y | ✓ | ✓ | ✗ |
| 11. | Current B | ✓ | ✓ | ✗ |
| 12. | Frequency | ✓ | ✓ | ✓ |
| 13. | System Active Power (kW) | ✓ | ✓ | ✓ |
| 14. | Active Power R (Phase Power for Single phase) (kW) | ✓ | ✗ | ✓ |
| 15. | Active Power Y (kW) | ✓ | ✗ | ✗ |
| 16. | Active Power B (kW) | ✓ | ✗ | ✗ |
| 17. | System Re-active Power (kVAr) | ✓ | ✓ | ✓ |
| 18. | Re-active Power R (Phase Power for Single phase) (kVAr) | ✓ | ✗ | ✓ |
| 19. | Re-active Power Y (kVAr) | ✓ | ✗ | ✗ |
| 20. | Re-active Power B (kVAr) | ✓ | ✗ | ✗ |
| 21. | System Apparent Power (kVA) | ✓ | ✓ | ✓ |
| 22. | Apparent Power R (Phase Power for Single phase) (kVA) | ✓ | ✗ | ✓ |
| 23. | Apparent Power Y (kVA) | ✓ | ✗ | ✗ |
| 24. | Apparent Power B (kVA) | ✓ | ✗ | ✗ |
| 25. | System Phase Angle | ✓ | ✓ | ✓ |
| 26. | System Power Factor | ✓ | ✓ | ✓ |
| 27. | Power Factor R | ✓ | ✗ | ✓ |

✓ - Available ✗ - Not available

Parameter measurement and Display

| Sr No | Parameter | 3 Phase 4 Wire | 3 Phase 3 Wire | 1 Phase 2 Wire |
|-------|---------------------------------------|----------------|----------------|----------------|
| 28. | Power Factor Y | ✓ | ✗ | ✗ |
| 29. | Power Factor B | ✓ | ✗ | ✗ |
| 30. | Phase Angle R | ✓ | ✗ | ✓ |
| 31. | Phase Angle Y | ✓ | ✗ | ✗ |
| 32. | Phase Angle B | ✓ | ✗ | ✗ |
| 33. | Active Energy Import (kWh) | ✓ | ✓ | ✓ |
| 34. | Active Energy Export (kWh) | ✓ | ✓ | ✓ |
| 35. | Reactive Energy Import (kVARh) | ✓ | ✓ | ✓ |
| 36. | Reactive Energy Export (kVARh) | ✓ | ✓ | ✓ |
| 37. | Apparent Energy (kVAh) | ✓ | ✓ | ✓ |
| 38. | RPM | ✓ | ✓ | ✓ |
| 39. | Max (System Voltage / System Current) | ✓ | ✓ | ✓ |
| 40. | Min (System Voltage / System Current) | ✓ | ✓ | ✓ |
| 41. | Hour Run | ✓ | ✓ | ✓ |
| 42. | ON Hour | ✓ | ✓ | ✓ |
| 43. | Number of auxiliary interrupt | ✓ | ✓ | ✓ |
| 44. | Current Demand | ✓ | ✓ | ✓ |
| 45. | kVA Demand | ✓ | ✓ | ✓ |
| 46. | kW Demand Import | ✓ | ✓ | ✓ |
| 47. | kW Demand Export | ✓ | ✓ | ✓ |
| 48. | Max Current Demand | ✓ | ✓ | ✓ |
| 49. | Max kVA Demand | ✓ | ✓ | ✓ |
| 50. | Max kW Demand Import | ✓ | ✓ | ✓ |
| 51. | Max kW Demand Export | ✓ | ✓ | ✓ |

✓ - Available ✗ - Not available

Ordering information

| | | | | | | | | |
|--|----------------------|---|---|---|----|---|---|--------|
| Product Code | AP20- | X | X | X | XX | X | X | 000000 |
| System Type | 3 Ph. (PR. 3W or 4W) | 3 | | | | | | |
| * System Type is Site selectable. ** Select code for factory default setting. | 1 Ph. | 1 | | | | | | |
| Input Voltage | 100 TO 500VL-L | | 1 | | | | | |
| Input Current | 1/5A | | | 1 | | | | |
| Power Supply | Self Aux | | | | SA | | | |
| | 40 V - 300 U | | | | EA | | | |
| | 12-48 V DC | | | | LA | | | |
| Limit switch | With Limit switch | | | | | L | | |
| | Without Limit switch | | | | | Z | | |
| RS 485 | With RS 485 | | | | | | R | |
| | Without RS 485 | | | | | | Z | |

