

# Series 97 stainless steel cylinders

Single- and double-acting, cushioned, magnetic.  
 $\varnothing$  32, 40, 50, 63 mm

SERIES 97 STAINLESS STEEL CYLINDERS



- » Clean design
- » Stainless steel AISI 304
- » Adjustable endstroke cushioning

Series 97 stainless steel cylinders can be used in critical applications where a high level of corrosion resistance is required (for example: off-shore, naval, food industries).

These cylinders are normally equipped with end-stroke cushioning which can be adjusted through a screw on the end block. In order to quieten the impact of the piston on the end block, these cylinders are also equipped with mechanical cushioning.

## GENERAL DATA

<b>Type of construction</b>	the end blocks are screwed to the tube with an intermediate Teflon ring
<b>Operation</b>	single-acting and double-acting
<b>Materials</b>	end blocks, tube, rod in stainless steel AISI 304 rod seals in PU, piston seals in NBR plastic guiding element, NSF H1-certified lubricant
<b>Type of mounting</b>	threaded front and rear locking ring pins on front cap ends rear male hinge articulated rear male hinge rear female hinge
<b>Stroke min-max</b>	25 ÷ 800 mm
<b>Operating temperature</b>	0°C ÷ 80°C (with dry air - 20°C)
<b>Operating pressure</b>	1 ÷ 10 bar
<b>Speed</b>	10 ÷ 1000 mm/sec (without load)
<b>Fluid</b>	Filtered air, without lubrication. If lubricated air is used, it is recommended to use oil ISOVG32. Once applied the lubrication should never be interrupted.

**STANDARD STROKES FOR CYLINDERS SERIES 97**

- = Single-acting
- ✕ = Double-acting

STANDARD STROKES														
∅	25	50	75	80	100	125	150	160	200	250	300	320	400	500
32	✕●	✕●	✕	✕	✕	✕	✕	✕	✕	✕	✕	✕	✕	✕
40	✕●	✕●	✕	✕	✕	✕	✕	✕	✕	✕	✕	✕	✕	✕
50	✕●	✕●	✕	✕	✕	✕	✕	✕	✕	✕	✕	✕	✕	✕
63	✕●	✕●	✕	✕	✕	✕	✕	✕	✕	✕	✕	✕	✕	✕

**CODING EXAMPLE**

<b>97</b>	<b>M</b>	<b>2</b>	<b>A</b>	<b>050</b>	<b>A</b>	<b>0200</b>	
-----------	----------	----------	----------	------------	----------	-------------	--

<b>97</b>	SERIES	
<b>M</b>	VERSIONS: M = rear male hinge S = articulated rear male hinge F = rear female hinge T = front and rear threaded end blocks A = front end block with pin	
<b>2</b>	OPERATION: 1 = single-acting, front spring 2 = double-acting, front and rear cushions 6 = double-acting, through-rod, front and rear cushions (T and A versions only)	PNEUMATIC SYMBOLS: CS06 CD09 CD13
<b>A</b>	MATERIALS: A = stainless steel AISI 304 - PU seals V = stainless steel AISI 304 - FKM seals (150°C)	
<b>050</b>	BORE: 032 = 32 mm - 040 = 40 mm - 050 = 50 mm - 063 = 63 mm	
<b>A</b>	TYPE OF DESIGN: A = standard (locking ring for end cap V + lock nut for rod U)	
<b>0200</b>	STROKE (see the table)	
	= standard V = rod seal in FKM	

**PNEUMATIC SYMBOLS**

The pneumatic symbols which have been indicated in the CODING EXAMPLE are shown below.

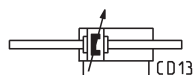

**ACCESSORIES FOR STAINLESS STEEL CYLINDERS SERIES 97**

SERIES 97 STAINLESS STEEL CYLINDERS



Foot mount Mod. B

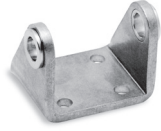

Trunnion bracket Mod. I

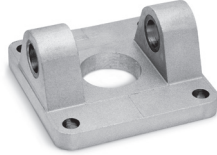

Rear female trunnion bracket Mod. C-H



Tight rear female tr. bracket Mod. CR



Male tr. bracket with swivel ball joint Mod. R



90° male tr. bracket + sw. ball joint Mod. ZCR

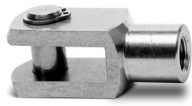

Rod fork end Mod. G-90



Swivel ball joint Mod. GA-90



Piston rod lock nut Mod. U-90



Nose nut Mod. V-97



Clevis pin Mod. S-90



Anti-rotation clevis pin Mod. SR-90



All accessories are supplied separately, except for piston rod lock nut Mod. U and nose nut Mod. V.

## Cylinders Series 97, Mod. T

With threaded front and rear end blocks



+ = add the stroke

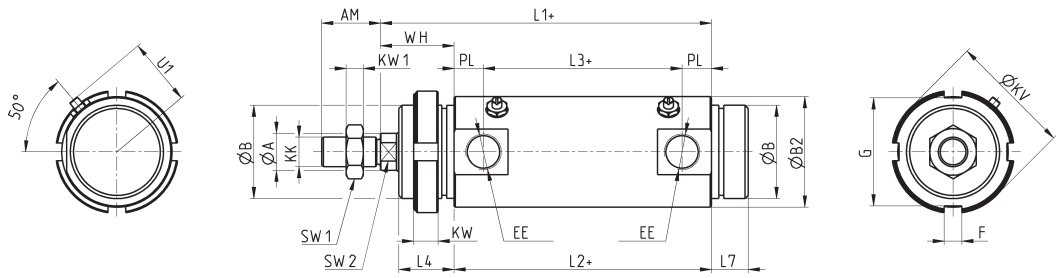

DIMENSIONS																					
Ø	ØA	AM	ØB	ØB2	EE	F	G	KK	PL	SW1	KW1	SW2	U1	WH	L1+	L2+	L3+	L4	L7	KW	ØKV
32	12	22	M30x1.5	36	G1/8	5	38	M10x1.25	9	17	6	10	23	26	120	94	76	19.5	15	7	42
40	16	24	M38x1.5	45	G1/4	6	50	M12x1.25	12	19	7	13	27	30	135	105	81	22.5	15	8	55
50	20	32	M45x1.5	55	G1/4	6	53	M16x1.5	12	24	8	17	33	37	143	106	82	28	18	10	60
63	20	32	M45x1.5	68	G3/8	6	53	M16x1.5	13	24	8	17	40	37	158	121	95	28	18	10	60

## Cylinders Series 97, Mod. T - through-rod

With threaded end blocks



+ = add the stroke once  
++ = add the stroke twice

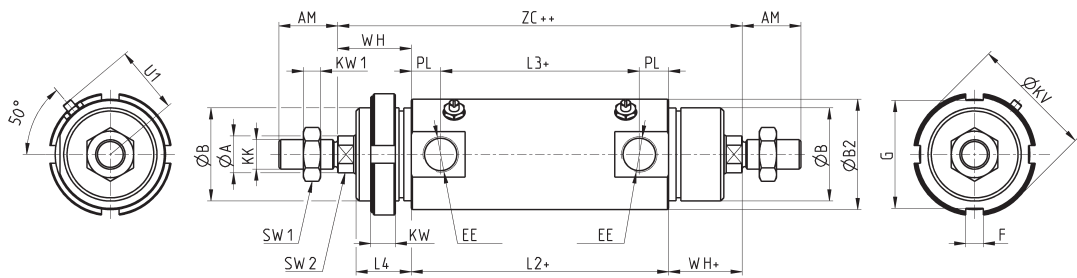

DIMENSIONS																					
Ø	ØA	AM	ØB	ØB2	EE	F	G	KK	PL	SW1	KW1	SW2	U1	WH+	L2+	L3+	L4	KW	ØKV	ZC++	
32	12	22	M30x1.5	36	G1/8	5	38	M10x1.25	9	17	6	10	23	26	94	76	19.5	7	42	146	
40	16	24	M38x1.5	45	G1/4	6	50	M12x1.25	12	19	7	13	27	30	105	81	22.5	8	55	165	
50	20	32	M45x1.5	55	G1/4	6	53	M16x1.5	12	24	8	17	33	37	106	82	28	10	60	180	
63	20	32	M45x1.5	68	G3/8	6	53	M16x1.5	13	24	8	17	40	37	121	95	28	10	60	195	

## Cylinders Series 97, Mod. M

With rear male trunnion bracket



+ = add the stroke

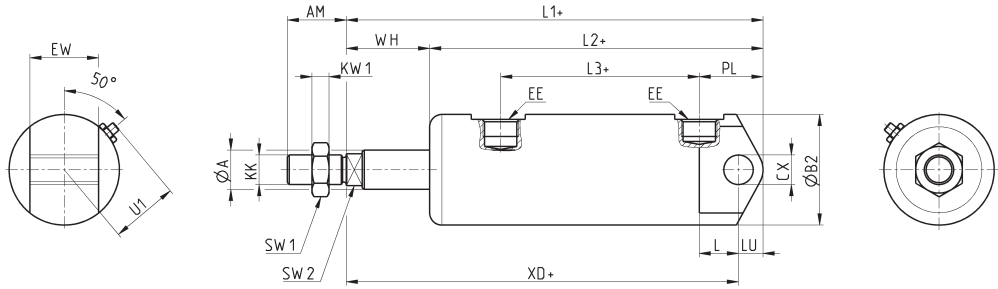

### DIMENSIONS

Ø	ØA	AM	ØB2	CX	EE	EW	KK	PL	SW1	KW1	SW2	U1	WH	L1+	L2+	L3+	L	LU	XD+
32	12	22	36	10	G1/8	26	M10x1.25	23	17	6	10	23	26	151	125	76	13	9	142
40	16	24	45	12	G1/4	28	M12x1.25	26	19	7	13	27	34	170	136	81	16	10	160
50	20	32	55	12	G1/4	32	M16x1.5	32	24	8	17	33	37	182	145	82	16.5	12	170
63	20	32	68	16	G3/8	40	M16x1.5	29.5	24	8	17	40	50	202	152	95	21	12	190

## Cylinders Series 97, Mod. S

With articulated rear male trunnion bracket



+ = add the stroke

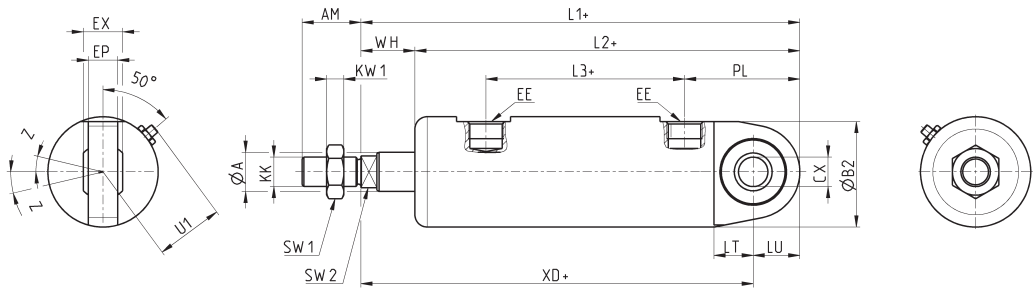

### DIMENSIONS

Ø	ØA	AM	ØB2	CX	EE	EP	EX	KK	PL	SW1	KW1	SW2	U1	WH	L1+	L2+	L3+	LT	LU	XD+	Z
32	12	22	36	10	G1/8	10.5	14	M10x1.25	37	17	6	10	23	18	157	139	76	13	15	142	13
40	16	24	45	12	G1/4	12	16	M12x1.25	47	19	7	13	27	22	179	157	81	16	19	160	13
50	20	32	55	16	G1/4	15	21	M16x1.5	49	24	8	17	33	28.5	190.5	162	82	16.5	20.5	170	15
63	20	32	68	16	G3/8	15	21	M16x1.5	60	24	8	17	40	31.5	214	182.5	95	21	24	190	15

### Cylinders Series 97, Mod. F

With rear female trunnion bracket



+ = add the stroke

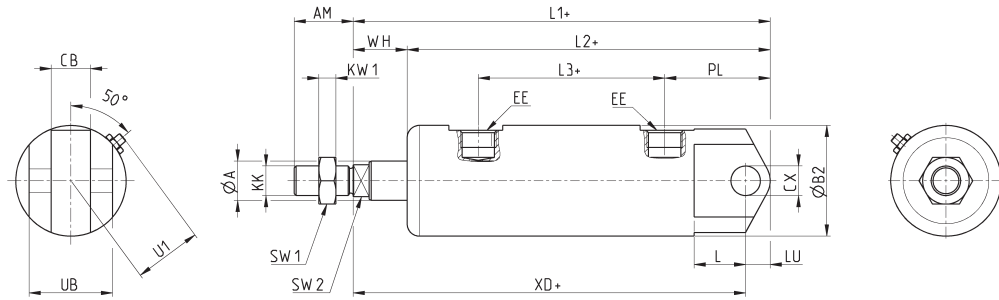

DIMENSIONS																				
Ø	ØA	AM	ØB2	CB	CX	EE	KK	PL	SW1	KW1	SW2	U1	WH	L1+	L2+	L3+	L	LU	XD+	UB
32	12	22	36	14	10	G1/8	M10x1.25	31	17	6	10	23	18	151	133	76	13	9	142	34
40	16	24	45	16	12	G1/4	M12x1.25	38	19	7	13	27	22	170	148	81	16	10	160	40
50	20	32	55	21	16	G1/4	M16x1.5	45.5	24	8	17	33	28.5	182	153.5	82	21	12	170	45
63	20	32	68	21	16	G3/8	M16x1.5	48	24	8	17	40	31.5	202	170.5	95	21	12	190	51

### Cylinders Series 97, Mod. A

With front end block with pins



+ = add the stroke

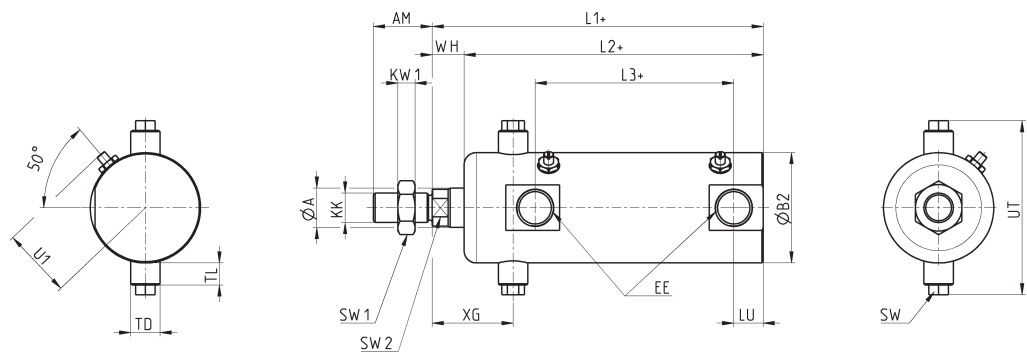

DIMENSIONS																			
Ø	ØA	AM	ØB2	EE	KK	SW	SW1	KW1	SW2	U1	WH	L1+	L2+	L3+	LU	XG	TD	TL	UT
32	12	22	36	G1/8	M10x1.25	8	17	6	10	23	9	120	111	76	9	27	10	7	58
40	16	24	45	G1/4	M12x1.25	8	19	7	13	27	13	135	122	81	12	33	12	9	71
50	20	32	55	G1/4	M16x1.5	8	24	8	17	33	18	143	125	82	12	40	14	9	81
63	20	32	68	G3/8	M16x1.5	12	24	8	17	40	22.5	158	135.5	95	13	45	16	12	104

### Foot mount Mod. B



Material: stainless steel 304

Supplied with:  
1x nut  
2x single feet

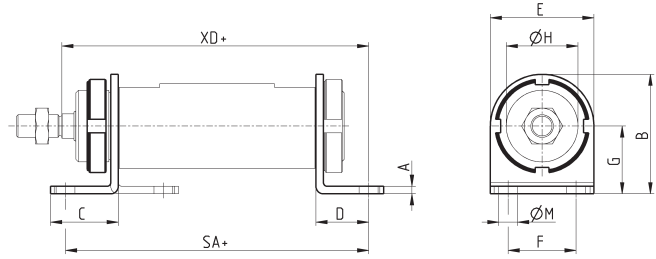

+ = add the stroke

DIMENSIONS												
Mod.	∅	A	B	C	D	E	SA+	F	G	∅H	∅M	XD+
B-97-32	32	4	53	35	24	42	142	32	32	30	7	142
B-97-40	40	4	63.5	36	28	55	161	36	36	38	10	160
B-97-50	50	5	77.5	47	32	65	170	45	45	45	10	170
B-97-63	63	5	82.5	45	32	65	185	50	50	45	10	190

### Trunnion bracket Mod. I



Material: stainless steel 304

Supplied with:  
1x female trunnion  
2x cartridges

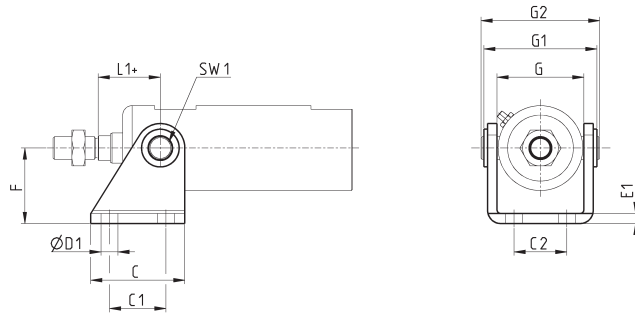

+ = add the stroke

DIMENSIONS												
Mod.	∅	C	C1	C2	∅D1	E1	F	G	G1	G2	L1+	SW1
I-97-32	32	40	24	20	7	4	35	38	50	58	27	8
I-97-40	40	50	30	28	9	5	40	46	60	71	33	8
I-97-50	50	54	34	36	9	6	45	57	74	81	40	8
I-97-63	63	65	35	43	9	6	50	70	88	104	45	12

### Rear female trunnion bracket Mod. C-H

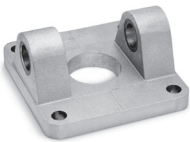

Material: stainless steel 316

Supplied with:  
1x female trunnion bracket  
4x screws

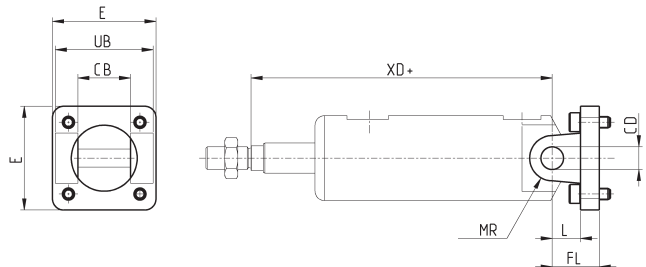

+ = add the stroke

DIMENSIONS										
Mod.	∅	CB	CD	E	FL	L	MR	UB	XD+	
C-H-90-32	32	26	10	45	22	12	10	45	142	
C-H-90-40	40	28	12	55	25	15	12	52	160	
C-H-90-50	50	32	12	65	27	17	12	60	170	
C-H-90-63	63	40	16	75	32	20	16	70	190	

### Tight rear female trunnion bracket Mod. CR



Material: stainless steel 316

Supplied with:  
1x female trunnion bracket  
4x screws

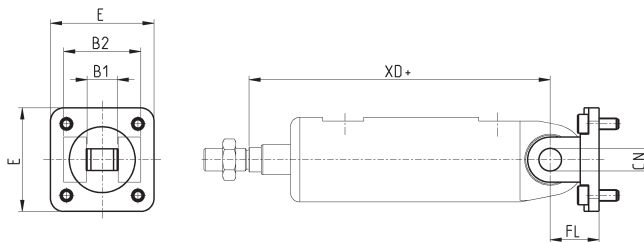

+ = add the stroke

DIMENSIONS							
Mod.	∅	B1	B2	E	CN	FL	XD+
CR-90-32	32	14	34	45	10	22	142
CR-90-40	40	16	40	55	12	25	160
CR-90-50	50	21	45	65	16	27	170
CR-90-63	63	21	51	75	16	32	190

### Male trunnion bracket with swivel ball joint Mod. R



Material: stainless steel 316

Supplied with:  
1x male trunnion bracket  
4x screws

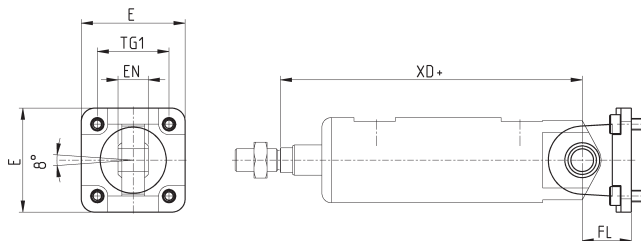

+ = add the stroke

DIMENSIONS							
Mod.	∅	E	EN	FL	TG1	XD+	
R-90-32	32	45	14	22	32.5	142	
R-90-40	40	55	16	25	38	160	
R-90-50	50	65	21	27	46.5	170	
R-90-63	63	75	21	32	56.5	190	

### 90° male trunnion bracket with swivel ball joint Mod. ZCR



Material: stainless steel 316

Supplied with:  
1x male trunnion bracket  
4x screws

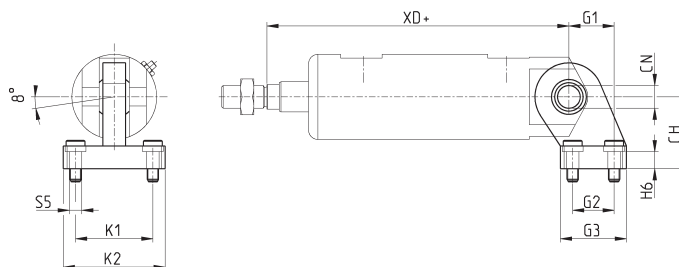

+ = add the stroke

DIMENSIONS											
Mod.	∅	CH	CN	G1	G2	G3	H6	K1	K2	S5	XD+
ZCR-90-32	32	32	10	21	18	31	10	38	51	6.6	142
ZCR-90-40	40	36	12	24	22	35	10	41	54	6.6	160
ZCR-90-50	50	45	16	33	30	45	12	50	65	9	170
ZCR-90-63	63	50	16	37	35	50	12	52	67	14	190



### Rod fork end Mod. G-90

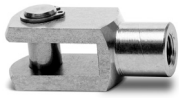

ISO 8140  
Material: stainless steel 303

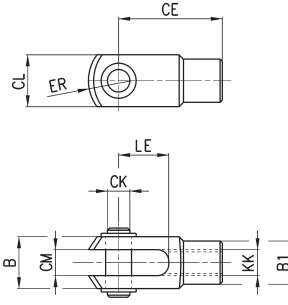

DIMENSIONS										
Mod.	∅	∅CK	LE	CM	CL	ER	CE	KK	B	∅B1
G-90-25-32	32	10	20	10	20	12	40	M10x1.25	26	18
G-90-40	40	12	24	12	24	14	48	M12x1.25	31	20
G-90-50-63	50-63	16	32	16	32	19	64	M16x1.5	39	26

### Swivel ball joint Mod. GA-90



ISO 8139  
Materials:  
- stainless steel 304 bracket  
- stainless steel 420 spherical ring  
- sintered bronze bushing

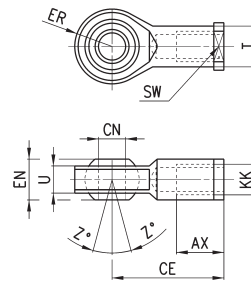

DIMENSIONS											
Mod.	∅	∅CN	U	EN	ER	AX	CE	KK	∅T	Z	SW
GA-90-32	32	10	10.5	14	14	20	43	M10x1.25	15	6.5	17
GA-90-40	40	12	12	16	16	22	50	M12x1.25	17.5	6.5	19
GA-90-50-63	50-63	16	15	21	21	28	64	M16x1.5	22	7.5	22

### Piston rod lock nut Mod. U-90



ISO 4035  
Material: stainless steel 304

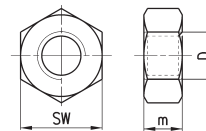

DIMENSIONS				
Mod.	∅	D	m	SW
U-90-25-32	32	M10x1.25	6	17
U-90-40	40	M12x1.25	7	19
U-90-63	50-63	M16x1.5	8	24

### Nose nut Mod. V-97



Material: stainless steel 304

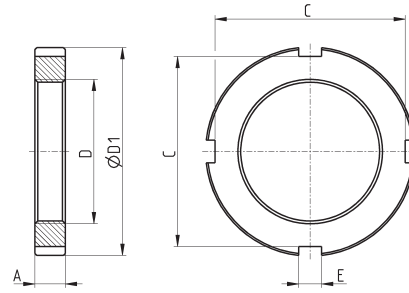

DIMENSIONS							
Mod.	Ø	A	D	ØD1	E	C	
V-97-32	32	7	M30x1.5	42	5	38	
V-97-40	40	8	M38x1.5	55	6	50	
V-97-50-63	50-63	10	M45x1.5	60	6	53	

### Clevis pin Mod. S-90



Supplied with:  
1x clevis pin in stainless steel 303  
2x seeger in steel

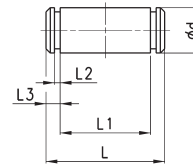

DIMENSIONS							
Mod.	Ø	Ød	L	L1	L2	L3	
S-90-32	32	10	53	46	1.1	3	
S-90-40	40	12	60	53	1.1	3	
S-90-50	50	12	68	61	1.1	3	
S-90-63	63	16	78	71	1.1	3	

### Antirotating clevis pin Mod. SR-90



Supplied with:  
1x antirotating clevis pin  
in stainless steel 316  
1x seeger in steel

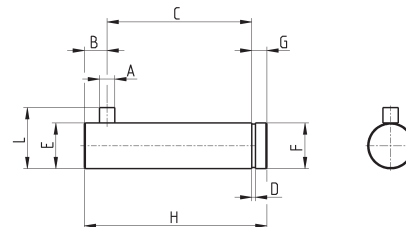

DIMENSIONS											
Mod.	Ø	A	B	C	D	E	F	G	H	L	
SR-90-32	32	3	4.5	32.5	1.1	10	9.6	4	41	14	
SR-90-40	40	4	6	38	1.1	12	11.5	4	48	16	
SR-90-50	50	4	6	43	1.1	16	15.2	5	54	20	
SR-90-63	63	4	6	49	1.1	16	15.2	5	60	20	