



ENDURANCE GAS RESTAURANT RANGE

36" Griddle / 36" Wide Gas Range



SELL SHEET

Model 36S-36GN
Shown on optional casters



SPECIFIER STATEMENT

36" wide gas restaurant range, Vulcan Model No. 36S-36GN. Fully MIG welded aluminized steel frame for added durability. Stainless steel front, sides, backriser, highshelf and 6" adjustable legs. Extra deep crumb tray with welded corners. 36" manual griddle, 3/4" thick, 4" wide grease trough. Burner knobs are cool to the touch, high temperature material. One oven: 35,000 BTU/hr. standard bakers depth oven with porcelain oven bottom and door panel, measures 27"d x 26 3/8"w x 14"h. Oven thermostat adjusts from 250°F to 500°F with a low setting. Oven is supplied with two racks, two rack guide sets, and four rack positions. Oven door is heavy duty with an integrated door hinge/spring mechanism requiring no adjustment. 3/4" rear gas connection and pressure regulator. Total input 95,000 BTU/hr.

Exterior Dimensions:

34"d x 36"w x 58"h on 6" adjustable legs

Project _____

AIA # _____ SIS # _____

Item # _____ Quantity _____ C.S.I. Section 114000

MODELS

- 36S-36GN** 1 Standard Oven / Natural Gas
- 36S-36GP** 1 Standard Oven / Propane
- 36C-36GN** 1 Convection Oven / Natural Gas
- 36C-36GP** 1 Convection Oven / Propane

STANDARD FEATURES

- Fully MIG welded frame
- Stainless steel front, sides, backriser, lift-off high shelf
- 6" stainless steel adjustable legs
- 36" manual griddle, 3/4" thick, 4" wide front grease trough
- Extra deep pull out crumb tray with welded corners
- 35,000 BTU/hr. baker's depth standard oven cavity; full size sheet pans fit side-to-side or front-to-back
- Oven thermostat adjusts from 250°F to 500°F
- Two oven racks and four rack positions
- 35,000 BTU/hr. convection oven in place of standard oven, 24"d x 26 3/8"w x 13 7/8"h (115v - 1 phase blower motor 4 amp, 6' cord and plug); full size sheet pans only fit side-to-side in convection oven; convection oven motor requires field attachment
- One year limited parts and labor warranty

ACCESSORIES (PACKAGED AND SOLD SEPARATELY)

- Extra oven rack with rack guides
- Casters (set of four)
- Leveling casters (set of four)
- Flanged feet (set of four)
- 10" stainless steel stub back
- Reinforced high shelf for mounting salamander broiler

OPTIONS (FACTORY INSTALLED)

- Thermostatically controlled griddle (snap action)
- Flame Safety device with manual spark ignition for all open top burners, thermostatic griddles and oven pilots

ENDURANCE GAS RESTAURANT RANGE - 36" Griddle / 36" Wide Gas Range



ENDURANCE GAS RESTAURANT RANGE

36" Griddle / 36" Wide Gas Range

INSTALLATION INSTRUCTIONS INSTALLATION MANUAL

1. A pressure regulator sized for this unit is included. Natural gas 5.0" W.C., propane gas 10.0" W.C.
2. Gas line connecting to range must be 3/4" or larger. If flexible connectors are used, the inside diameter must be 3/4" or larger.
3. An adequate ventilation system is required for commercial cooking equipment. Information may be obtained by visiting the National Fire Protection Association website at <https://www.nfpa.org/>. Refer to NFPA No. 96.
4. These units are manufactured for installation in accordance with ANSZ223.1A (latest edition), National Fuel Gas Code. Information may be obtained from The American Gas Association website at <https://www.aga.org/>.

5. Clearances

	Rear	Sides
Combustible	6"	10"
Standard Oven Non-Combustible	0"	0"
Convection Oven Non-Combustible	Min. 4"	0"
6. For proper combustion, install equipment on adjustable legs or casters provided with unit.
7. This appliance is manufactured for commercial installation only and is not intended for home use.

SPECIFY TYPE OF GAS WHEN ORDERING.
SPECIFY ALTITUDE WHEN ABOVE 2,000 FEET.

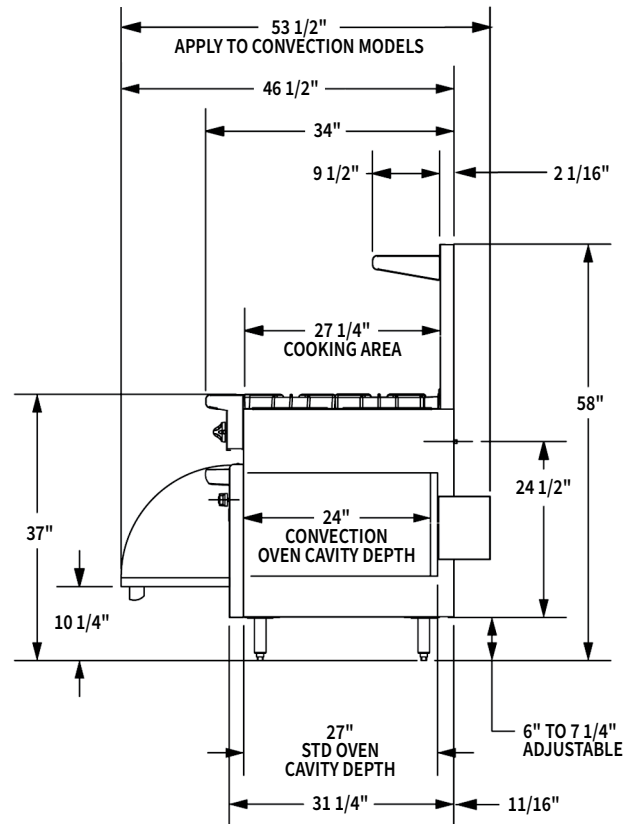
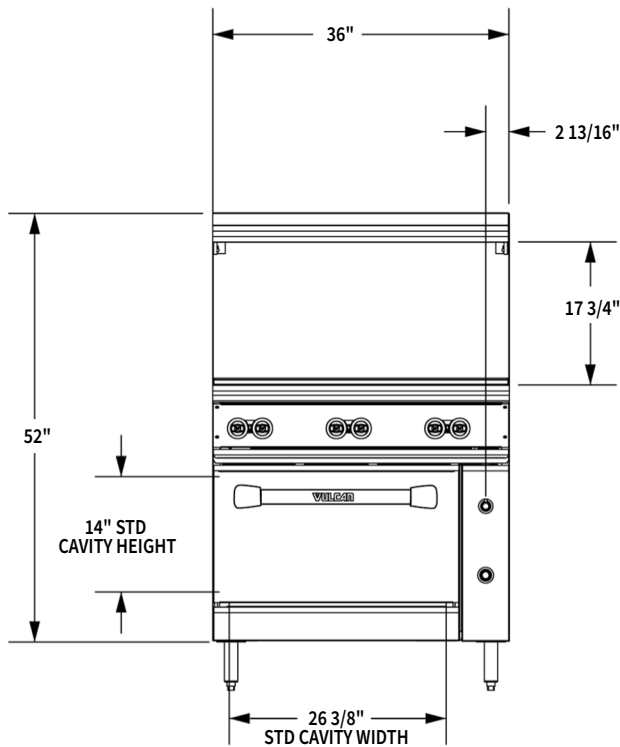

▶ CAD and/or Revit Files Available

Top Configuration	Model	Description	Total Input BTU / Hr.	Shipping Weight Lbs. / KG
	36S-36GN	1 Standard Oven / 36" Griddle / Natural Gas	95,000	610 / 277
	36S-36GP	1 Standard Oven / 36" Griddle / Propane	95,000	610 / 277
	36C-36GN	1 Convection Oven / 36" Griddle / Natural Gas	95,000	660 / 299
	36C-36GP	1 Convection Oven / 36" Griddle / Propane	95,000	660 / 299