



# PRODUCT INFORMATION BULLETIN

## AIR-EAGLE® XLT 900MHz RF Transceiver MODEL 441-40400-DC

### DESCRIPTION

The AIR-EAGLE XLT RF TRANSCEIVER IS a four I/O unit designed to transmit and receive unique signals from one or more transceivers located up to 2500 feet away (longer ranges can be achieved using external antennas). This model comes equipped with four contact inputs and four 5amp SPDT relay outputs. This allows the user to not only transmit information out but receive a confirming signal back that the operation was performed. The Air-Eagle XLT TRX is user-programmable for up eight network frequencies to allow multiple systems to operate simultaneously in the same area and utilizes spread-spectrum technology to provide the utmost security and reliability even in the noisiest RF environments. A terminal strip has been provided for interfacing with external dry contact inputs as well as dry contact relay outputs. This unit can operate remote machinery such as pumps, gates, chutes etc.

### APPROVALS

United States (FCC)	MCQ-XB900HP
Canada (IC)	1846A-XB900HP

### INSTALLATION

DISCONNECT DC Power from all equipment before installation.

1. Mount the AIR-EAGLE XLT TRANSCEIVER in a convenient location.
2. Select relay options, repeater mode, channel codes and frequency if desired (see page 2)
3. Install input & output wiring to the terminal strip
4. Install antenna to TNC connector on the right side of the enclosure.
5. Connect supplied power input cable to your external power source.

### TERMINAL STRIP WIRING

INPUTS		OUTPUTS			
1	Common Input 1	9	N/O Relay #1	15	N/O Relay #3
2	Input 1	10	C Relay #1	16	C Relay #3
3	Common Input 2	11	N/C Relay #1	17	N/C Relay #3
4	Input 2	12	N/O Relay #2	18	N/O Relay #4
5	Common Input 3	13	C Relay #2	19	C Relay #4
6	Input 3	14	N/C Relay #2	20	N/C Relay #4
7	Common Input 4				
8	Input 4				
DC INPUT					
Terminal #1		(-) 9-36VDC Input			
Terminal #2		(+) 9-36VDC Input			



\*Note – DC powered version pictured

### GENERAL OPERATION

Contact closures on inputs 1 thru 4 in the control transceiver transmit to activate relay #1 thru #4 in the remote transceiver. Inputs from the remote equipment provide closures to remote transceiver that transmit to energize relays #1 thru #4 in the control transceiver.

INPUT ACTIVATED	ACTION
"1"	Transmits channel 1 command to remote unit
"2"	Transmits channel 2 command to remote unit
"3"	Transmits channel 3 command to remote unit
"4"	Transmits channel 4 command to remote unit
INPUT CODE RECEIVED	ACTION
"1"	Relay #1 energizes, maintained momentary
"2"	Relay #2 energizes, maintained momentary
"3"	Relay #3 energizes, maintained momentary
"4"	Relay #4 energizes, maintained momentary

# AIR-EAGLE® XLT

900MHz RF Transceiver

**MODEL 441-40400-120VAC**

## RELAY, REPEATER MODE, CHANNEL CODES & FREQUENCY SETTINGS

The unit is shipped from the factory with SEL1 switches in the open positions. The relays will operate as maintained momentary, the unit is transmitting & receiving channel 1 thru 4 commands, the command transmitted will not be repeated, and it is operating on frequency 1. If you wish to change these default settings, follow the instructions on the table below.

- 1) Remove power from unit
- 2) Remove top cover.
- 3) Select desired relay operation, repeater mode, channel codes and/or network frequency using table below.
- 4) Reattach cover and apply power.
- 5) Programming is now complete.

### RELAY CONFIGURATION

SEL1 SWITCH NUMBER	OPEN	CLOSED
SW1	Relay #1 momentary (default)	Relay #1 toggle/latch
	Relay #2 momentary (default)	Relay #2 toggle/latch
SW2	Relay #3 momentary (default)	Relay #3 toggle/latch
	Relay #4 momentary (default)	Relay #4 toggle/latch

**Momentary** – Relay mimics button or input – when depressed or closed, relay will be energized; when released, relay de-energizes

**Toggle Latch** – Relay changes (and holds) its state each time the corresponding button or input is depressed or closed momentarily

### REPEATER MODE

SEL1 SWITCH NUMBER	OPEN	CLOSED
SW3	Repeater Mode OFF (default)	Repeater Mode ON

### CHANNEL CODE SET-UP

SEL1 SWITCH NUMBER	OPEN	CLOSED
SW4	Transmitting & Receiving Channel Codes 1 thru 4 (default)	Transmitting & Receiving Channel Codes 5 thru 8

### FREQUENCY SET-UP

SEL1	Network Frequency	SW5	SW6	SW7
(SW5-7)	1 (default)	OPEN	OPEN	OPEN
	2	CLOSED	OPEN	OPEN
	3	OPEN	CLOSED	OPEN
	4	CLOSED	CLOSED	OPEN
	5	OPEN	OPEN	CLOSED
	6	CLOSED	OPEN	CLOSED
	7	OPEN	CLOSED	CLOSED
	8	CLOSED	CLOSED	CLOSED

## SPECIFICATIONS

DC Input	9 - 36 VDC @ 10 Watts
Fuse Protected	1 amp
Frequency	900MHz Spread Spectrum
Relay Contacts	SPDT 5 amp @ 120VAC or 30VDC per channel
Transmitter Data	Four Dry Contact Inputs
RF Output Power	250 mW
Transceiver Range	Up to 2500 Feet w/Standard Antenna
<small>Note: Max range figures are estimates, based on free-air terrain with limited sources of interference. Actual range will vary based on transmitting power, orientation of transmitter and receiver, height of transmitting antenna, height of receiving antenna, weather conditions, interference sources in the area, and terrain between receiver and transmitter, including, but not limited to, indoor and outdoor structures such as walls, metal objects, trees, buildings, hills, and mountains.</small>	
RF Networks	Eight Independent Frequencies
Enclosure	Hinged fiberglass with window / NEMA 3, 3R, 4, 12, 13
Operating Temp	-40° F to +185° F

## DIMENSIONS

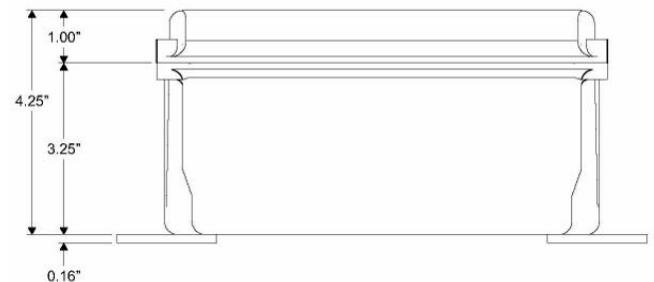
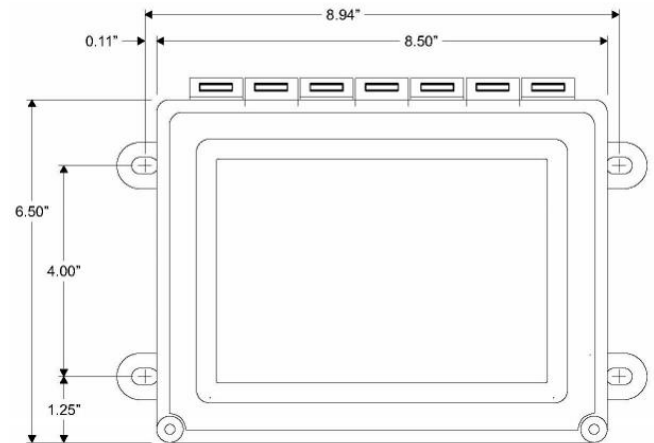

# AIR-EAGLE® XLT

900MHz RF Transceiver

**MODEL 441-40400-DC**

## ACCESSORIES

Standard Antenna (Included):	
900MHz TNC "Rubber Duck" Antenna	49-1103
Mobile/Base Antennas – Used to help achieve max range in both non line of sight and line of sight applications. - Contact BWI Eagle for recommendations	
900MHz Thru-Hole Mount Mobile Antenna	49-2101
900MHz Magnet Mount Mobile Antenna	49-2102
900MHz Omni Directional Base Antenna	49-3101
900MHz Yagi Directional Base Antenna	49-3102
High Quality Coax Cables – Used to connect external high gain antennas to control unit	
Flex Coax Cable w/Connectors – Available in 5',15',25',30',40',60',80',100' Lengths	49-4000-XX (XX = # of Feet)
Bulkhead Extensions – Used to provide an external antenna connection when mounting control unit inside another enclosure	
TNC Male to TNC Bulkhead Cable Assembly - Available in 2', 4', 7' Lengths	49-5004-X-ISO (X = # of Feet)



# DRY CONTACT INPUT WIRING 4-Input Transmitter

### Standard wiring of a dry contact input transmitter

Shorting together the contacts of the respective channel will cause it to transmit. This can be done with any type of manual or automatic switch.

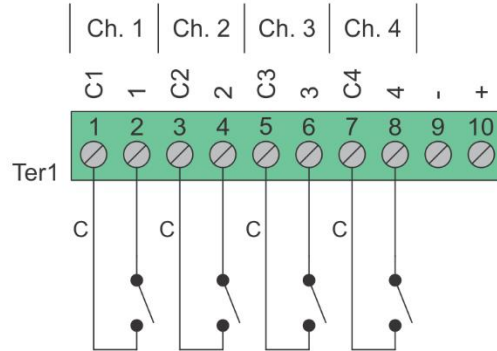

### Standard Wiring for Common Ground Applications

Because each channel shares a common (C) terminal, inputs can be wired as shown to allow for fewer conductors to be run to the transmitter.

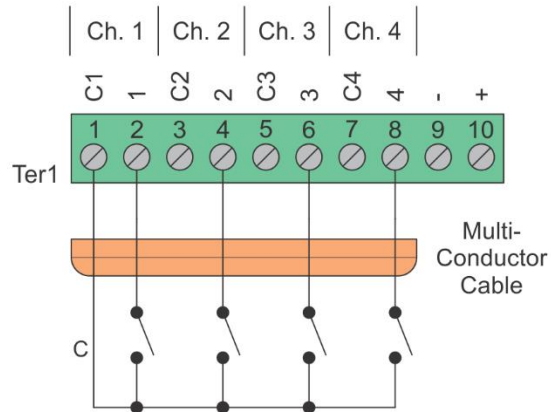

### SPDT Switches

The common (C) terminal of the switch only needs to be connected to one of the channels ground terminal. In this configuration two channels would be transmitting all the time. A switch with a center "off" position would allow transmitting to stop. In this example channels 2 and 4 are transmitting.

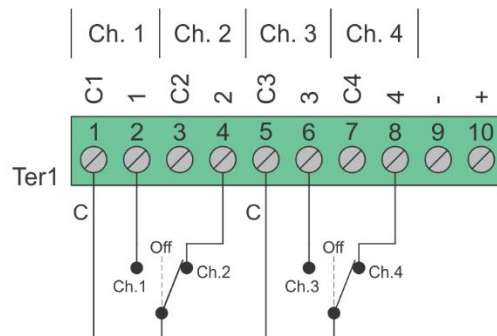

Wiring configurations shown here are examples. The wiring for your application may differ. Call BWI Eagle for assistance or consult an electrician.



# RELAY OUTPUT WIRING 4-Relay Receiver

Receiver outputs are dry relay contacts, like an SPDT switch. When the relay is in a de-energized state, the N/C (normally closed) contact is connected to C (common). When the relay is energized the N/O (normally open) contact is connected to C (common).

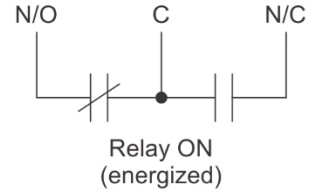
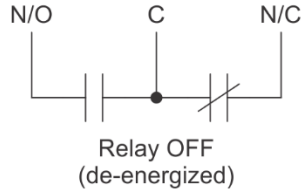

## Normally Open Application with Externally Supplied Voltage

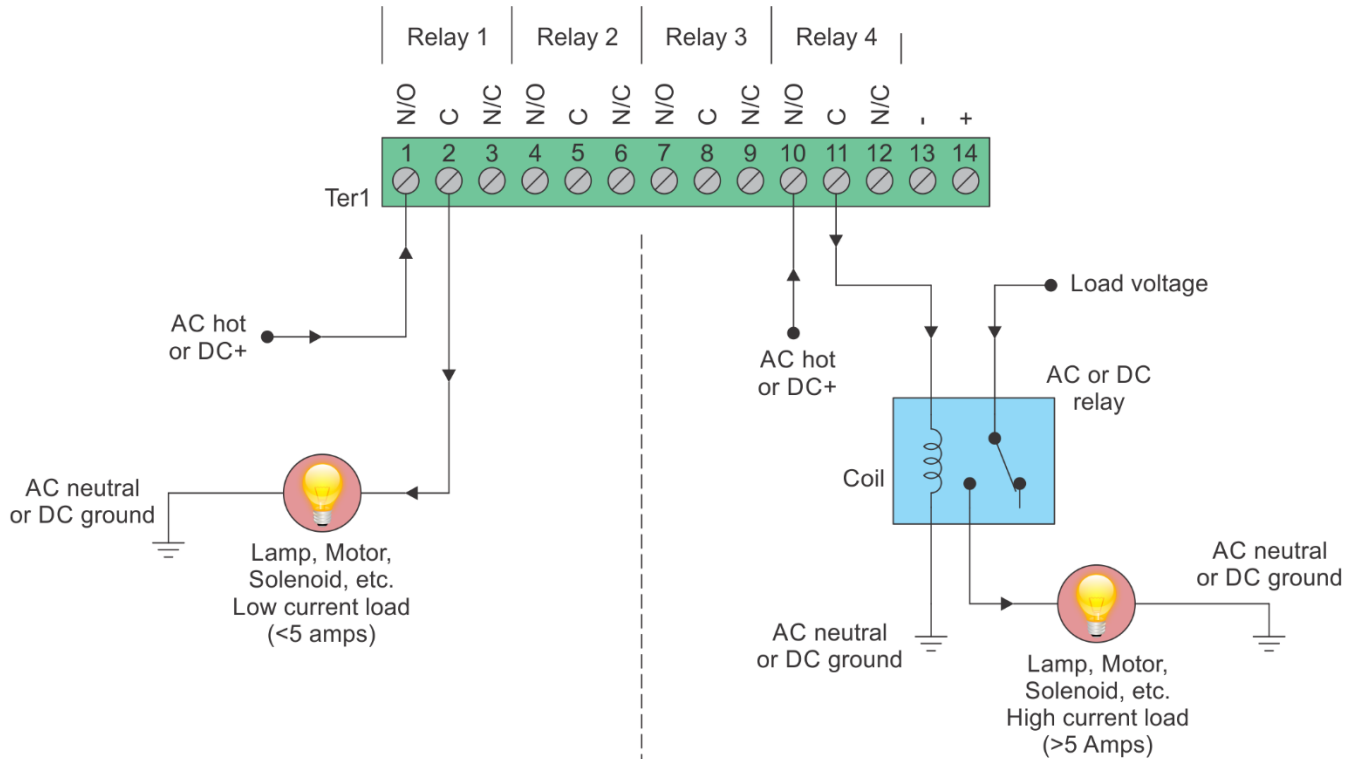

### Internal Relay - Loads Less Than 5 Amps

Loads up to 5 Amps may be wired directly to the internal relays. Wiring to the N/O contact will cause the load to turn on when the relay is energized (the load is on when the relay is on). Wiring to the N/C contact will cause the load to turn on when the relay is de-energized (the load is on when the relay is off). AC or DC voltages can be switched through the relay.

### External Relay - Loads Over 5 Amps

Loads over 5 Amps must use an external high current relay. Diagram shows how to turn on the relay using the lower current internal relay of the receiver. AC or DC voltages can be switched through the relay. Note: A protection diode for DC coils or an MOV for AC coils is recommended to reduce inductive EMI noise.

Wiring configurations shown here are examples. The wiring for your application may differ.  
Call BWI Eagle for assistance or consult an electrician.