



PRODUCT INFORMATION BULLETIN

AIR-EAGLE® SR PLUS 2.4 GHz RF Transmitter MODEL 36-1400-BAT

DESCRIPTION

The AIR-EAGLE SR PLUS TX is an R.F. transmitter capable of sending four independent dry contact input commands to an Air-Eagle SR Receiver from up to 600 feet away. Any number of transmitters and receivers can be combined to create a medium-range remote control system that operates hazardous or hard-to-reach electrical apparatus from safe, convenient locations. This unit has eight user-selectable network frequencies to allow multiple systems to operate simultaneously in the same area without interference.

APPROVALS

United States (FCC)	MCQ-XBEE3
Canada (IC)	1846A-XBEE3
Europe (CE)	ETSI

INSTALLATION

1. Mount the AIR-EAGLE SR PLUS TRANSMITTER in a convenient location.
2. Install wiring to contact input terminal strip (Note – the terminal block header lifts off the base for easy wiring)
3. Attach supplied antenna to connector on right side of unit.
4. Install the 2 AA Lithium batteries that were provided.

TERMINAL STRIP WIRING

Wire as shown based on number of contact inputs									
1	2	3	4	5	6	7	8	9	10
C Input 1	Input 1	C Input 2	Input 2	C Input 3	Input 3	C Input 4	Input 4	Not Used	Not Used

GENERAL OPERATION

A closure on any input transmits its channel command to activate the corresponding relay in the remote receiver. The transmission continues as long as the input is closed and ceases when the input opens.



Dimensions (with mounting plate) 6.3" L x 4.8" W x 2.3" H

CONTROLS & INDICATORS

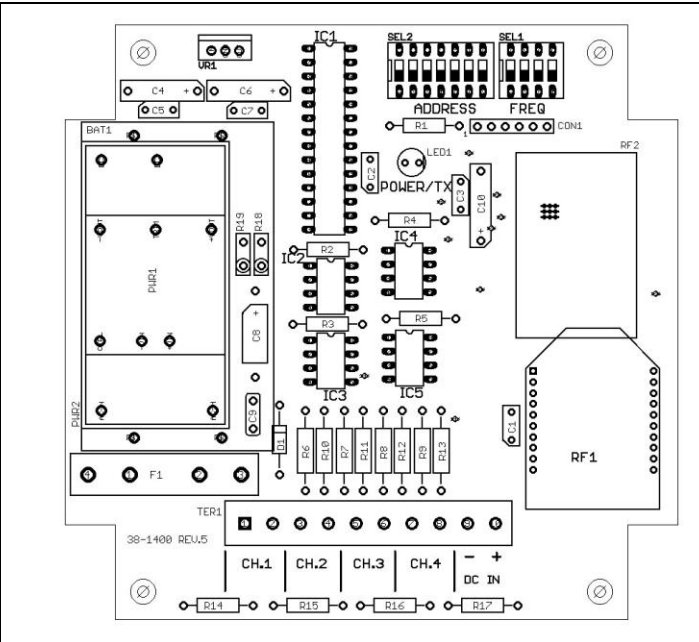

TX LED	Illuminates red while any contact input is closed and unit is transmitting. When this LED blinks briefly following a transmission, the battery needs to be replaced.
Dry Contact Inputs	Transmits individual RF codes to the receiver
SEL1	Dip switch bank for frequency selection
SEL2	Dip switch bank for digital address selection

AIR-EAGLE® SR PLUS

2.4 GHz RF Transmitter

MODEL 36-1400-BAT

FREQUENCY & DIGITAL ADDRESS SET-UP

This transmitter is factory programmed to Frequency "1" and Digital Address "1". These settings can be changed by the user in any combination **but must match the receiver that is set up to communicate with this transmitter.** Note – only change digital address if using with a digitally addressable receiver. Otherwise, the digital address must be kept at the default of Digital Address "1".

- 1) Remove power from unit.
- 2) Remove top cover.
- 3) Select desired network frequency and/or digital address using table below.
- 4) Reattach cover and apply power.
- 5) Programming is now complete.

FREQUENCY SET-UP

SEL1 (SW1-3)

SEL1 (SW1-3)	Network Frequency	SW1	SW2	SW3
	1 (default)	OPEN	OPEN	OPEN
	2	CLOSED	OPEN	OPEN
	3	OPEN	CLOSED	OPEN
	4	CLOSED	CLOSED	OPEN
	5	OPEN	OPEN	CLOSED
	6	CLOSED	OPEN	CLOSED
	7	OPEN	CLOSED	CLOSED
	8	CLOSED	CLOSED	CLOSED

SEL1 (SW4) – Not used on this model

DIGITAL ADDRESS SET-UP

SEL2 (SW1 – 4)

SEL2 (SW1-4)	Digital Address	SW1	SW2	SW3	SW4
	1 (default)	OPEN	OPEN	OPEN	OPEN
	2	CLOSED	OPEN	OPEN	OPEN
	3	OPEN	CLOSED	OPEN	OPEN
	4	CLOSED	CLOSED	OPEN	OPEN
	5	OPEN	OPEN	CLOSED	OPEN
	6	CLOSED	OPEN	CLOSED	OPEN
	7	OPEN	CLOSED	CLOSED	OPEN
	8	CLOSED	CLOSED	CLOSED	OPEN
	9	OPEN	OPEN	OPEN	CLOSED
	10	CLOSED	OPEN	OPEN	CLOSED
	11	OPEN	CLOSED	OPEN	CLOSED
	12	CLOSED	CLOSED	OPEN	CLOSED
	13	OPEN	OPEN	CLOSED	CLOSED
	14	CLOSED	OPEN	CLOSED	CLOSED
	15	OPEN	CLOSED	CLOSED	CLOSED
	16	CLOSED	CLOSED	CLOSED	CLOSED

SEL2 (SW5-7) – Leave in OPEN position!!

SPECIFICATIONS

Power Requirements	3.0 VDC
Battery Type	(2) 1.5V lithium or alkaline each, size AA, to equal 3.0VDC nominal.
Battery Life (Active Usage)	Approximately 3 months
Battery Life (Idle)	Up to 1 Year
Transmit Frequency	2.4GHz Spread Spectrum
Transmitter Inputs	Dry Contact
RF Networks	Eight Independent Frequencies
Digital Addresses	Sixteen
RF Networks	Eight Independent Frequencies
RF Output Power	60 mW
Transmit Range	Up to 600 Feet
<small>Note: Max range figures are estimates, based on free-air terrain with limited sources of interference. Actual range will vary based on transmitting power, orientation of transmitter and receiver, height of transmitting antenna, height of receiving antenna, weather conditions, interference sources in the area, and terrain between receiver and transmitter, including, but not limited to, indoor and outdoor structures such as walls, metal objects, trees, buildings, hills, and mountains</small>	
Antenna Connection	TNC Female
Enclosure	Polycarbonate, IP66 (NEMA 4)
Operating Temperature	-40° F to +140° F

ACCESSORIES

Standard Antenna (Included):	
2.4GHz TNC "Rubber Duck" Antenna	49-1201
Mobile/Base Antennas – Used to help achieve max range in both non line of sight and line of sight applications. - Contact BWI Eagle for recommendations	
2.4GHz Thru-Hole Mount Mobile Antenna	49-2201
2.4GHz Magnet Mount Mobile Antenna	49-2202
2.4GHz Omni Directional Base Antenna	49-3201
2.4GHz Yagi Directional Base Antenna	49-3202
High Quality Coax Cables – Used to connect external high gain antennas to control unit	
Flex Coax Cable w/Connectors – Available in 5',15',25',30',40',60',80',100' Lengths	49-4000-XX (XX = # of Feet)
Bulkhead Extensions – Used to provide an external antenna connection when mounting control unit inside another enclosure	
TNC Male to TNC Bulkhead Cable Assembly - Available in 2', 4', 7' Lengths	49-5004-X-ISO (X = # of Feet)

LIMITED WARRANTY STATEMENT

BWI Eagle Inc. warrants the Air-Eagle Remote Control System, if properly used and installed, will be free from defects in material and workmanship for a period of 1 year after date of purchase. Said warranty to include the repair or replacement of defective equipment. This warranty does not cover damage due to external causes, including accident, problems with electrical power, usage not in accordance with product instructions, misuse, neglect, alteration, repair, improper installation, or improper testing. This limited warranty, and any implied warranties that may exist under state law, apply only to the original purchaser of the equipment, and last only for as long as such purchaser continues to own the equipment. This warranty replaces all other warranties, express or implied including, but not limited to, the implied warranties or merchantability and fitness for a particular purpose. BWI Eagle makes no express warranties beyond those stated here. BWI disclaims without limitation, implied warranties of merchantability and fitness for a particular purpose. Some jurisdictions do not allow the exclusion of implied warranties so this limitation may not apply to you. To obtain warranty service, contact BWI Eagle for a return material authorization. When returning equipment to BWI Eagle, the customer assumes the risk of damage or loss during shipping and is responsible for the shipping costs incurred.



DRY CONTACT INPUT WIRING 4-Input Transmitter

Standard wiring of a dry contact input transmitter

Shorting together the contacts of the respective channel will cause it to transmit. This can be done with any type of manual or automatic switch.

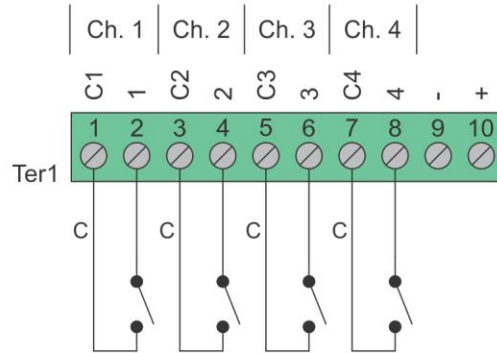

Standard Wiring for Common Ground Applications

Because each channel shares a common (C) terminal, inputs can be wired as shown to allow for fewer conductors to be run to the transmitter.

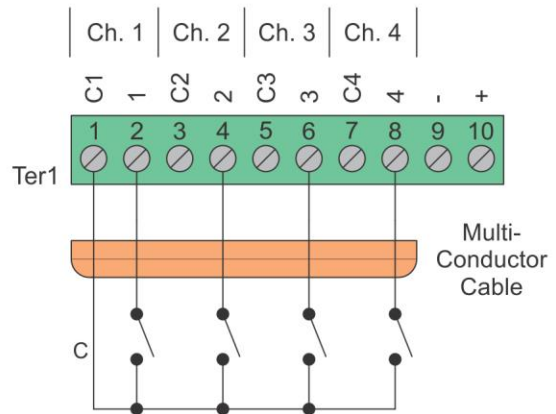

SPDT Switches

The common (C) terminal of the switch only needs to be connected to one of the channels ground terminal. In this configuration two channels would be transmitting all the time. A switch with a center "off" position would allow transmitting to stop. In this example channels 2 and 4 are transmitting.

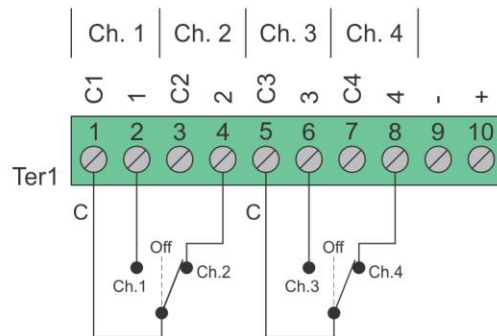

Wiring configurations shown here are examples. The wiring for your application may differ. Call BWI Eagle for assistance or consult an electrician.